

# MITSUBISHI

Positioning Module Type AD71(S1/S2/S7)/A1SD71-S2(S7)

User's Manual

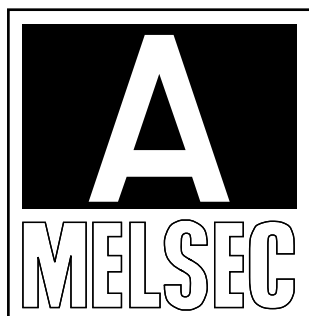
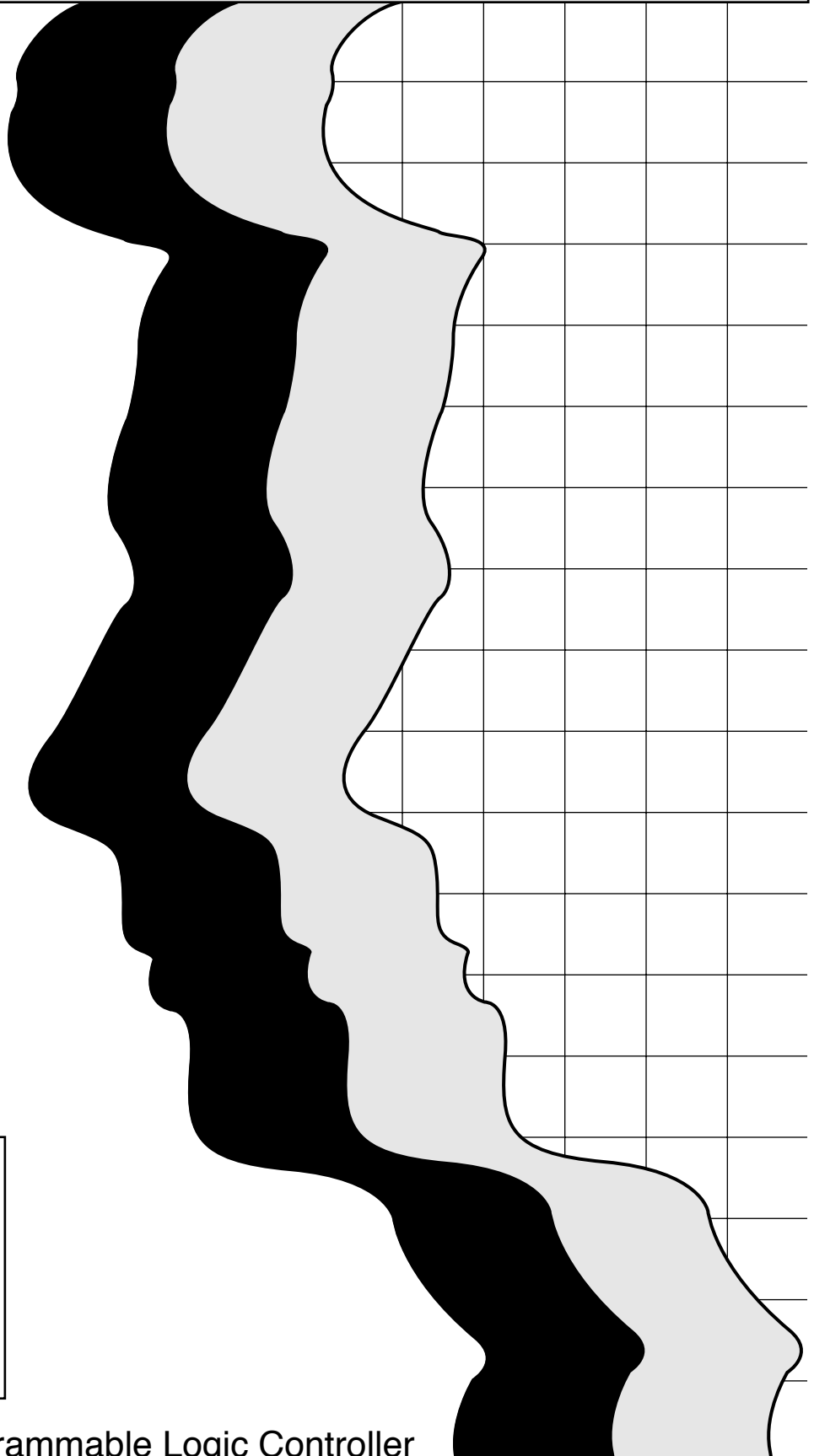

Mitsubishi Programmable Logic Controller



## • SAFETY INSTRUCTIONS •

(Always read these instructions before using this equipment.)

Before using this product, please read this manual and the relevant manuals introduced in this manual carefully and pay full attention to safety to handle the product correctly.

The instructions given in this manual are concerned with this product. For the safety instructions of the programmable logic controller system, please read the CPU module user's manual.

In this manual, the safety instructions are ranked as "DANGER" and "CAUTION".

 <b>DANGER</b>	Indicates that incorrect handling may cause hazardous conditions, resulting in death or severe injury.
 <b>CAUTION</b>	Indicates that incorrect handling may cause hazardous conditions, resulting in medium or slight personal injury or physical damage.

Note that the  CAUTION level may lead to a serious consequence according to the circumstances. Always follow the instructions of both levels because they are important to personal safety.

Please save this manual to make it accessible when required and always forward it to the end user.

### [Design Instructions]

#### **DANGER**

- Provide a safety circuit outside the programmable logic controller so that the entire system will operate safely even when an external power supply error or PLC fault occurs.  
Failure to observe this could lead to accidents for incorrect outputs or malfunctioning.
  - (1) Configure an emergency stop circuit and interlock circuit such as a positioning upper limit/lower limit to prevent mechanical damage outside the PLC.
  - (2) The machine zero point return operation is controlled by the zero point return direction and zero point return speed data. Deceleration starts when the near-point dog turns ON. Thus, if the zero point return direction is incorrectly set, deceleration will not start and the machine will continue to travel. Configure an interlock circuit to prevent mechanical damage outside the PLC.
  - (3) Set the parameters to the positioning system specifications.  
Make sure that the zero point return parameter and positioning data are within the parameter setting values.

## [Design Instructions]

### CAUTION

- Do not bundle or adjacently lay the control wire or communication cable with the main circuit or power wire.  
Separate these by 100mm or more.  
Failure to observe this could lead to malfunctioning caused by noise.

## [Mounting Instructions]

### CAUTION

- Use the PLC within the general specifications environment given in this manual.  
Using the PLC outside the general specification range environment could lead to electric shocks, fires, malfunctioning, product damage or deterioration.
- Always securely insert the module latches at the bottom of the module into the fixing holes on the base unit. (Always screw the AnS Series module onto the base unit with the specified torque.)  
Improper mounting of the module could lead to malfunctioning, faults or dropping.
- Securely connect the drive unit connector and peripheral device connector to the module connectors.  
Improper connection could lead to a connection fault, and to incorrect inputs and outputs.
- When not connecting the drive unit, always install a cover on the connector section.  
Failure to observe this could lead to malfunctioning.

## [Wiring Instructions]

### DANGER

- Always confirm the terminal layout before connecting the wires to the module.
- Make sure that foreign matter such as cutting chips and wire scraps does not enter the module.  
Failure to observe this could lead to fires, faults or malfunctioning.

## [Startup/Maintenance Instructions]

### DANGER

- Always turn all phases of the power supply OFF externally before cleaning or tightening the screws.  
Failure to turn all phases OFF could lead to electric shocks.

## [Startup/Maintenance Instructions]

### CAUTION

- Never disassemble or modify the module.  
Failure to observe this could lead to trouble, malfunctioning, injuries or fires.
- Always turn all phases of the power supply OFF externally before installing or removing the module.  
Failure to turn all phases OFF could lead to module trouble or malfunctioning.
- Before starting test operation, set the parameter speed limit value to the slowest value, and make sure that operation can be stopped immediately if a hazardous state occurs.
- Connect the battery correctly. Do not charge, disassemble, heat, throw into fire, short, or solder it. Incorrectly handling the battery may cause injury or fire due to heat buildup, burst, ignition, etc.

### CAUTION

- Do not drop or impact the battery fitted to the module.  
To do so may damage the battery, causing the battery liquid to leak inside the battery. Dispose of the dropped or impacted battery without using it.
- Always make sure to touch the grounded metal to discharge the electricity charged in the body, etc., before touching the module.  
Failure to do so may cause a failure or malfunctions of the module.

## [Precautions for use]

### CAUTION

- Note that when the reference axis speed is designated for interpolation operation, the speed of the partner axis (2nd axis) may be larger than the set speed (larger than the speed limit value).
- When no parameters have been set or any one parameter is erroneous (outside the setting range), all parameter data are controlled as default values.

## [Disposal Instructions]

### CAUTION

- When disposing of the product, handle it as industrial waste.

## [Transportation Instructions]

### CAUTION

- When a lithium-containing battery is to be transported, it must be handled in conformance to the transportation restrictions.

## REVISIONS

\* The manual number is given on the bottom left of the back cover.

Print Date	*Manual Number	Revision
Mar., 1995	IB (NA) 66563-A	First edition
Oct., 2003	IB (NA) 66563-B	<p data-bbox="730 439 842 472"><b>Addition</b></p> <p data-bbox="730 479 1350 573">Conformation to the EMC Directive and Low Voltage Instruction, Section 5.4.4, Appendix 3.3, 6, 6.1, 6.2, WARRANTY</p> <p data-bbox="730 636 927 669"><b>Partial Addition</b></p> <p data-bbox="730 676 1398 797">SAFETY PRECAUTIONS, CONTENTS, Manuals, Chapter 2, Section 2.1, 2.2.1, Chapter 3, Section 3.1, 3.5.1, 3.5.3, 3.5.4, 3.6, 3.6.1, 3.6.3, 3.8.2, 3.9, 4.2, 6.3.3, 6.3.6, 6.3.10, 6.3.11, 6.4, 8.1.1, 8.1.6, 9.2</p> <p data-bbox="730 860 954 893"><b>Partial Correction</b></p> <p data-bbox="730 900 1390 1084">SAFETY PRECAUTIONS, CONTENTS, Chapter 1, Section 2.1, 2.3, 3.3, 3.4.1 3.4.3, 3.5, 3.5.1, 3.5.2, 3.5.3, 3.5.4, 3.6.1, 3.6.2, 3.7, 3.8.1, 3.8.2, 6.1.2, 6.3.2, 6.3.3, 6.3.6, 6.3.7, 6.3.8, 6.3.9, 6.4.2, 6.4.3, 8.1, 8.1.1, 8.1.2, Appendix 1.2, 2.2, 2.3, 3.2, 3.4, 3.5, 3.6, 3.7, 3.8, 3.9, 3.10, 3.11, 3.12</p> <p data-bbox="730 1115 858 1149"><b>Deletion</b></p> <p data-bbox="730 1155 887 1189">Section 8.1.2</p>

## **INTRODUCTION**

Thank you for choosing the Mitsubishi MELSEC-A Series of General Purpose Programmable Controllers. Please read this manual carefully so that the equipment is used to its optimum. A copy of this manual should be forwarded to the end User.

# CONTENTS

<b>1. INTRODUCTION</b> .....	<b>1-1-1-1</b>
<b>2. SYSTEM CONFIGURATION</b> .....	<b>2-1-2-5</b>
2.1 AD71Overall Configuration .....	2-1
2.2 Applicable Systems .....	2-3
2.2.1 Applicable CPUs .....	2-3
2.2.2 Precautions on system configuration .....	2-4
2.3 Programming Equipment .....	2-5
<b>3. SPECIFICATIONS</b> .....	<b>3-1-3-84</b>
3.1 General Specifications .....	3-1
3.2 Performance Specifications and Functions .....	3-2
3.3 Function List .....	3-3
3.4 General Description of Positioning System Operations .....	3-6
3.4.1 Positioning system using an AD71 .....	3-6
3.4.2 Signal communications between an AD71 and each unit .....	3-9
3.4.3 AD71 operation description .....	3-10
3.5 Types and Functions of Setting Data .....	3-12
3.5.1 Parameters .....	3-13
3.5.2 Zero return data .....	3-24
3.5.3 Positioning data .....	3-29
3.5.4 Positioning mode of AD71S2/A1SD71-S2 .....	3-38
3.6 Buffer Memory .....	3-46
3.6.1 Positioning start data .....	3-48
3.6.2 OS data area (Addresses 512 to 767) .....	3-63
3.6.3 Positioning data area (X axis :address 3872 to 5871, Y axis :address 5872 to 7871) .....	3-64
3.6.4 Parameter area (X axis: addresses 7872 - 7887; Y axis: addresses 7892 -7907) .....	3-66
3.6.5 Zero return data area (X axis :address 7912 to 7918, Y axis :address 7922 to 7928) .....	3-67
3.7 I/O Signals From/To PC CPU .....	3-68
3.8 I/O Interface with External Equipment .....	3-75
3.8.1 AD71 electrical specifications .....	3-75
3.8.2 Input/output interface specifications of the AD71 and an external device ...	3-77
3.9 Battery Specifications .....	3-82
<b>4. HANDLING</b> .....	<b>4-1-4-3</b>
4.1 Handling Instructions .....	4-1
4.2 Nomenclature .....	4-2
4.3 Battery Connection .....	4-3
<b>5. LOADING AND INSTALLATION</b> .....	<b>5-1-5-9</b>
5.1 Installation Environment .....	5-1

5.2	Unit Wiring Precautions .....	5-1
5.3	Mounting and Removing the Module .....	5-2
5.3.1	Mounting and removing the AD71(S1/S2/S7) .....	5-2
5.3.2	Mounting and removing the A1SD71-S2(S7) .....	5-4
5.4	Wiring .....	5-6
5.4.1	Wiring precautions .....	5-6
5.4.2	Connecting external wiring .....	5-9
5.4.3	Connecting electric wiring .....	5-9
5.4.4	Compliance with EMC and low-voltage directives .....	5-10
<b>6.</b>	<b>PROGRAMMING .....</b>	<b>6-1-6-62</b>
6.1	Program Creation .....	6-1
6.1.1	Program composition .....	6-1
6.1.2	Precautions when creating programs .....	6-3
6.2	Operations Using a Peripheral Device .....	6-6
6.3	Programming .....	6-7
6.3.1	Data read and write precautions .....	6-7
6.3.2	Data communication with PC program .....	6-8
6.3.3	Positioning start program .....	6-16
6.3.4	Speed/positioning control switching program (for AD71S2 or A1SD71-S2) ..	6-24
6.3.5	Speed control program (for AD71S2 or A1SD71-S2) .....	6-27
6.3.6	Jog operation program .....	6-29
6.3.7	Manual pulse generator operation program (for AD71(S1/S7) or A1SD71-S7) .....	6-32
6.3.8	Positioning address teaching program .....	6-36
6.3.9	Zero return .....	6-43
6.3.10	Present value change .....	6-45
6.3.11	Positioning stop .....	6-47
6.4	ACPU Remote I/O Station Programming .....	6-53
6.4.1	Notes on programming .....	6-53
6.4.2	Reading and writing data .....	6-55
6.4.3	Program example .....	6-58
<b>7.</b>	<b>TRIAL OPERATION AND ADJUSTMENT .....</b>	<b>7-1-7-3</b>
7.1	General Check List .....	7-1
7.2	Tests and Adjustments Procedure .....	7-2
7.2.1	Sequence check .....	7-2
7.2.2	Positioning operation check .....	7-3
<b>8.</b>	<b>TROUBLESHOOTING .....</b>	<b>8-1-8-17</b>
8.1	Errors Detected by AD71 .....	8-1
8.1.1	Data range errors .....	8-2
8.1.2	AD71 "HOLD" errors .....	8-5
8.1.3	Buffer memory write errors .....	8-5
8.1.4	AD71 start and operation errors .....	8-6
8.1.5	AD71 positioning start errors during BUSY .....	8-7



8.1.6	Other errors .....	8-7
8.2	Troubleshooting .....	8-8
8.2.1	General troubleshooting .....	8-8
8.2.2	Drive inoperative .....	8-9
8.2.3	Incorrect positioning .....	8-11
8.2.4	Positioning speed wrong .....	8-13
8.2.5	Corrupted positioning data .....	8-14
8.2.6	Unrequested stop .....	8-15
8.2.7	Zero return fault .....	8-16
<b>9.</b>	<b>MAINTENANCE .....</b>	<b>9-1-9-4</b>
9.1	Unit Storage .....	9-1
9.2	Battery Change .....	9-2
9.2.1	Battery change frequency .....	9-2
9.2.2	Battery replacement procedure .....	9-3
	<b>APPENDICES .....</b>	<b>APP-1-APP-34</b>
	<b>APPENDIX 1 FORMAT SHEETS .....</b>	<b>APP-1</b>
1.1	MELSEC-A Positioning unit .....	APP-1
1.2	Format Sheets .....	APP-2
1.3	Positioning Data (Data No. to ) .....	APP-4
1.4	M Code Comments .....	APP-5
	<b>APPENDIX 2 SIGNAL TIMING FROM THE AD71 .....</b>	<b>APP-6</b>
2.1	Output Signal Timing .....	APP-6
2.2	Start Delay Time .....	APP-7
2.3	AD71 Processing Times .....	APP-9
	<b>APPENDIX 3 CONNECTION WITH SERVO MOTORS .....</b>	<b>APP-11</b>
3.1	Connection with MELDAS-S1 .....	APP-11
3.2	Connection with Mitsubishi MELSERVO-H .....	APP-12
3.3	Connection with Mitsubishi MELSERVO-J .....	APP-13
3.4	Connection with Mitsubishi MELSERVO-SA .....	APP-14
3.5	Connection with Mitsubishi MELSERVO-SA-KL .....	APP-15
3.6	Connection with Mitsubishi MELSERVO-SC .....	APP-16
3.7	Connection with Mitsubishi MELSERVO-VA .....	APP-17
3.8	Connection with Oriental's stepping motor .....	APP-18
3.9	Connection with Oriental's AC servo motor .....	APP-19
3.10	Connection with Toei Electric's BS Servo Amplifier .....	APP-20
3.11	Connection with Nikki Denso's AC SERVO CONTROLLER .....	APP-21
3.12	Connection with Yasukawa Electric's PACK-10C .....	APP-22
	<b>APPENDIX 4 OUTSIDE DIMENSIONS .....</b>	<b>APP-23</b>
	<b>APPENDIX 5 POSITIONING DATA NUMBER</b>	
	<b>    AND BUFFER MEMORY ADDRESS CONVERSION TABLE .....</b>	<b>APP-26</b>
	<b>APPENDIX 6 Transportation Precautions .....</b>	<b>APP-34</b>
6.1	Controlled .....	APP-34
6.2	Transport guidelines .....	APP-34

### Conformation to the EMC Directive and Low Voltage Instruction

For details on making Mitsubishi PLC conform to the EMC directive and low voltage instruction when installing it in your product, please see Chapter 3, "EMC Directive and Low Voltage Instruction" of the User's Manual (Hardware) of the PLC CPU to use.

The CE logo is printed on the rating plate on the main body of the PLC that conforms to the EMC directive and low voltage instruction.

Refer to Section 5.5.4 to make this product conform to the EMC directive and low voltage instruction.

## About Manuals

The following manuals are related to this product.

### **Related Manuals**

Manual Name	Manual No. (Model Name Code)
<b>Teaching unit for positioning module type AD71TU operating Manual</b> This manual explains the system configuration, performance specifications, handling, functions, parameter/zero return data/positioning data write/read operation, monitor operation, test operation, etc. (Packed with the AD71TU teaching unit)	IB-66067 (13J706)
<b>Positioning module type AD71 (SW0-AD71PE) operating Manual</b> This manual explains the system configuration, functions, system startup procedure, function operation procedures, and error messages of SW0-AD71PE. (Packed with SW0-AD71PE)	IB-66099 (13J707)
<b>Positioning module type AD71 (SW0IX-AD71PE) operating Manual</b> This manual explains the system configuration, functions, system startup procedure, function operation procedures, and error messages of SW0IX-AD71PE. (Packed with SW0IX-AD71PE)	IB-66508 (13JE75)

## 1. INTRODUCTION

This manual describes the specifications, handling and programming operation of the following types of positioning modules:

- AD71(S1/S2/S7) type positioning module
- A1SD71-S2(S7) type positioning module

These modules are hereinafter called the "AD71" unless it is necessary to distinguish between them.

The AD71 operates with a MELSEC-A series PC CPU. For details of combinations of the AD71 and PC CPUs, refer to 2.2.1.

In this manual, the positioning software packages and peripheral devices are referred to by the following abbreviations:

- SW0-AD71PE type positioning module software package
  - SW0IX-AD71PE type positioning module software package
  - A6GPPE/A6PHPE
  - AD71TU type teaching unit
- ⇒ "A6GPP"  
⇒ "AD71TU"
- } "AD71P"  
} The A6GPP booted up with AD71P and the AD71TU are generically called "peripheral devices".

### POINT

The I/O allocation numbers of the AD71 identified from the PC CPU refer to the numbers when the AD71 is loaded in the following slot of the base unit:

(1) AD71/AD71S1/AD71S2/AD71S7

The numbers are assigned on the assumption that the AD71 is loaded in slot 0 of the main base unit.

(2) A1SD71-S2/A1SD71-S7

The A1SD71-S2 and the A1SD71-S7 occupy 48 I/O points in two slots.

Allocate the following number of I/O points to each slot by using the I/O allocation function of the GPP functions.

[ First half slot ..... Vacant slot, 16 points  
Latter half slot ..... For special function unit, 32 points ]

The 16 points reserved for the first slot can be saved by specifying them as "vacant slot, 0 point".

In this manual, it is assumed that the A1SD71-S2/A1SD71-S7 is loaded in slot 0 and 1 of the main base unit and that "vacant slot, 0 point" is set for the first half slot in I/O allocation using the GPP function.

Some functions differ according to the positioning module. This manual refers to these differences in 1.2. Confirm the functions of the module to be used.

### 2. SYSTEM CONFIGURATION

This chapter explains the system configuration where the AD71 and PLC CPU can be combined.

#### 2.1 AD71 Overall Configuration

The following shows the arrangement of the AD71 and peripheral devices.

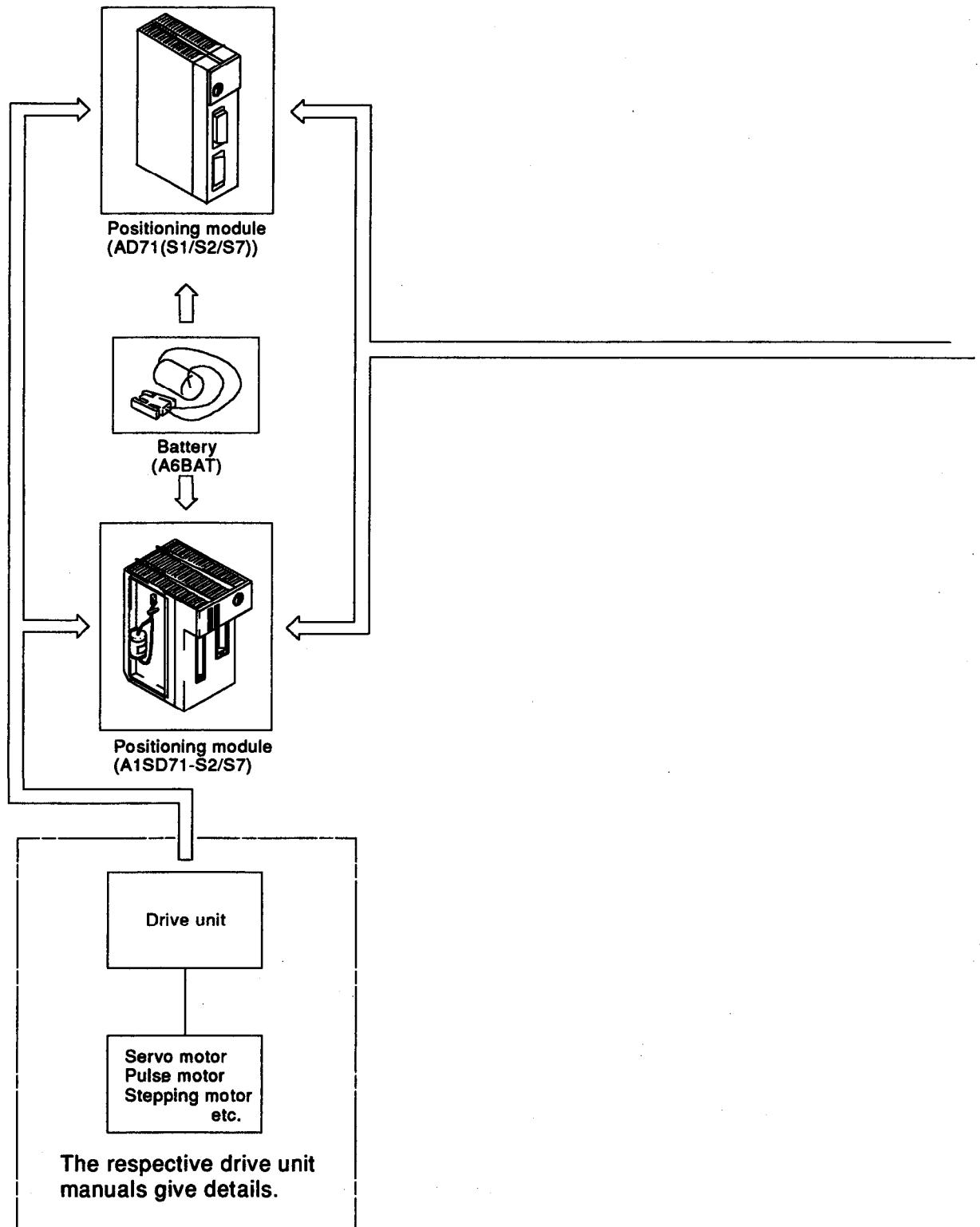

**Fig. 2.1 Overall Configuration**

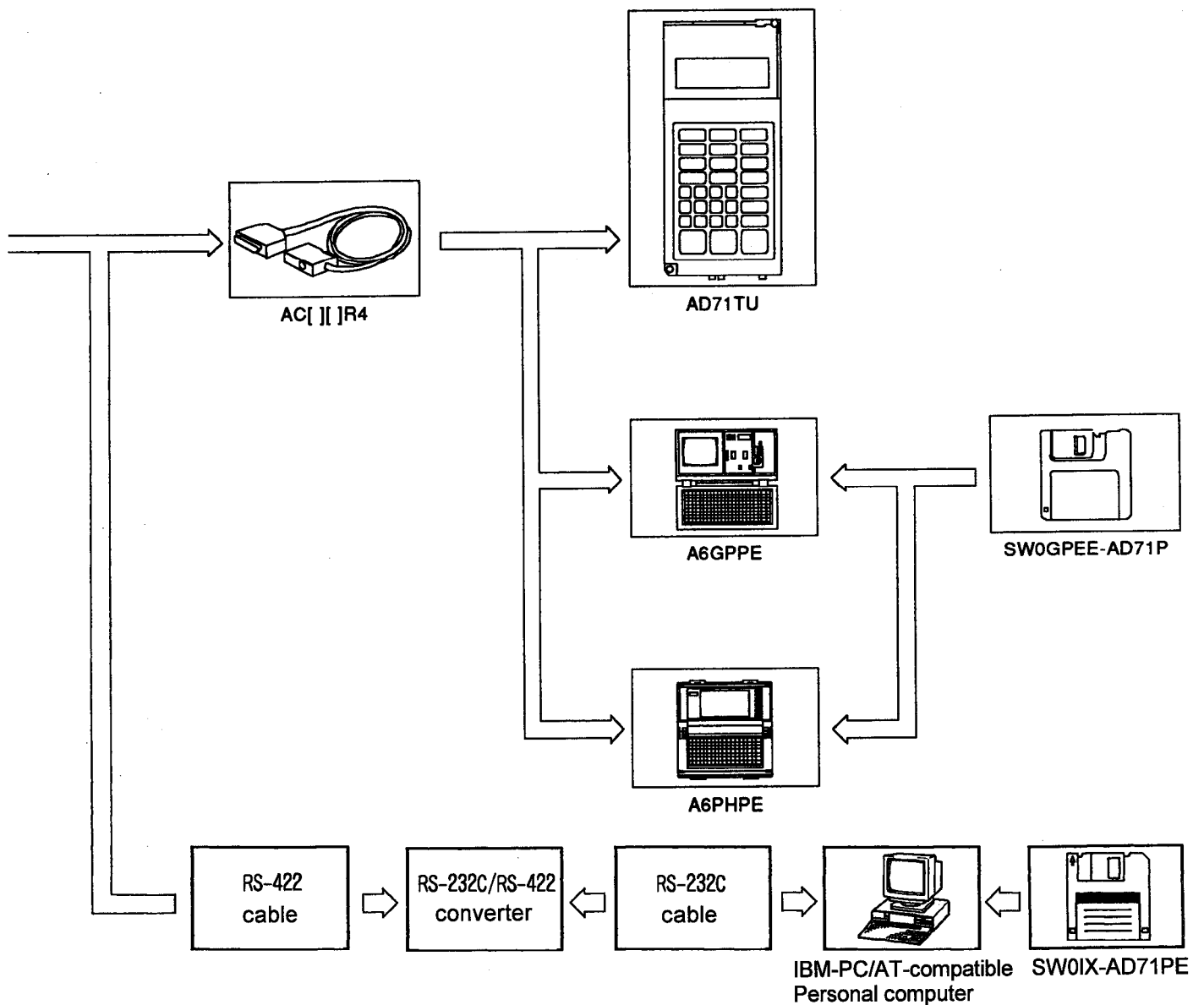

**POINT**  
 For the applicable printer, CRT, etc. for each peripheral device, refer to the GPP Function Software Package Operating Manual for the module.

### 2.2 Applicable Systems

This section indicates the applicable CPUs and gives cautions on configuring a system.

#### 2.2.1 Applicable CPUs

Listed below are the CPUs with which each type of positioning module is compatible.

##### (1) AD71(S1/S2/S7)

The AD71(S1/S2/S7) type positioning module is compatible with the following CPUs (including those equipped with a link function).

• A0J2(H)CPU	• A3MCP	• Q2ACPU	• A1S(H)CPU
• A1CPU	• A3HCP	• Q3ACPU	• A1SJ(H)CPU
• A2CPU(S1)	• A2ACPU(S1)	• Q4ACPU	• A2S(H)CPU
• A3CPU	• A3ACPU	• A73CPU(S3)	• A2ASCPU(S1)
• A1NCP	• A2UCPU(S1)	• A373CPU	• A2USHCPU(S1)
• A2NCP(S1)	• A3UCPU	• A81CPU	• A52GCP(T21B)
• A3NCP	• A4UCPU		• Q2AS(H)CPU

##### (2) A1SD71-S2(S7)

The A1SD71-S2(S7) type positioning module is compatible with the following CPUs.

• A1S(H)CPU	• A2S(H)CPU	• A52GCP(T21B)
• A1SJ(H)CPU	• A2ASCPU(S1)	• Q2AS(H)CPU
	• A2USHCPU(S1)	

### 2.2.2 Precautions on system configuration

Each type of positioning module can be loaded in any slot of the main base unit or an extension base unit. However, note the following points.

- (1) Since the positioning module has a large 5 VDC consumption, do not use it with any extension base unit (A5[ ]B, A1S5[ ]B) that does not have a power supply module if it can be avoided.

If it cannot be avoided, consider the power supply capacity, voltage drop, and other factors, when loading the module in such an extension base unit.

- (2) The module can be mounted in any master, local or remote I/O station in a data link system.
- (3) To load the positioning module in a CPU or base unit, follow the instructions in the CPU User's Manual.

#### POINTS

- (1) The A0J2P25/R25 (remote I/O station) cannot be used with any positioning module installed on it.
- (2) The positioning module cannot be loaded in the main base unit of the A73CPU/A373CPU.  
The positioning module cannot start operation simultaneously with a PCPU control axis of an A73CPU/A373CPU, or interpolate with it.
- (3) The positioning module cannot be loaded in the last slot of the 7th extension stage of an A3CPU.



## 2. SYSTEM CONFIGURATION

MELSEC-A

### 2.3 Programming Equipment

The following table indicates the equipment available for programming the AD71.

Unit Division	Type	Remarks												
Software package	SW0GP-AD71P	A6GPPE/A6PHPE software package												
	SW0IX-AD71PE	IBM PC/AT-compatible personal computer software package												
Intelligent GPP	A6GPPE-SET	<ul style="list-style-type: none"> <li>Consists of the following:</li> </ul> <table border="1"> <thead> <tr> <th>Type</th> <th>Remarks</th> </tr> </thead> <tbody> <tr> <td>A6GPPE</td> <td> <ul style="list-style-type: none"> <li>Programming unit with CRT</li> <li>Equipped with ROM writer, FDD and printer interface functions.</li> </ul> </td> </tr> <tr> <td>SW[ ]GP-GPPA</td> <td>A series system disk</td> </tr> <tr> <td>SW[ ]GP-GPPK</td> <td>K series system disk</td> </tr> <tr> <td>SW0-GPPU</td> <td>User disk (3.5 inch, formatted)</td> </tr> <tr> <td>AC30R4</td> <td>Cable for connecting A1SD71 and A6GPPE.</td> </tr> </tbody> </table>	Type	Remarks	A6GPPE	<ul style="list-style-type: none"> <li>Programming unit with CRT</li> <li>Equipped with ROM writer, FDD and printer interface functions.</li> </ul>	SW[ ]GP-GPPA	A series system disk	SW[ ]GP-GPPK	K series system disk	SW0-GPPU	User disk (3.5 inch, formatted)	AC30R4	Cable for connecting A1SD71 and A6GPPE.
		Type	Remarks											
		A6GPPE	<ul style="list-style-type: none"> <li>Programming unit with CRT</li> <li>Equipped with ROM writer, FDD and printer interface functions.</li> </ul>											
		SW[ ]GP-GPPA	A series system disk											
		SW[ ]GP-GPPK	K series system disk											
		SW0-GPPU	User disk (3.5 inch, formatted)											
		AC30R4	Cable for connecting A1SD71 and A6GPPE.											
Plasma handy programmer	A6PHPE-SET	<ul style="list-style-type: none"> <li>Consists of the following:</li> </ul> <table border="1"> <thead> <tr> <th>Type</th> <th>Remarks</th> </tr> </thead> <tbody> <tr> <td>A6PHPE</td> <td> <ul style="list-style-type: none"> <li>Programming unit with plasma display</li> <li>Equipped with FDD, printer interface and memory cassette functions.</li> </ul> </td> </tr> <tr> <td>SW[ ]GP-GPPA</td> <td>A series system disk</td> </tr> <tr> <td>SW[ ]GP-GPPK</td> <td>K series system disk</td> </tr> <tr> <td>SW0-GPPU</td> <td>User disk (3.5 inch, formatted)</td> </tr> <tr> <td>AC30R4</td> <td>Cable for connecting A1SD71 and A6PHPE. 3 m (9.84 ft) length.</td> </tr> </tbody> </table>	Type	Remarks	A6PHPE	<ul style="list-style-type: none"> <li>Programming unit with plasma display</li> <li>Equipped with FDD, printer interface and memory cassette functions.</li> </ul>	SW[ ]GP-GPPA	A series system disk	SW[ ]GP-GPPK	K series system disk	SW0-GPPU	User disk (3.5 inch, formatted)	AC30R4	Cable for connecting A1SD71 and A6PHPE. 3 m (9.84 ft) length.
		Type	Remarks											
		A6PHPE	<ul style="list-style-type: none"> <li>Programming unit with plasma display</li> <li>Equipped with FDD, printer interface and memory cassette functions.</li> </ul>											
		SW[ ]GP-GPPA	A series system disk											
		SW[ ]GP-GPPK	K series system disk											
		SW0-GPPU	User disk (3.5 inch, formatted)											
		AC30R4	Cable for connecting A1SD71 and A6PHPE. 3 m (9.84 ft) length.											
User disk	SW0-GPPU	Floppy disk for storing user programs (3.5 inch, formatted)												
RS-422 cable	AC30R4	Cable for connecting CPU and A6GPPE. 3 m (9.84 ft) length.												
	AC300R4	Cable for connecting CPU and A6GPPE. 30 m (98.4 ft) length.												
Composite video cable	AC10MD	Cable for connecting GPP screen monitor display. 1 m (3.28 ft) length.												
Cleaning disk	SW0-FDC	Floppy disk for cleaning floppy disk drive.												
Printer	A7NPR-S1	For print out of program ladder diagrams and lists.												
RS-232C cable	AC30R2	Cable for connecting A6GPPE and printer, K6PR-K, A7NPR-S1, general-purpose printer with RS-232C interface). 3 m (9.84 ft) length.												
Printer paper	K6PR-Y	Paper for K6PR-K printer. 9 inch. Available in units of 2000 pcs.												
K6PR ink ribbon	K6PR-R	Replacement ink ribbon for K6PR-K.												
Teaching unit	AD71TU	AD71(S1)/AD72/A1SD71 teach box.												
Manual pulse generator	(OSM-01-2(C))	(Manufactured by Nemicon) <ul style="list-style-type: none"> <li>Prepare beforehand.</li> <li>The generator requires a 12 VDC external power supply.</li> <li>Refer to the outline drawing shown in APPENDIX 4 (3).</li> </ul>												

### 3. SPECIFICATIONS

This chapter explains the specifications, functions, setting data and I/O interfaces of the AD71.

#### 3.1 General Specifications

Table 3.1 shows the general specifications of the AD71.

**Table 3.1 General Specifications**

Item	Specifications				
Operating ambient temperature	0 to 55 °C				
Storage ambient temperature	-20 to 75 °C				
Operating ambient humidity	10 to 90 %RH, non-condensing				
Storage ambient humidity	10 to 90 %RH, non-condensing				
Vibration resistance	Conforms to *JISC0911	Frequency	Acceleration	Amplitude	Sweep Count
		10 to 55 Hz	-	0.075 mm (0.003 inch)	10 times **(1 octave/minute)
		55 to 150 Hz	9.8 m/s <sup>2</sup> (1 g)	-	
Shock resistance	Conforms to *JIS C 0912 (98 m/s <sup>2</sup> (10 g) × 3 times in 3 directions)				
Noise durability	By noise simulator of 1500 Vpp noise voltage, 1 μs noise width and 25 to 60 Hz noise frequency				
Dielectric withstand voltage	500 VAC for 1 minute across DC external terminals and ground 1500 VDC for 1 minute across AC external terminals and ground				
Insulation resistance	5 MΩ or larger by 500 VDC insulation resistance tester across AC external terminals and ground				
Grounding	Class 3 grounding : If appropriate grounding is not available, connect the grounding wire to the electric panel.				
Operating ambience	Free of corrosive gases. Dust should be minimal.				
Cooling method	Self-cooling				

\*JIS :Japanese Industrial Standard

#### POINT

When using the A1SD71-S2(S7) with an A1SCPU, A1SJCPU, A2SCPU or A2ASCPU(S1), ground the module using class 3 grounding. If this is not possible, connect the grounding wire to the electric panel.

### 3. SPECIFICATIONS

MELSEC-A

#### 3.2 Performance Specifications and Functions

**Table 3.2 Performance Specifications**

Item		AD71(S1)	AD71S2	AD71S7	A1SD71-S2	A1SD71-S7
Number of I/O points		32 points			48 points* (number of occupied slots : 2)	
Number of control axes		2 (simultaneous or independent)				
Interpolation		Linear interpolation (for simultaneous 2 axes)				
Positioning data	Capacity	400 points per axis				
	Setting method	Input from peripheral device or sequence program				
RAM memory backup		15 minutes without battery (25 °C) Lithium battery guarantees power failure backup for a total of 300 days. Battery guaranteed for five years.				
Positioning	Modes	Positioning control mode	<ul style="list-style-type: none"> <li>Positioning control mode</li> <li>Speed/positioning control switching mode</li> <li>Speed control mode Select using parameters. (Same mode is applied to the X and Y axes.)</li> </ul>	Positioning control mode	<ul style="list-style-type: none"> <li>Positioning control mode</li> <li>Speed/positioning control switching mode</li> <li>Speed control mode Select using parameters. (Same mode is applied to the X and Y axes.)</li> </ul>	Positioning control mode
	Method	Positioning control mode : Absolute or incremental method is selectable at each axis (AD71S2, A1SD71-S2 speed/positioning control switching mode: Incremental method current address is switched to 0 when starting.)				
	Positioning units	1 to 16,252,928 (PLS) Max. 162 (m) (command unit: 0.1 to 10 μm/PLS) Max. 16200 (inch) (command unit: 1 × 10 <sup>-5</sup> to 0.001 inch/PLS) Max. 16200 (degree) (command unit: 1 × 10 <sup>-5</sup> to 0.001 degree/PLS)				
	Positioning speed	10 to 200000 (PLS/sec) (command unit: 10 PLS/sec) 10 to 120000 (mm/min) (command unit: 10 mm/min) 1 to 12000 (inch/min) (command unit: 1 inch/min) 1 to 12000 (degree/min) (command unit: 1 degree/min)				
	Acceleration and deceleration	Automatic trapezoidal acceleration and deceleration				
	Acceleration and deceleration times	64 to 4999 (msec)	64 to 50000 (msec)	64 to 4999 (msec)	64 to 50000 (msec)	64 to 4999 (msec)
Internal current consumption	5 VDC, 1.5 A			5 VDC, 0.8A		
External supply voltage, current	4.75 to 26.4 V, Max. 50 mA					
Size mm (inch)	250(H) × 37.5(W) × 121(D) (9.84 × 1.48 × 4.76)			130(H) × 69.5(W) × 93.6(D) (5.12 × 2.74 × 3.69)		
Weight kg (lb)	0.63(1.93)			0.38(0.84)		

\* I/O allocation for the 2 slots are as follows:  
 First half slot .....Empty slot: 16 points  
 Second half slot ...Special-function module: 32 points

3.3 Function List

Table 3.3 List of AD71 Series Functions

Functions		Description	Positioning Module			
			AD71	AD71S1	AD71S2 A1SD71-S2	AD71S7 A1SD71-S7
Inching operation		The drive for the given axis is advanced by a predefined number of pulses each time a manual pulse is received. The manual pulse is provided by a manual pulse generator.	○	○	—	○
JOG operation function		JOG operations can be done when a JOG operation command from the PC CPU (or peripheral device) is turned ON. The system will travel beyond the stroke limit and stop if the JOG operation instruction remains on for a long time.	○	○	○	○
Zero return		Returns by a zero return start command from the PC CPU (or peripheral device). The current value is corrected to the zero address after zero return is completed.	○	○	○	○
Positioning	Positioning control modes	One-time positioning	○	○	○	○
		n-times positioning	○	○	○	○
		Positioning accompanied by a change in speed (pattern change)	○	○	○	○
	Speed/positioning control switching mode		—	—	○	—
	Speed control mode		—	—	○	—
Backlash compensation		By setting the mechanical drive backlash compensation amount, sufficient pulses for the set compensation amount will be additionally generated each time the travel direction changes during positioning in the positioning control mode, or when, in the speed/positioning control switching mode, the travel direction at operation resumption is different from that at initial start-up.	○	○	○	○
Error compensation		This function compensates an error ascribed to the difference between the set value and the actual feed amount. Errors are compensated during manual pulse generator operation, JOG operation or positioning. For details on setting the error compensation parameter, refer to 3.5.1(9).	○	○	○	○
M code ON/OFF timing		M codes are user-assigned codes (1 to 255) to control auxiliary functions (e.g. clamping, drill rotation, etc.) after positioning control. M codes are effective in two timing modes: in the WITH mode, an "M code ON" signal is issued almost concurrently with the start of positioning; in the AFTER mode, that signal is generated after positioning is completed.	○	○	○	○

- (1) Functions available with the AD71(S1/S7) and the A1SD71-S7
  - (a) While the pulse output speed during pulse generator operation is constant with the AD71(S1), it can be changed in 10 pulses/s units to any required value with the AD71S7 or A1SD71-S7.

	AD71(S1)	AD71S7, A1SD71-S7
Pulse output speed during manual pulse operation	Fixed at 20,000 pulses/s	10 to 20,000 pulses/s (adjustable in 10 pulses/s units)

### 3. SPECIFICATIONS

- (2) Functions available with the AD71S2 and the A1SD71-S2
  - (a) A sequence program is used to select one of the three positioning methods with the AD71S2 or A1SD71-S2.
  - (b) Even if the system stops during positioning after the mode is switched from speed to positioning control, a restart command will be issued to enable the system to complete positioning.

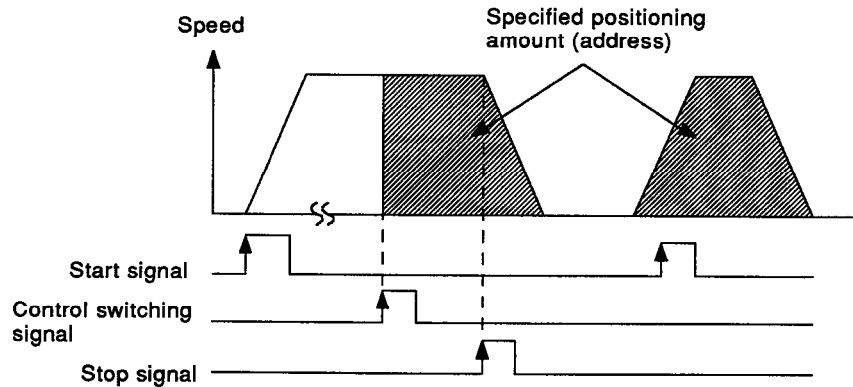

- (3) Common functions
  - (a) If positioning is done using a sequence program in the positioning control mode or speed/positioning control switching modes, a PC CPU can output the set M code from an AD71 when positioning starts or after positioning is completed. (Peripheral devices do not output M codes during positioning.)  
However, no M code signals from the AD71S2 or A1SD71-S2 will be turned on in the speed control mode.
  - (b) Present values in an AD71 can be changed (rewritten) by a sequence program or peripheral device before positioning is started.
  - (c) Positioning can be done continuously by setting a positioning start data number to 20 points in the buffer memory (X axis: 0 to 39, Y axis: 300 to 339) in an AD71 before positioning starts in the position control mode.

The error compensation function and the backlash compensation function are valid in the parameter settings indicated below.

		Error Compensation	Backlash
Manual pulse		o	o
JOG		o	o *2
Zero return			
Positioning	Position control	o	o
	Speed/positioning control switching	o	o *1
	Speed control		o *2

o = valid

\*1 If the travel direction changes during restarting, backlash compensation is executed. When starting for the first time, backlash compensation is not executed.

- \*2 If a stop instruction is received during backlash compensation travel, it is controlled so that positioning is stopped after traveling the amount of the backlash.

Positioning control functions are shown below.

Function	Description
Error detection	An error code is provided by the AD71 if a data setting or positioning control error occurs. (For details of the error codes, refer to Chapter 8.)
Set data read and write	AD71 set data (parameters, zero return data, positioning data) can be read and written.
Present value and speed read	Present value data and speed data can be read from the AD71. (Present value can be read and monitored during positioning.)
Teaching (positioning data write)	After manual positioning, present value can be written as position data. (Data is written to both axes in the case of two-axes interpolation operations.)

#### POINTS

- (1) The AD71S1 type positioning module is for use exclusively with the Mitsubishi DC Servo Unit MELDAS-S1.

The functions, operation and specifications of the module are the same as those of the AD71 type positioning module, except for the I/O signal system and pin numbers.

- (2) The functions, operation and specifications are common to the A1SD71-S2 and AD71S2, and to the A1SD71-S7 and AD71S7, except for the following items:

- Number of I/O points
- Applicable CPUs
- Number of I/O slots occupied

For details, refer to Sections 2.2.1 and 3.2.

#### 3.4 General Description of Positioning System Operations

This section gives a general description of the AD71 and its use in a positioning system.

##### 3.4.1 Positioning system using an AD71

Fig. 3.1 shows the operation of an AD71 in a positioning system.

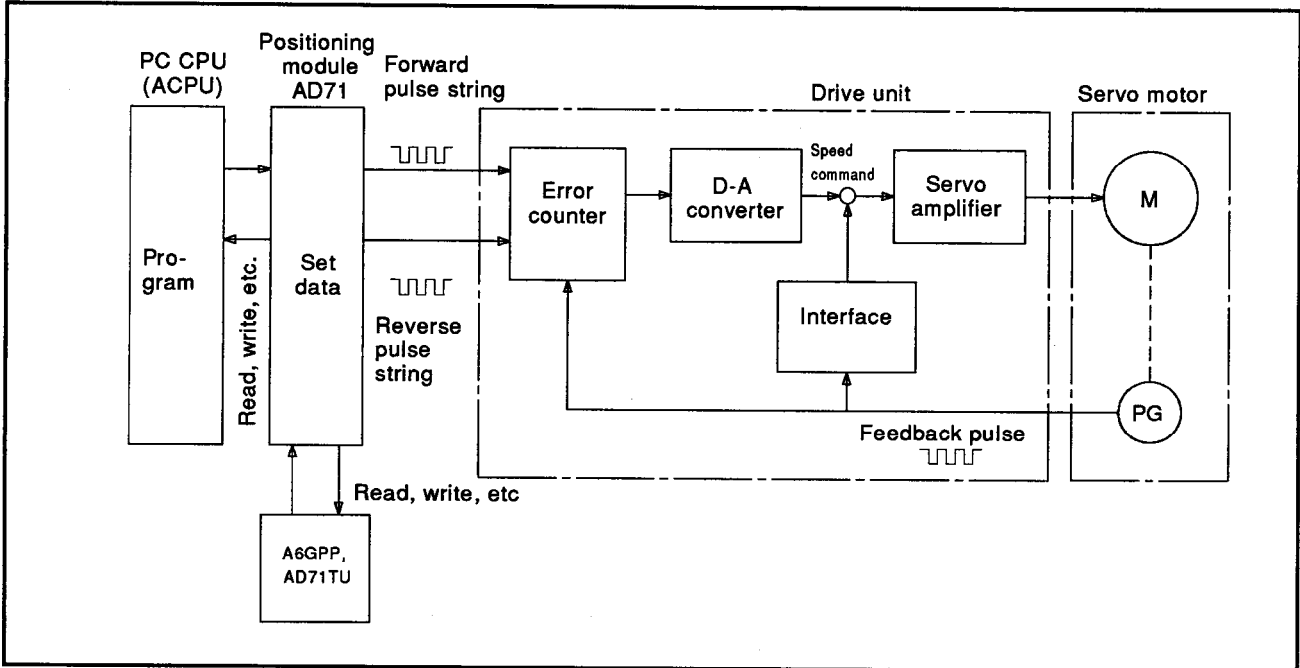
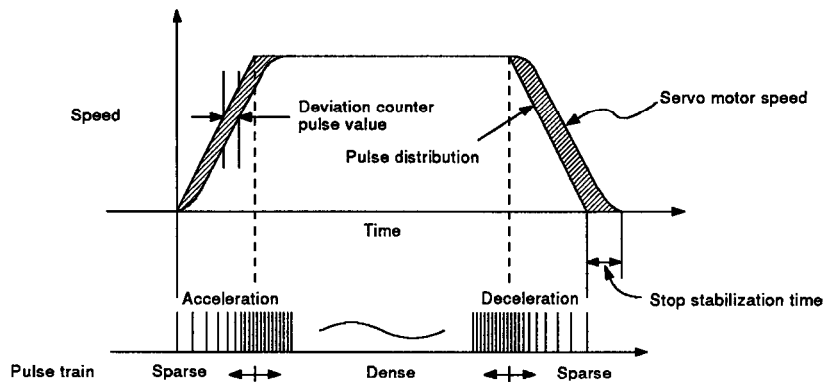

**Fig. 3.1 Positioning System Operation Block Diagram**

- (1) The AD71's output is a pulse string  
When pulse strings are output, pulses are converted into error counters. Deviation counter pulse values are converted into DC analog voltages by a D-A converter, and changed into speed commands.
- (2) The drive unit gives a speed command.  
The motor begins to rotate and the pulse generator PG gives feedback pulses in proportion to the revolutions of the motor to subtract accumulated pulses.  
The motor rotation continues maintaining the constant deviation counter pulse value.
- (3) When the command pulse output from the AD71 ceases, the deviation counter pulse value decreases, and the speed slows down.  
Then, when the deviation counter pulse value becomes 0, the motor stops.  
Thus, the motor's rotary speed is proportional to the frequency of the command pulse, and degree of the angle of the motor's rotation is proportional to the number of command pulse output pulses.  
Therefore, transmission can be done to a position that is proportional to the number of pulses of a pulse string by specifying the feedrate per pulse.  
The pulse frequency is equal to the number of revolutions (transmission speed) of the motor.

- (4) As shown in the following figure, while the pulse train is sparse when the motor accelerates, it is dense at the full speed. The pulse train becomes sparse again on deceleration, and the pulse reduces to zero. The motor comes to a stop slightly after the command pulse.

This time lag is called the stop stabilization time and it is required to ensure stopping accuracy.



General design of positioning system

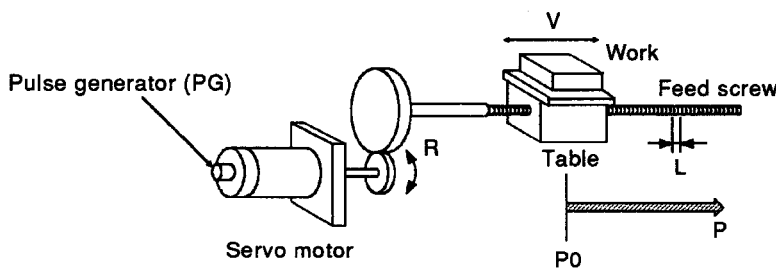

- A : Position detection increment (mm/p)
- Vs : Command pulse frequency (p/s)
- n : Number of pulse generator slits (slits/rev)
- L : Feed screw lead (mm/rev)
- R : Reduction ratio
- V : Moving part speed (mm/s)
- N : Motor speed (rpm)
- K : Position loop gain (sec<sup>-1</sup>)
- ε : Deviation counter pulse value
- P0 : Zero point (pulse)
- P : Address (pulse)

- (a) Position detection increment

$$A = \frac{L}{R \times n} \text{ (mm/p)}$$

- (b) Command pulse frequency

$$V_s = \frac{V}{A} \text{ (p/s)}$$

- (c) Deviation counter pulse value

$$\epsilon = \frac{V_s}{K} \text{ (pulse)}$$



Expression (1) indicates the travel per pulse, i.e. the number of output pulses  $\times A$ . Using expression (2), calculate the command pulse frequency from the work speed and position detection increment. Expression (3) indicates the relation between the command pulse frequency and deviation counter pulse value.

Any of the four positioning units, (mm), (inch), (degree), and (pulse), may be selected individually for the X and Y axes.

According to the target positioning address, a pulse string is output, and positioning is executed by the AD71 by setting data such as the travel distance and acceleration/deceleration time per pulse, the positioning speed, and the positioning address in a positioning command unit.

#### 3.4.2 Signal communications between an AD71 and each unit

Fig. 3.2 indicates the signal communications between the AD71 and external devices.

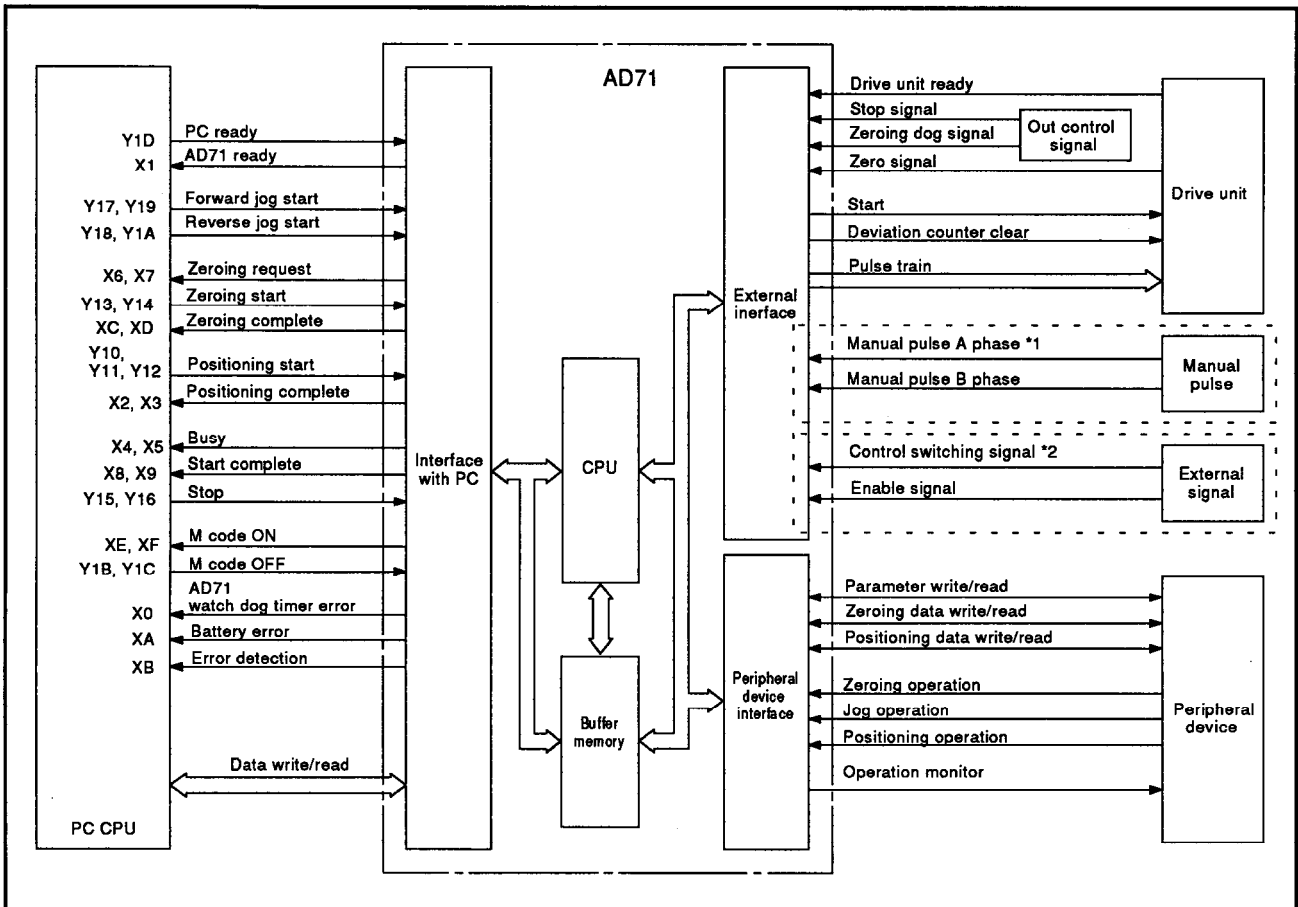

**Fig. 3.2 AD71 Function Block Diagram**

- (1) Communication between PC CPU and AD71  
Control signals and data communications via base unit.
- (2) Communication between A6GPP (or AD71TU) and AD71  
Data write, AD71 test, AD71 monitor, etc. via the AD71's RS422 connector.
- (3) Communications between drive unit and AD71  
Control signal communication to and from the drive unit and pulse train output from the AD71.
- (4) The manual pulse phase A signal \*1 shown in the above figure is sent when an AD71(S1/S7) or A1SD71-S7 is used.
- (5) The external signal \*2 in the figure above is sent when an AD71S2 or A1SD71-S2 is used.

3.4.3 AD71 operation description

Fig. 3.2 PC initiated positioning procedure

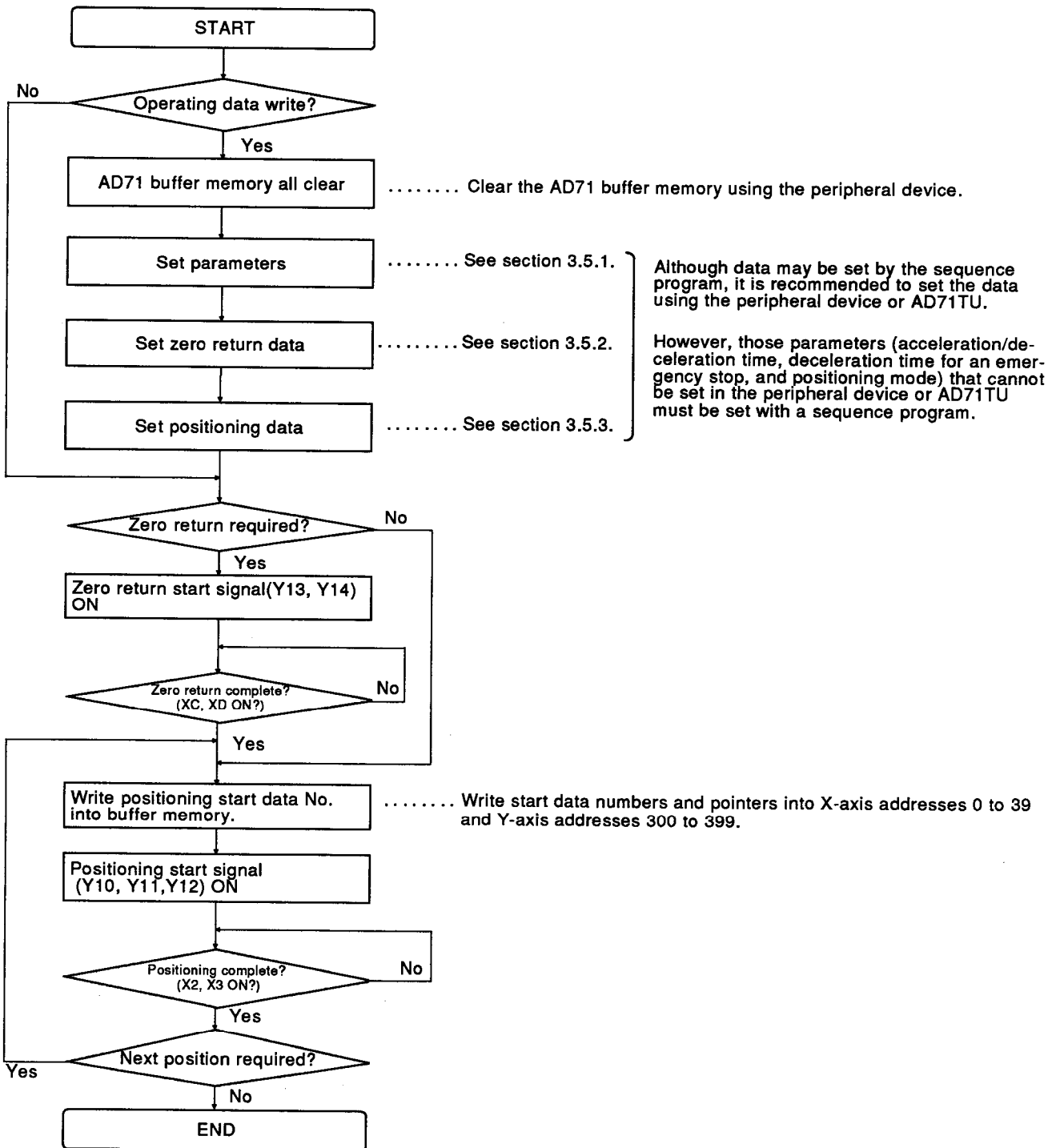

Table 3.4 shows the data needed for control signals (positioning functions) from the PC CPU.

### 3. SPECIFICATIONS

MELSEC-A

Table 3.4 Data Needed for Positioning Functions

Data		Functions	Manual Pulser Opera- tion	JOG Opera- tion	Zero Return	Positioning			Setting method	
						Posi- tioning Control	Speed/ Posi- tioning Control Switch- ing	Speed Control	AD71P or AD71TU	Sequence Program
Para- meter	Unit setting		○	○	○	○	○	○	○	○
	Travel per pulse		○	○	○	○	○	○	○	○
	Speed limit value			○	○	○	○	○	○	○
	Jog speed limit value			○					○	○
	Starting bias speed			○	○	○	○	○	○	○
	Backlash compensation		○	○		○	○		○	○
	Upper stroke limit					○	○		○	○
	Lower stroke limit					○			○	○
	Error compensation		○	○		○	○		○	○
	Travel per manual pulse during inching		○						○	○
	Acceleration and deceleration times			○	○	○	○	○	○*1	○
	Positioning complete signal output time					○	○		○	○
	Pulse output mode		○	○	○	○	○	○	○	○
	Rotation direction setting		○	○	○	○	○	○	○	○
	Positioning method					○			○	○
	M code ON/OFF timing					○	○		○	○
	Deceleration time for emergency stop			○	○	○	○	○	X	○
	Positioning mode					○	○	○	X	○
Zero return data	Zero return direction		○	○	○	○	○		○	○
	Zero return method				○				○	○
	Zero return address		○	○	○	○	○		○	○
	Zero return speed				○				○	○
	Zero return creep speed				○				○	○
	Zero return dwell time				○				○	○
	Torque limit				○				○	○
Posi- tioning data	Positioning information					○	○	○	○	○
	Positioning speed					○	○	○	○	○
	Positioning address					○	○		○	○
	Dwell time					○	○		○	○
Others	Start data number area					○	○	○	○	○
	Speed change data			○	○	○	○	○	X	○
	Jog speed			○					○	○
	Manual pulse generator enabled		○						○	○
	Pulse output speed during manual pulse generator operation		○						X	○

\*1: Use a sequence program to set the acceleration time at a value between 5000 ms to 50000 ms when using an AD71S2 or A1SD71-S2.

#### 3.5 Types and Functions of Setting Data

To perform positioning control, three different data, i.e. parameters, zero return data and positioning data, must be set.

They may be written by either of the following two methods.

- 1) Using AD71P or AD71TU
- 2) From sequence program (FROM, TO instructions)

It is necessary set data for two (X and Y) axes.

#### POINT

##### (1) Clearing all data

When the module is used for the first time after it was purchased, or if the capacitor backup time of 5 minutes (7 minutes for the A1SD71-S2(S7)) is exceeded due to the disconnection of the AD71 battery connector, clear all memory from the peripheral device or sequence program.

When the AD71S2 or A1SD71-S2 is used, the following data cannot be cleared by the peripheral device. Therefore, write "0" from the sequence program.

- 1) Deceleration time for sudden stop
- 2) Positioning mode

If power is switched on without all clear processing, a HOLD error (error No. 51) may occur.

The following shows a sequence program example that clears the parameter and zero return data areas.

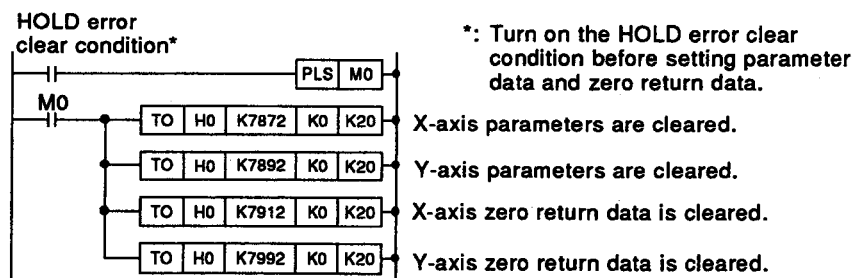

##### (2) Data setting when either the X or Y axis is used

Even when using either the X or Y axis, write parameter and zero return data to the axis not used.

( Written data must be values in the setting ranges given in this manual. )  
 ( The parameters may be initial values (default values). )

If zero return is done without data being written, an error occurs and the Xob (error detection) signal turns on.

##### (3) Parameter initialization

When no parameters have been set or any one parameter is erroneous (outside the setting range), all data are controlled as initial values given in Table 3.5.

However, the parameter area data remain unchanged from the user settings.

#### 3.5.1 Parameters

Parameters are the basic data which enable the AD71 to do positioning control. The data in Table 3.5 is contained in parameters.

Parameters are checked when:

- 1) The power is turned ON;
- 2) Parameters are sent from a peripheral device to an AD71;
- 3) A PC CPU ready signal from the PC CPU to the AD71 switches from OFF to ON;
- 4) (1) zero return, (2) positioning, (3) jog operation, or (4) inching has been selected in the peripheral device test mode.

However, error code and error detection signals are not given for 1) above (power ON parameter check).

- Though travel per manual pulse during inching is not used with an AD71 or A1SD71-S2, set any value in the setting range.
- The following parameters in Table 3.5 must be set with a sequence program (refer to Section 3.6.4.)
  - 1) Item No. 11\*1 ..... Acceleration/deceleration time  
(When setting a value of 5000 msec or more)
  - 2) Item No. 17 ..... Deceleration time for an emergency stop
  - 3) Item No. 18 ..... Positioning mode

### 3. SPECIFICATIONS

Table 3.5 Parameter Settings

No.	Items	mm		inch		degree		pulse		Initial Values	Units
		Setting Ranges	Units	Setting Ranges	Units	Setting Ranges	Units	Setting Ranges	Units		
1	Units	0	—	1	"	2	"	3	"	3	"
2	Travel per pulse	1 to 100	X10 <sup>-1</sup> µm/PLS	1 to 100	X10 <sup>-5</sup> inch/PLS	1 to 100	X10 <sup>-5</sup> degree/PLS	—	"	"	"
3	Speed limit values	1 to 12000	X10 <sup>1</sup> mm/min	1 to 12000	X1 inch/min	1 to 12000	X1 degree/min	1 to 20000	X10 <sup>-1</sup> pulse/s	20000	X10 <sup>-1</sup> pulse/s
4	Jog speed limit values	1 to 12000	X10 <sup>1</sup> mm/min	1 to 12000	X1 inch/min	1 to 12000	X1 degree/min	1 to 20000	X10 <sup>-1</sup> pulse/s	2000	X10 <sup>-1</sup> pulse/s
5	Starting bias speeds	1 to 12000	X10 <sup>1</sup> mm/min	1 to 12000	X1 inch/min	0 to 12000	X1 degree/min	0 to 20000	X10 <sup>-1</sup> pulse/s	0	X10 <sup>-1</sup> pulse/s
6	Backlash compensation	0 to 65535	X10 <sup>-1</sup> µm	0 to 65535	X10 <sup>-5</sup> inch	0 to 65535	X10 <sup>-5</sup> degree	0 to 255	pulse	0	pulse
7	Upper stroke limits	0 to 162000	mm	0 to 16200	inch	0 to 16200	degree	0 to 16252928	pulse	16252928	pulse
8	Lower stroke limits	0 to 162000	mm	0 to 16200	inch	0 to 16200	degree	0 to 16252928	pulse	0	pulse
9	Error compensation	±0 to 100000 (per m)	X10 <sup>-1</sup> µm	±0 to 100000 (per 100 inch)	X10 <sup>-5</sup> inch	±0 to 100000 (per degree)	X10 <sup>-5</sup> degree	—	"	0	"
10	Travel per manual pulse during inching	1 to 100000	X10 <sup>-1</sup> µm	1 to 100000	X10 <sup>-5</sup> inch	1 to 100000	X10 <sup>-5</sup> degree	1 to 100	pulse	1	pulse
11	Acceleration and deceleration times	64 to 4999(ms) *1								1000	ms
12	Positioning complete signal output time	1 to 20000(ms)								300	ms
13	Pulse output mode	0: pulse + SIGN (B type) 1: Forward pulse or reverse pulse (A-type)								Same as the previous setting *	
14	Direction setting	0: Present value increase when forward pulse is output 1: Present value increase when reverse pulse is output								Same as the previous setting *	
15	Positioning method	0: Absolute 1: Incremental 2: Incremental/absolute combined								0=absolute	
16	M code ON/OFF timing	0: M code not used 1: M code used { 0: WITH mode 1: AFTER mode								Same as the previous setting *	
17	Deceleration time for emergency stop *2	64 to 50000(ms)								1000	ms
18	Positioning mode *2	0: Positioning control mode 1: Speed/positioning switching control mode 2: Speed control mode								0=positioning control	

- \* :Not fixed when shipped from the factory. All clear set to 0.
- \*1:The parameter can be set in a range between 64 ms and 50000 ms when an AD71S2 or A1SD71-S2 is used. (A value of 5000 ms or more must be set with a sequence program.)
- \*2:Set the parameter only when an AD71S2 or A1SD71-S2 is used.

The actual parameter speed limit values and JOG speed limit values in Table 3.5 are multiplied by 6.1 (pulse/s).

For example, the value that is nearest to 200 (pulse/s) is multiplied by 6.1 (pulse/s), even if the speed limit value is set to 200 (pulse/s).

$$200 \div 6.1 = 32.78688.....(\text{Decimal point values are rounded off.})$$

The actual speed is 6.1 x 32 = 195.2 (pulse/s).

**POINTS**

- (1) Numbers 2 to 12 show the setting range when setting with a sequence program.  
 However, parameters whose unit is  $\times 10^{-1}$  or  $\times 10^1$  are processed automatically as  $\times 10^{-1}$  or  $\times 10^1$  in the AD71 when processed with a value set in the program.  
 (Example) If the speed limit value is set to 200, the value becomes  $2000 \times 10^1 = 20000$  mm/min in the A1SD71.
- (2) Number 10 - travel per manual pulse during inching is not used with the AD71S2/A1SD71-S2.  
 However, when setting it by using SW0GP-AD71P or AD71TU, the value must be set within the setting range.
- (3) Numbers 17 and 18 must be set with a PC CPU program.

Parameter data is explained as follows.

(1) Unit

Selects the units (mm, inch, degree, or pulse) for positioning control. Can be set independently for X and Y axes (e.g. X axis = mm, Y axis =degree).

(2) Travel per pulse

- Specifies the travel distance per pulse as determined by the mechanics of the system.
- Controls the number of pulses contained in the pulse train from the AD71.

(3) Speed limit value

- Specifies the maximum speed for positioning (or zero return).
- When the positioning speed called at a given time is greater than the speed limit value, the speed is limited to the value set by the parameter.
- When a new speed is called during positioning by the sequence program and this is greater than the speed limit value, the speed is limited to the value set by the parameter.
- Set the speed limit value within the range of the following expression according to the travel per pulse.

$$\frac{V \text{ (unit/min)}}{\{a \text{ (unit/pulse)}\} \times 60} \leq 200,000 \text{ (pulse/s)}$$

V: Speed limit value (unit/min)  
a: Travel per pulse (unit/pulse)

Example) When the travel per pulse is 1 ( $\mu$ m/pulse)

$$\frac{V \text{ (unit/min)}}{\{a \text{ (mm/pulse)}\} \times 60} \leq 200,000 \text{ (pulse/s)}$$

$$\leq 200,000 \text{ (pulse/s)} \times 0.001 \text{ (mm/pulse)} \times 60$$

$$\underline{V \leq 12,000 \text{ (mm/min)}}$$

When the travel per pulse is 1 ( $\mu$ m/pulse), set the speed limit value to 12,000 (mm/min) or less.

(4) Jog speed limit value

- Specifies the maximum speed for jog operation.
- The jog speed limit value must be within the range shown in Table 3.5 and must not exceed the speed limit value.
- When the jog speed set using the peripheral device or sequence program is greater than the jog speed limit value, the jog speed is kept to the limit value.

\* For jog operation, refer to Section 6.3.6.



(5) Starting bias speed

- A minimum starting speed is required for the smooth operation of some motors (e.g. stepping motors). This may be set as a starting bias speed.
- The starting bias speed is used for positioning, jog operation, and zero return. See Fig. 3.3.

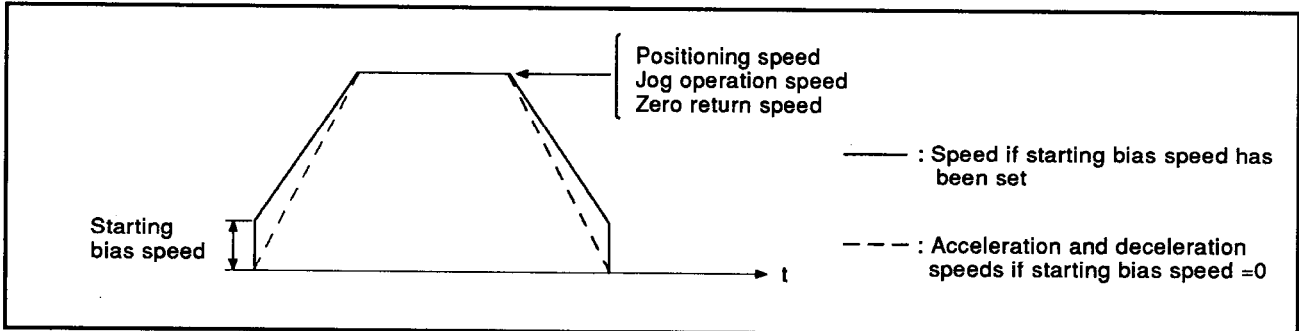

Fig. 3.3 Speed Change When Starting Bias Speed is Set

For positioning with interpolation between axes, the starting bias speed set for the axis with the shorter distance to travel is ignored.

Definition of a master axis and a slave axis during interpolation positioning

	Speed Control Mode	Positioning Control Mode
Master axis	Axis with a fast positioning speed	Axis of which a travel distance is long
Slave axis	Axis with a slow positioning speed	Axis whose travel distance is short

(6) Backlash compensation

- Allows a backlash compensation (see Fig. 3.4) to be programmed in for accurate positioning. Note that there is also an error compensation facility to allow for tolerances within the mechanical drive, see note (9).
- When backlash compensation is set, every time the travel direction changes during positioning in the positioning control mode, a feed pulse occurs which exceeds the backlash compensation amount.  
If the travel direction when restarting positioning in the speed/positioning control switching mode differs from the travel direction at the initial start, a feed pulse occurs which exceeds the backlash compensation amount.  
This applies when positioning is stopped, and the travel direction is changed by changing the present value after switching to positioning control.
- Each time the travel direction changes during manual pulse generator operation, feed pulses which can compensate for the input pulses in excess of the backlash compensation amount are generated.  
(When the number of input pulses is smaller than the backlash compensation amount, the AD71(S1/S7) or A1SD71-S7 stores the input pulses internally, but no feed pulse is generated.)
- The feed pulse for a backlash compensation amount is generated at by least one JOG start signal during the JOG operation. Therefore, even if the travel distance is smaller than a backlash compensation amount, the feed pulse for a backlash compensation amount occurs.

- Backlash compensation is valid after zero return. After redefining the backlash compensation, always zero the system.

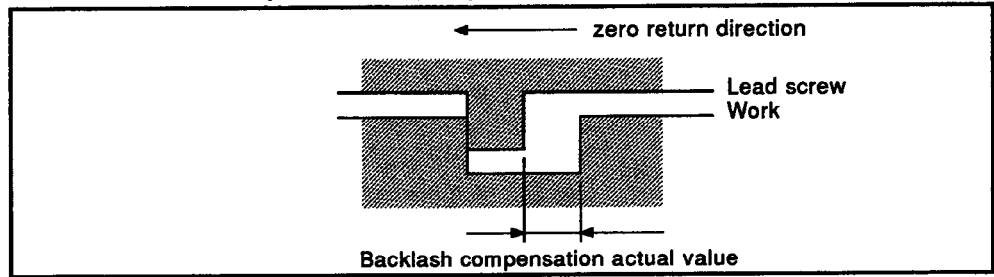

**Fig. 3.4 Backlash Compensation**

- For the backlash compensation amount, the range of the number of output pulses differs in accordance with the unit to be set in the parameter.

Setting Units	Number of Output Pulses
pulse	0 to 255
mm	*0 to 65535
inch	
degree	

The \* symbol indicates the value when the travel distance per pulse is set to 1.

**(7) Upper stroke limit**

- Defines the upper limit value of machine travel.
- The stroke limit is checked before each positioning operation and if outside the allowed range, positioning is halted. During jog operation and manual pulser inching, the stroke limit is ignored.

**(8) Lower stroke limit**

- Defines the lower limit value of machine travel.
- The stroke limit is checked before each positioning operation and if outside the allowed range, positioning is halted. During jog operation and manual pulser inching, the stroke limit is ignored.
- The lower stroke limit during operations in the speed control mode and the speed/positioning control switching mode is considered 0, independently of the parameter set value. However, set the lower stroke limit in the range of 0 to the upper stroke limit to prevent a parameter setting error.

**REMARK**

The present values in the AD71S2/A1SD71-S2 buffer memory area becomes the following numerical values:

Operating Modes	Present Values (X axis: addresses 602 and 603 Y axis: addresses 604 and 605)
Speed control mode	Always 0
Speed/positioning control switching mode	Speed control mode: always 0 Positioning control mode Increases sequentially from 0.

## (9) Error compensation

When the set value and an actual feedrate differ is called error compensation.

When the unit is mm, an error compensation per m (per 100 inches if the unit is inches and per 100 degrees if the unit is degrees) is set to 0, and the feedrate of any set value is transmitted. (Automatic start) Then, the actual feedrate (A) is measured, and the error compensation amount and backlash compensation amount are calculated as indicated below.

Errors are compensated during JOG operation or positioning.

- When the unit is mm

$$\text{Error compensation amount (10}^{-1}\mu\text{m)} = \left( \frac{\text{Setvalue(mm)}}{A \text{ (mm)}} - 1 \right) \times 10^7$$

- When the unit is inches

$$\text{Error compensation amount (10}^{-5}\text{ inch)} = \left( \frac{\text{Setvalue(inch)}}{A \text{ (inch)}} - 1 \right) \times 10^7$$

- When a unit is degrees

$$\text{Error compensation amount (10}^{-5}\text{ degree)} = \left( \frac{\text{Setvalue(degree)}}{A \text{ (degree)}} - 1 \right) \times 10^7$$

- Set the numerical value calculated in the following expression as the backlash compensation amount when there is a machine error.

$$\text{Backlash compensation} = \text{Backlash compensation actual value} \times \frac{\text{Setvalue}}{A}$$

## (10) Manual pulse inching travel increment

- Set the travel distance per manual pulse.
- The AD71(S1/S7) or A1SD71-S7 counts the number of input pulses, converts into the travel distance, and transmits the equivalent number of pulses to the drive unit.  
(The output speed is fixed at 20000 pulse/s in the case of the AD71(S1), and adjustable in 10 pulse/s units in the range from 10 pulse/s to 20000 pulse/s in the case of the AD71S7/A1SD71-S7.)
- Automatic acceleration will not be performed during manual pulse operation.

**POINT**

Always set a value for the travel distance per manual pulse generator pulse, even in the following cases:

- When no manual pulse generator is used
- When an AD71S2 or A1SD71-S2 is used

(If a value outside the setting range is set an error will occur.)

(11) Acceleration and deceleration times

- Defines the period of time from the start of positioning to when the speed limit value specified in the parameter is reached. (Refer to Fig. 3.5.)

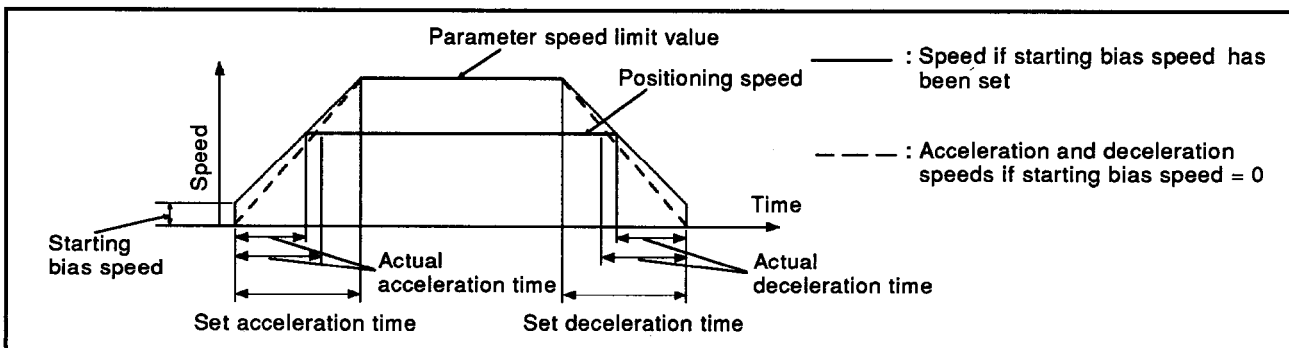

Fig. 3.5 Acceleration and Deceleration Times

- The acceleration time is the same as the deceleration time. They cannot be set differently.
- The acceleration and deceleration are controlled at a constant value.
- When the positioning speed is lower than the parameter speed limit, the acceleration and deceleration times are comparatively short. Therefore, the maximum positioning speed must be either equal to the parameter speed limit or an approximate value.
- The acceleration and deceleration times are valid for zero return, positioning, and jog operations.
- For interpolation positioning, the acceleration and deceleration times for a master axis are valid. (The acceleration and deceleration times for a slave axis are ignored.)

Definition of a master axis and a slave axis during interpolation positioning

	Speed Control Mode	Positioning Control Mode
Master axis	Axis with a fast positioning speed	Axis whose travel distance is long
Slave axis	Axis with a slow positioning speed	Axis whose travel distance is short

- Acceleration and deceleration times can be set within the range of 64 to 50000 msec by using an AD71S2/A1SD71-S2. When inputting from a teaching module (SW0GP-AD71P, AD71TU), 64 to 4999 msec can be set. If the acceleration and deceleration times are set within the range of 5000 to 50000 msec, data must be written to the parameter area using a sequence program. (Hexadecimal input)
- (17) Deceleration time for an emergency stop gives details about an emergency stop in a shorter time than the deceleration times given above.

(12) Positioning complete signal duration

Sets the duration of the "positioning complete signal" from the A1SD71. Positioning is considered to be complete after the A1SD71 terminates pulse output and the predetermined dwell time has elapsed. A positioning complete signal is not output in the speed control mode.

(13) Pulse output mode

Defines the output mode as A type or B type.

- Forward pulse or reverse pulse, two pulse chains.

Forward feed pulse PULSE F	PULSE F		A type
Reverse feed pulse PULSE R	PULSE R		

- PLS + SIGN

Feed pulse PULSE	Forward and reverse feed pulses. Travel direction is controlled by direction sign (SIGN).		B type
Direction sign SIGN	Low in forward direction. High in reverse direction. (Present value increases in forward direction and decreases in reverse.)		

Set the pulse input mode to PLS + SIGN when using an AD71S1.

(14) Direction setting

Selects the direction for which the present value increases. (Set 0 when using forward pulse output. Set 1 when using reverse pulse output.) Positioning and zero return follow this direction of rotation.

(15) Positioning methods

- Specifies incremental, absolute, or incremental/absolute combination modes for positioning.
- In incremental mode positioning, positions are reached with reference to the previous position. (See Fig. 3.6.)

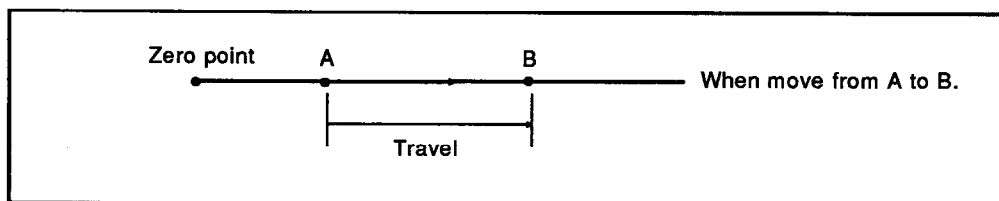

Fig. 3.6 Incremental Method

- In absolute mode positioning, positions are reached with reference to a Zero point address. (See Fig. 3.7.)

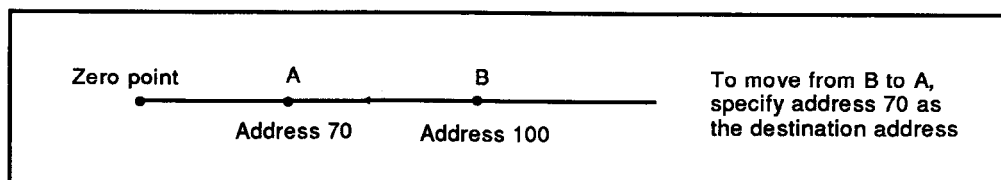

Fig. 3.7 Absolute Method

- To use both incremental and absolute modes in the same axis (e.g. X axis), set 2. In this case, the mode is controlled by the individual piece of positioning data. (Refer to Section 3.5.3.)

(16) M code ON/OFF timing

M codes are code numbers (1 to 255) assigned by the user to control auxiliary functions (for example, clamp, drill rotation, stop, and tool exchange commands, etc.) at defined points in the positioning cycle. These are used by the PC CPU to co-ordinate the operation of external equipment and processes.

- M code use/non-use must be specified as well as where in the positioning sequence they are to be used.  
When M code non-use is specified or peripheral device test mode is in operation, M code data in the buffer memory is cleared and the "M code ON" signal is not output.
- When the M code used is specified, the output timing of the M code ON signal must be specified.
- "M code ON" signal output is available in two timing modes, WITH and AFTER.

(a) WITH mode

The "M code ON" signal is given at approximately the same time as the positioning operation starts.

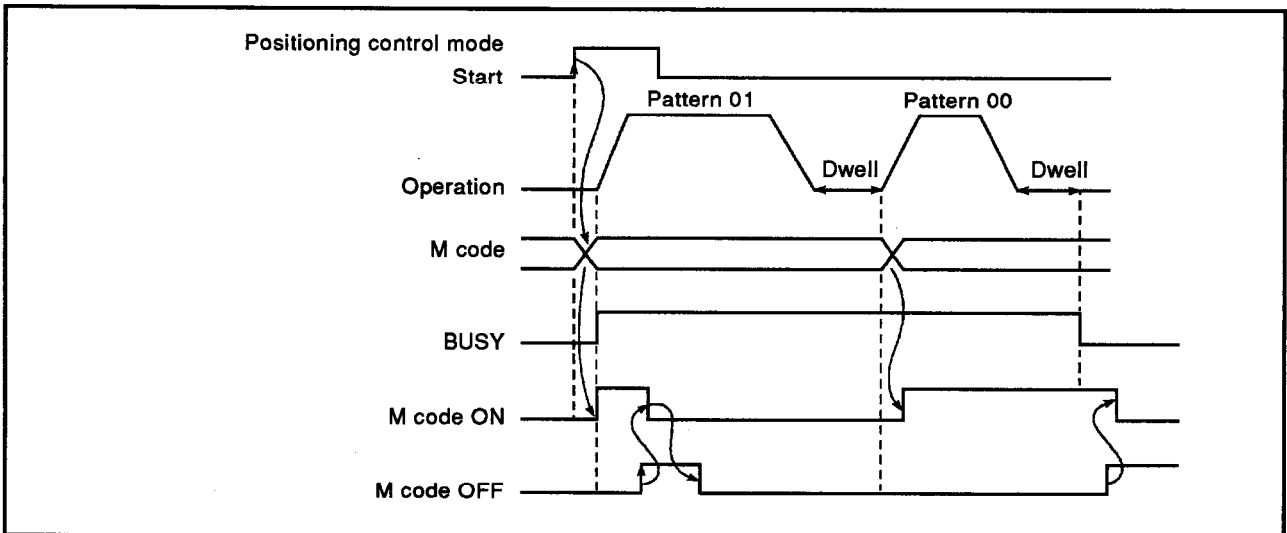

Fig. 3.8-1 WITH Mode Signal Timing

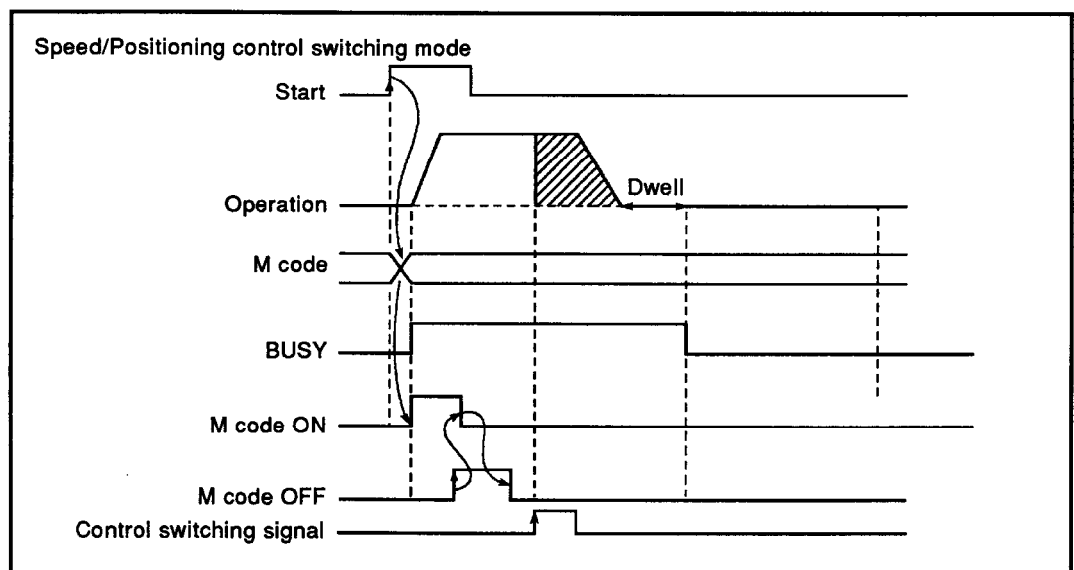

Fig. 3.8-2 WITH Mode Signal Timing

**Note :** The WITH code ON signal does not turn ON during restarting in the switching mode.

(b) AFTER mode

The "M code ON" signal is given after the positioning operation has finished. In this mode, if the operation is stopped before it is complete the "M code ON" signal is not given.

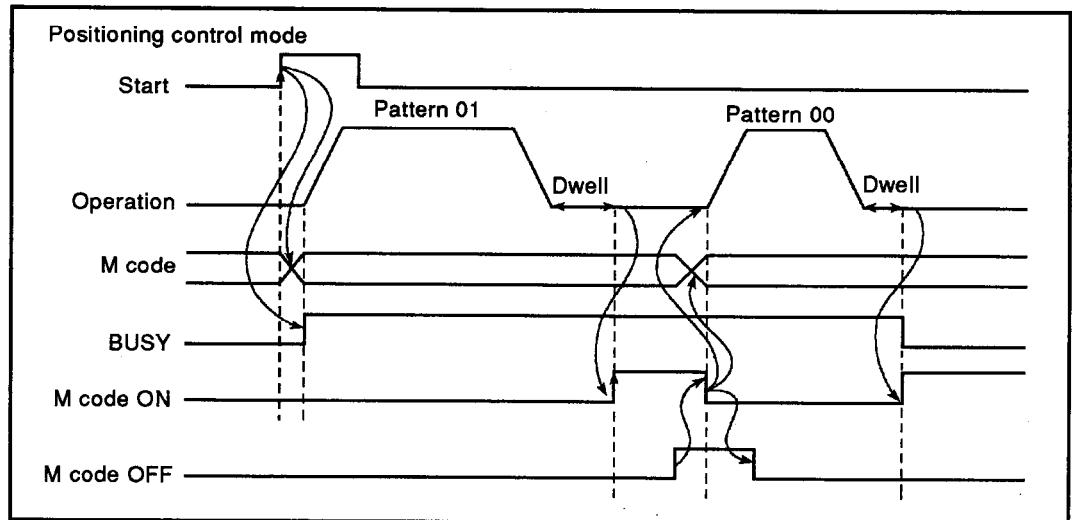

Fig. 3.9-1 AFTER Mode Signal Timing

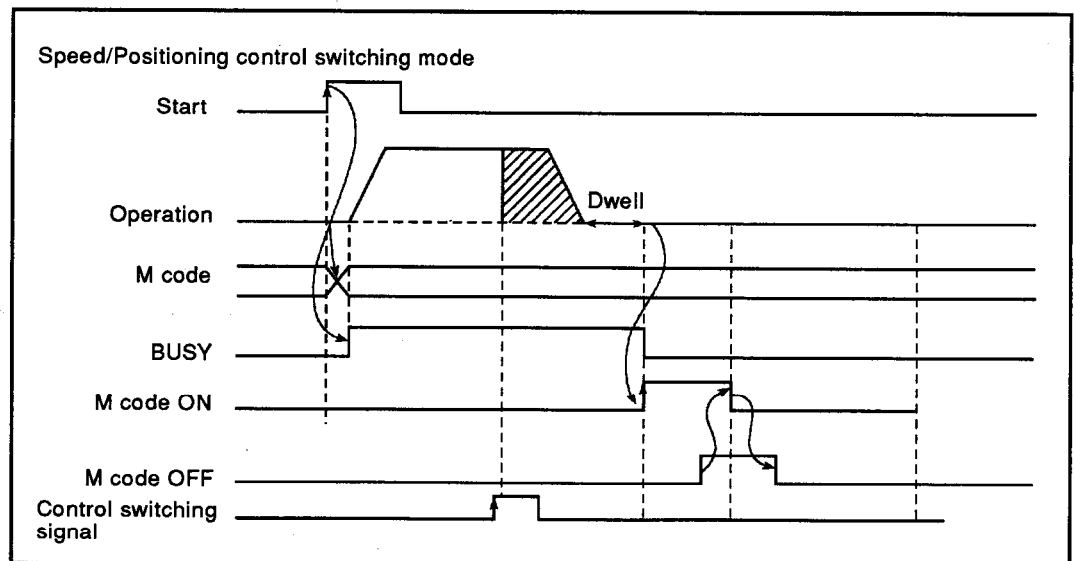

Fig. 3.9-2 AFTER Mode Signal Timing

POINTS
<ul style="list-style-type: none"> <li>• The "M code ON" signal is not given if the M code data in the positioning data is set at 0.</li> <li>• The M code is ignored if the positioning pattern is "11" and the "M code ON" signal is not given. (For details of the positioning pattern, refer to Section 3.5.3.) The next positioning operation is not started until the "M code ON" signal is switched off. An error condition arises if the "M code ON" signal is on at the rise of the start signal and positioning is not started. The "M code ON" signal is turned off when:               <ol style="list-style-type: none"> <li>1. "M code OFF" signal changes from OFF to ON;</li> <li>2. PC ready signal (Y1D) is OFF; or</li> <li>3. zero return, positioning, jog operation, or inching mode is selected in the peripheral device or the AD71TU test mode.</li> </ol> </li> <li>• The M code ON signal does not turn ON during positioning in the speed control mode.</li> </ul>

- Positioning control mode  
When positioning processing beginning with pattern 11 is executed, the M code ON signal goes ON when positioning processing of pattern 00 or pattern 01 begins in the WITH mode or when completed in the AFTER mode.  
The M code is set before pattern 11 positioning processing begins.

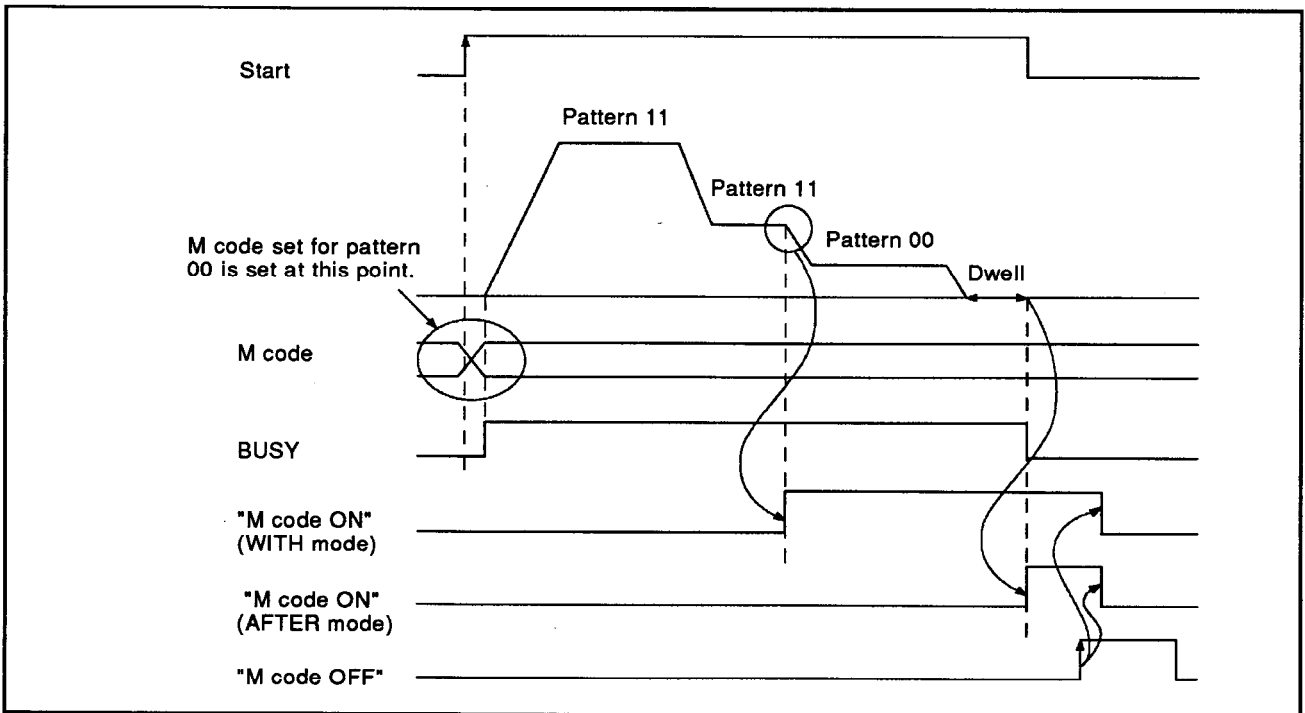

Fig. 3.10 "M Code ON" Signal Timing for Positioning Pattern "11"

**REMARK**

Fig. 3.10 shows the M code ON signals in the WITH mode and the AFTER mode. However, this is only to explain the M code ON signal, and either (WITH mode or AFTER mode) can actually be used.



**POINT**

When restart positioning is executed in the speed/positioning control switching mode, the M code ON signal of the WITH mode does not go ON.

(17) Deceleration time for an emergency stop(when AD71S2/A1SD71-S2 is used)

- Sets the deceleration time (64 to 50000 msec, setting unit: 1 msec) when there is an emergency stop during JOG, zero return, and positioning operations.
- The deceleration time for an emergency stop must be written in the parameter area (buffer memory addresses X axis: address 7888 and Y axis: address 7908) using a sequence program. (Hexadecimal input)
- When decelerating, designate either deceleration time or the usual acceleration/deceleration time (addresses X axis: 7876, Y axis: 7896) for an emergency stop to use positioning start data in the emergency stop area (addresses X axis: 202, Y axis: 502).

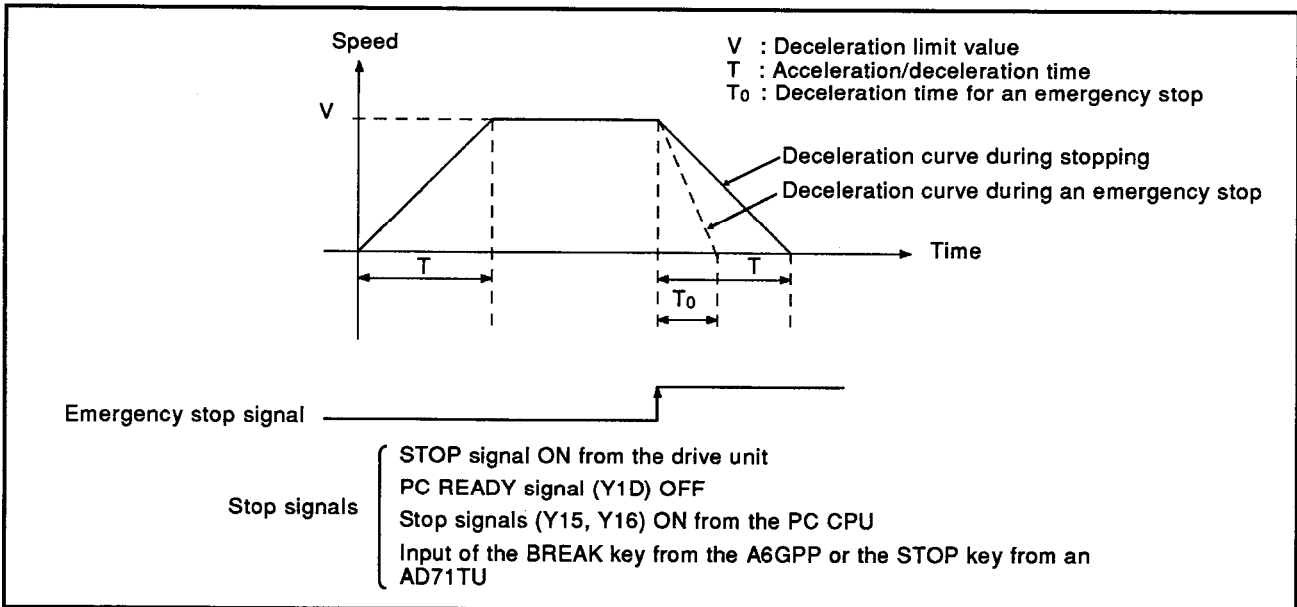

### 3. SPECIFICATIONS

(18) Positioning mode (when AD71S2/A1SD71-S2 is used)

- Sets the control mode when executing positioning.
- The same positioning mode to the X axis and Y axis in a parameter area (buffer memory address 7889) must be written with a sequence program.

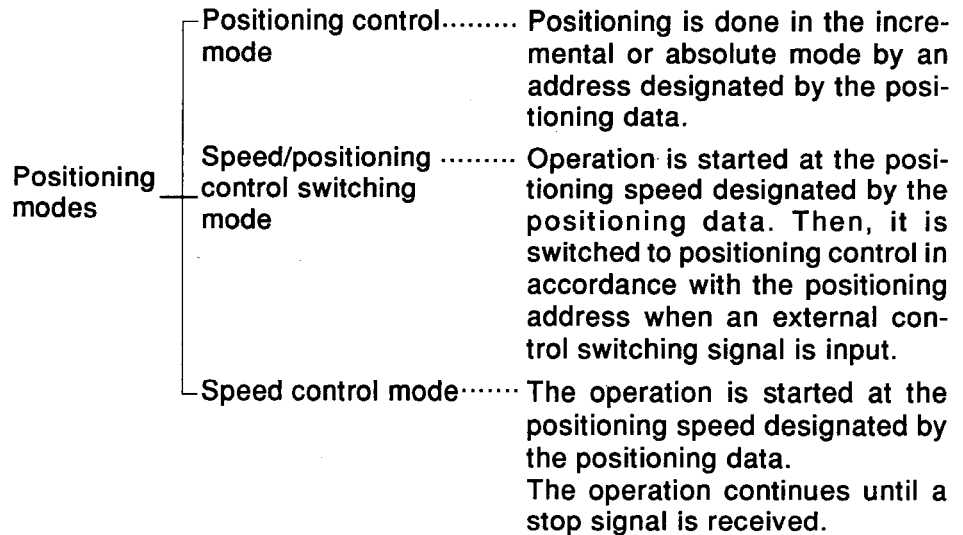

- Section 3.5.4 gives details about the positioning mode.

**POINTS**

- The positioning mode is a parameter that is common to both the X and Y axes. Axes cannot be set to different positioning modes. The X-axis parameter area does not have a one-word setting area. The Y-axis parameter area does not have a positioning mode area.
- When setting a positioning mode causes an error, error buffer memory 90 (memory addresses X axis: 45 and Y axis: 345) is set to both the X and Y axes, and the parameter is controlled by the initial value.

When an error occurs in the parameter, the parameter is controlled as follows by the initial value.

Positioning Mode		With an Error	Without an Error
Parameter other than the Positioning Mode			
X axis	With an error	<ul style="list-style-type: none"> <li>• Switches to the positioning control mode.</li> <li>• The parameter of the X and Y axes is controlled by initial value.</li> </ul>	A parameter other than the positioning mode is controlled by the initial value.
	Without an error		All parameters are controlled by the specified values.
Y axis	With an error		A parameter other than the positioning mode is controlled by the initial value.
	Without an error		All parameters are controlled by the specified values.

### 3. SPECIFICATIONS

MELSEC-A

#### 3.5.2 Zero return data

This defines a home position or zero point for the AD71. Refer to Table 3.6. Zero return data is checked when:

- 1) parameters or zero return data is transferred from the peripheral device to the AD71;
- 2) "PC ready signal" output from the PC CPU to the AD71 changes from OFF to ON; or
- 3) Zero return, positioning, jog operation, or manual pulser inching is selected in the peripheral device test mode.

**Table 3.6 Zero Return Data**

No.	Item	mm		inch		degree		pulse	
		Setting Range	Unit	Setting Range	Unit	Setting Range	Unit	Setting Range	Unit
1	Zero return direction	0 : Forward direction (address increases) 1 : Reverse direction (address decreases)							
2	Zero return method	0 : Pulse generator(PG)zero-point signal 1 : Stopper stop (1) and dwell timer time-out 2 : Stopper stop (2) and signal from drive unit							
3	Zero return address	0 to 162 × 10 <sup>7</sup>	× 10 <sup>-1</sup> μm	0 to 162×10 <sup>7</sup>	×10 <sup>-5</sup> inch	0 to 162 ×10 <sup>7</sup>	×10 <sup>-5</sup> deg	0 to 16252928	pulse
4	Zero return speed	1 to12000	× 10 <sup>1</sup> mm/min	1 to12000	×1 inch/min	1 to12000	×1 deg/min	1 to 20000	×10 <sup>1</sup> pulse/s
5	Creep speed	1 to12000	×10 <sup>1</sup> mm/min	1 to12000	×1 inch/min	1 to12000	×1 deg/min	1 to 20000	×10 <sup>1</sup> pulse/s
6	Zero return dwell time	0 to 499(×10 <sup>1</sup> ms)							
7	Torque limit	10 to 250(%)							

#### POINTS

- (1) No. 3 to No. 7 can be set by the sequence program.
- (2) Setting numbers "0 and 1" of the zero return direction and setting numbers "0, 1, and 2" of the zero return method are numbers set by a peripheral device.  
When setting No. 1 and No. 2 from the sequence program, refer to Section 3.6.6.

#### REMARK

The zero return speed and creep speed in Table 3.6 are multiplied by 6.1 (pulse/s).  
For example, the value that is nearest to 200 (pulse/s) is multiplied by 6.1 (pulse/s), even if the speed limit value is set to 200 (pulse/s).  
200 ÷ 6.1 = 32.78688.... (Decimal point values are rounded off.)  
The actual speed is 6.1 × 32 = 195.2 (pulse/s)

Zero return data is explained below:

- (1) Zero return direction
  - Specifies the direction for zero return.

**IMPORTANT**

Zero return is controlled according to the zero return direction and speed. Deceleration is started when an actuator is operated. Always ensure that the zero return direction is correct for the drive system used.

- (2) Zero return methods

There are three kinds of zero return methods:

- The pulse generator (PG) zero-phase signal method
- Mechanical stop (1) (caused by dwell timer time)
- Mechanical stop (2) (caused by a signal from the drive unit)

- (a) Method by the pulse generator (PG) zero-phase signal method

This method of stopping by a zero-phase signal from the PG is shown in Fig. 3.11.

A PG with a zero-phase signal is necessary. (Refer to Fig. 3.12.)

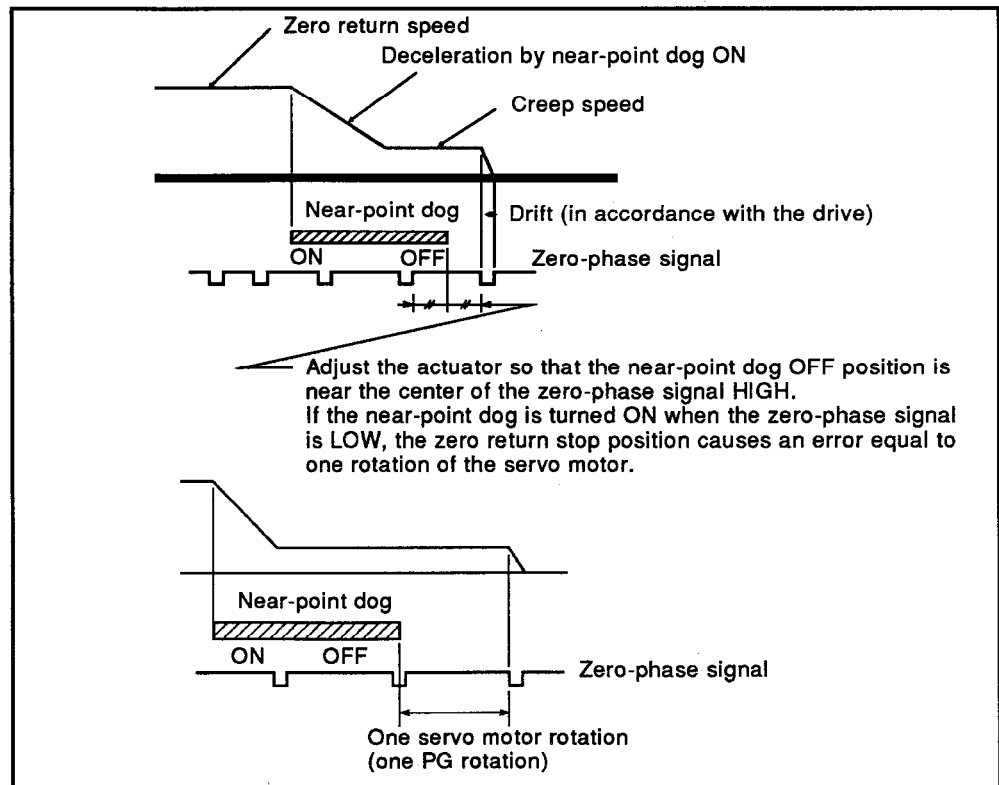

**Fig. 3.11 Zero Return Using a PG Zero-Phase Signal**

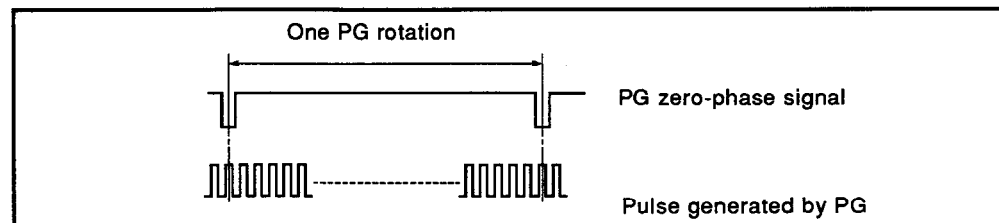

**Fig. 3.12 Feedback Pulse Pattern**

- (b) Mechanical stop (1) (caused by a dwell time time-out)
 

After a near-point dog has operated and the dwell time has passed, zero return is completed. (Refer to Fig. 3.13-1.)

In this case, if the dwell time has not passed, even if the near-point dog goes OFF halfway, zero return is not completed. After reaching the creep speed, limit the servo motor torque (Section 3.5.2(7) gives details).

If the servo motor torque is not limited, the servo motor may malfunction when a stopper is hit.

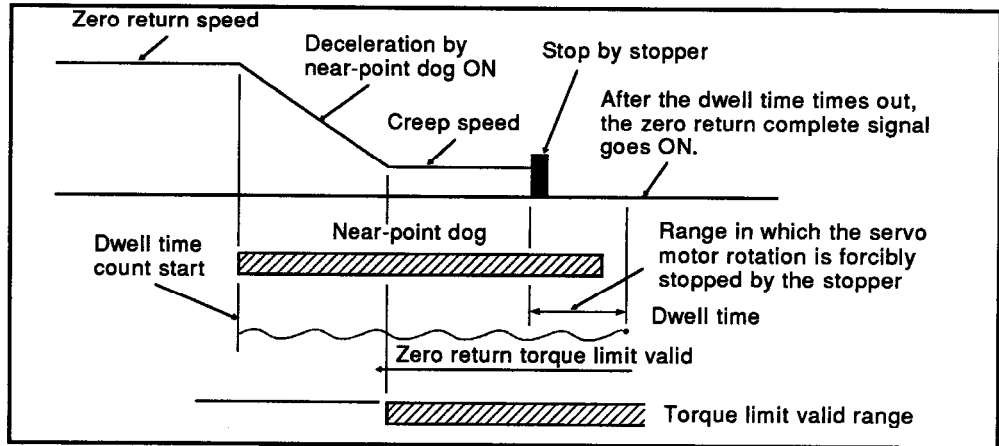

Fig. 3.13-1 Zero Return by Using Stopper Stop (1)

- (c) Mechanical stop (2) (caused by an external stop command)
 

This is the method of stopping by inputting an external stop command when a servo motor interferes with the stopper. (Refer to Fig. 3.13-2.)

Forcibly input a zero-phase signal (stop command) to the zero-phase signal terminal by an external switch after the near-point dog goes ON.

When inputting a zero-phase signal (stop command), the ON/OFF state of the near-point dog is not problem.

After reaching the creep speed, limit the servo motor torque (Section 3.5.2 (7) gives details).

If the servo motor torque is not limited, the servo motor may malfunction when a stopper is hit.

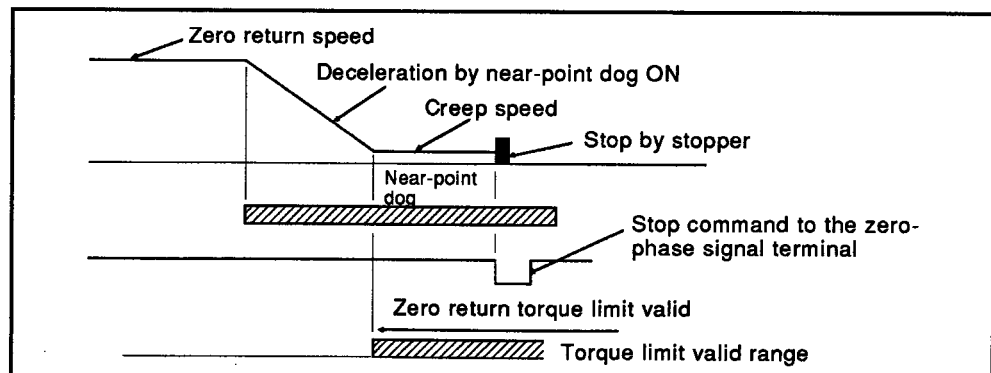
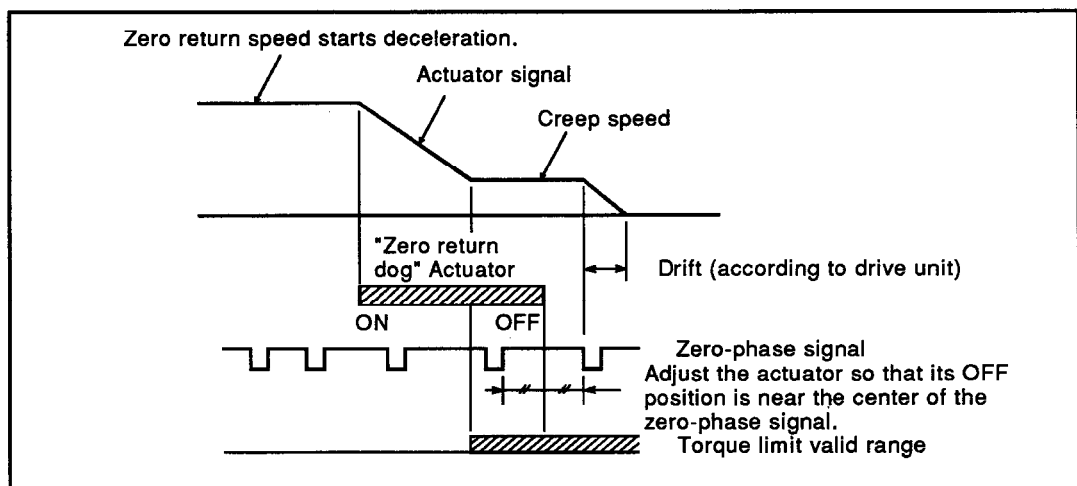

Fig. 3.13-2 Zero Return Using a Stopper

**REMARK**

If a stop signal is input before the speed decelerates to the creep speed, excessive power is delivered to the servo motor and machine system, causing a fault.

- (3) Zero return address
- This address is set as the present value of the home position upon completion of zero return.
  - Set the zero return address to either the upper or lower stroke limit set in the parameters.
- (4) Zero return speed
- Sets the zero return speed. (Refer to Fig. 3.14.)
- (5) Creep speed
- The creep speed is low-speed until stopped after decelerating from the zero return speed by the zero return point dog being ON during zero return. (Refer to Fig. 3.14.)
  - The creep speed varies according to the detected error in the case of zero return by a zero-phase signal and to the size of an impact during collision in the case of zero return by stopper. Therefore, set the creep speed taking the error range and the size of an impact into consideration.



**Fig. 3.14 Zero Return and Creep Speeds**

- (6) Zero return dwell time
- The zero return dwell time is the time until zero return is completed after the near-point dog goes ON during zero return by stopper stop 1).
  - Set the time until stopping by the stopper after the zero return speed decelerates to the creep speed.
  - Even if any value (in the setting range) is input at the time other than stopper stop (1), there is no problem.

(7) Torque limit

This is the set value to limit the torque of a servo motor after reaching the creep speed when zero return.

**POINTS**

- A D-A converter is necessary for torque limit.
- Be sure to set it when doing a zero return operation by stopper stop 2).
- Even if any value (in the setting range) is input when torque is not limited, there is no problem.

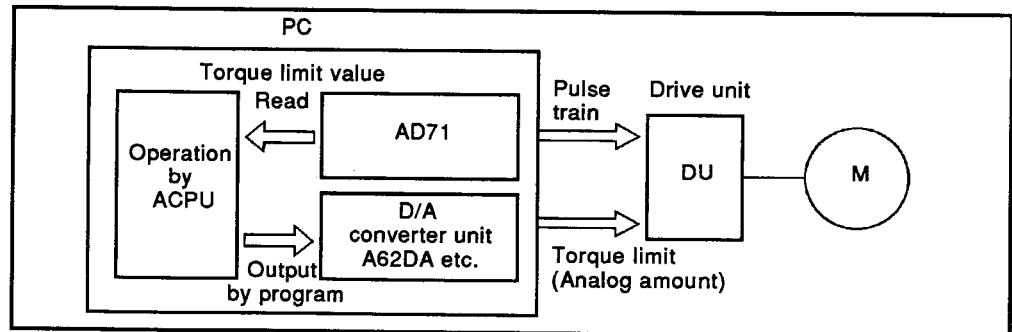

Fig. 3.15 Torque Limit Block Diagram

### 3. SPECIFICATIONS

MELSEC-A

#### 3.5.3 Positioning data

Positioning data is used in the AD71 to execute positioning control (i.e. control other than zero return, inching and jog operation). Refer to Table 3.7. Table 3.7 shows one block of positioning data. 400 blocks can be set for the X and Y axes, respectively.

The block of data used for positioning is dictated by the number set in the positioning start area of the buffer memory.

Positioning data is checked when positioning is started.

**Table 3.7 Positioning Data List**

No.	Item	mm		inch		degree		pulse	
		Setting range	Unit	Setting range	Unit	Setting range	Unit	Setting range	Unit
1	Positioning information	Positioning pattern 00: Positioning terminated 01: Positioning continued 11: Speed changed and positioning then continued							
		Positioning method 0: Absolute 1: Incremental (Valid only when incremental/absolute combination is specified in parameter)							
		Positioning direction 0: Forward direction (address increase) 1: Reverse direction (address decrease) (Valid in incremental mode only)							
		M code 1 to 255: M code 0: M code not specified							
2	Positioning speed	1 to 12000	$\times 10^1$ mm/min	1 to 12000	$\times 1$ inch/min	1 to 12000	$\times 1$ deg/min	1 to 20000	$\times 10^1$ pulse/s
3	Positioning address	0 to $162 \times 10^7$	$\times 10^{-1}$ $\mu$ m	0 to $162 \times 10^7$	$\times 10^{-5}$ inch	0 to $162 \times 10^7$	$\times 10^{-5}$ deg	0 to 16252928	pulse
4	Dwell time	0 to $499(\times 10^1)$ ms							

**POINTS**

- (1) No. 2 to No. 4 can be set from the sequence program.
- (2) Positioning information refers to numbers to be set at peripheral devices.



### 3. SPECIFICATIONS

Data which can be used in the positioning mode is as follows.

Modes Positioning data	Positioning Control	Speed/Positioning Control Switching with AD71S2/A1SD71-S2		Speed Control with AD71S2/A1SD71-S2
		During Speed Control	During Positioning Control	
Positioning pattern	○		Fixed to pattern 00.	
Positioning method	○		○ *1	
Positioning direction	○	○	○	○
M code	○ *2		○ *2	
Positioning speed	○	○	○	○
Positioning address	○		○	
Dwell time	○		○	

○ shows data to be used.

\*1 After switching to positioning control, the present value begins with 0. Therefore, the same control is executed whether the absolute method or the incremental method is used.

\*2 When "M code not used" is set by parameter, this data is not used.

**POINT**

Data without the O symbol in the table is not checked. All values are ignored.

The data to be set as positioning data is explained below.

(1) Positioning information

- Separate the information for the X and Y axes.
- Positioning information consists of 16 bits and includes the following.

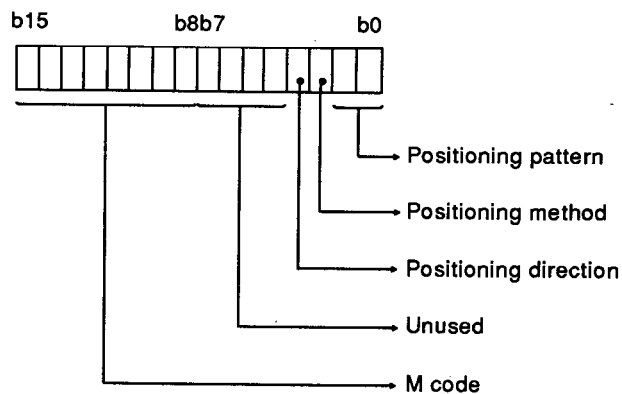

(a) Positioning pattern

Specifies positioning completion in accordance with the positioning data that corresponds to the data number or positioning continuation by the next data number by using the positioning pattern.

The positioning continuation pattern is as follows:

- 1) Positioning is completed in accordance with the specified address, and positioning is continued by the next data number (positioning address).
- 2) Positioning is continued after changing speed at the specified address.

Fig. 3.16 shows how to specify bits in the buffer memory to specify the positioning pattern.

This pattern data is specified by the first two bits of the positioning information.

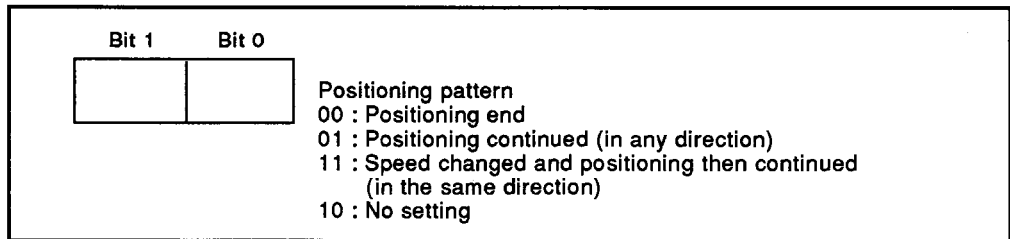

Fig. 3.16 Positioning Pattern

• Positioning end

Drives to the specified address, positioning is complete after the dwell time has elapsed.

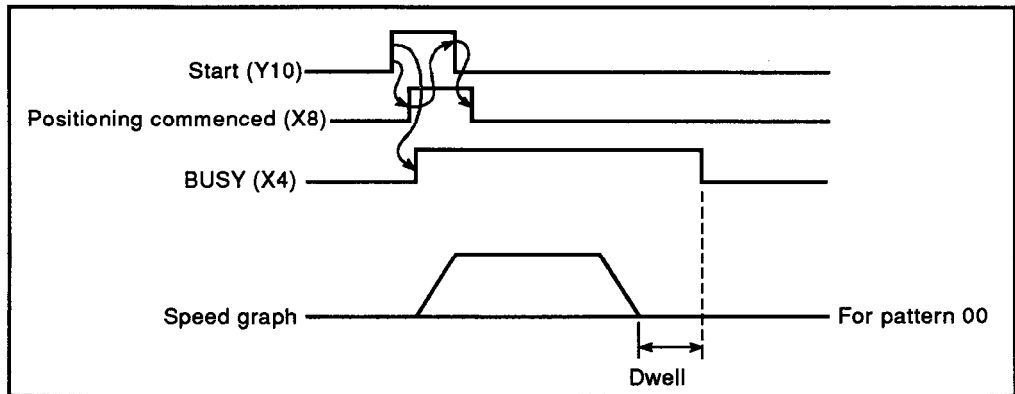

Fig. 3.17 Pattern 00

- Positioning continued

The positions are reached consecutively in the order specified by their data numbers by a single start signal. (The BUSY signal remains on during positioning.)

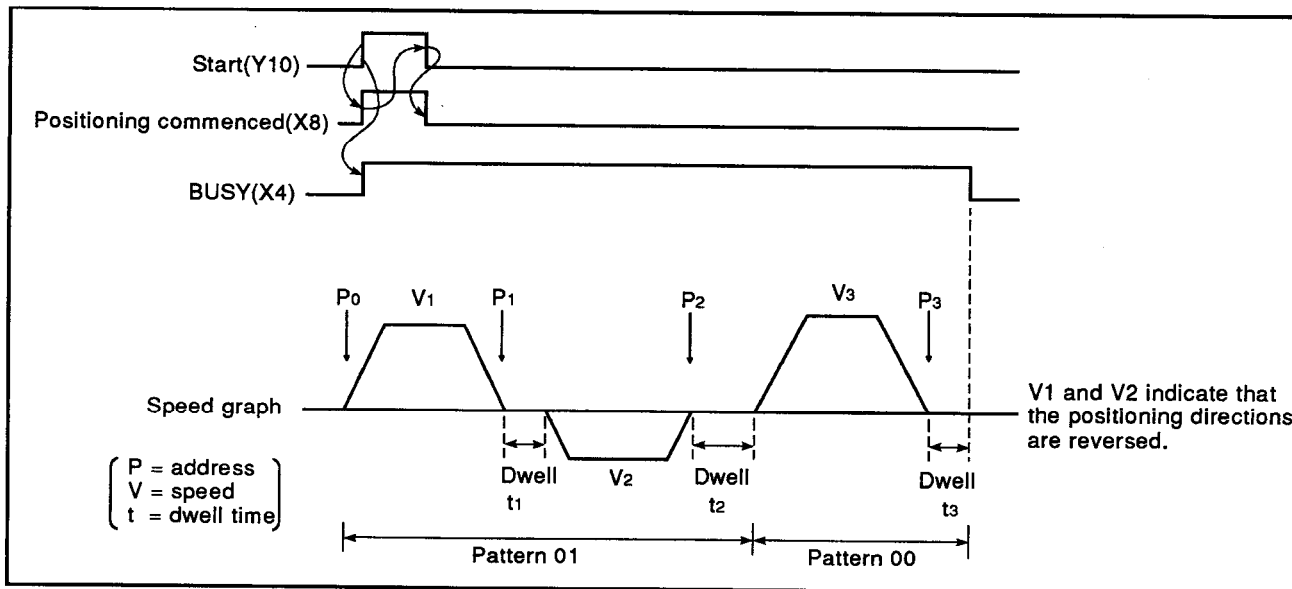

Fig. 3.18 Pattern 01

**POINT**

Pattern 00 should be set for the last position in a series of continuous operations.  
 Pattern 01 may be set for interpolation positioning. In this case, the patterns for the X and Y axes should be the same. The X and Y axis patterns are checked before operation and any error will stop positioning.

- Positioning continues with speed change

The positions are reached consecutively in the order specified by their data numbers by a single start signal. During positioning, the speed may be changed but the direction remains the same. (Refer to Fig. 3.19.)

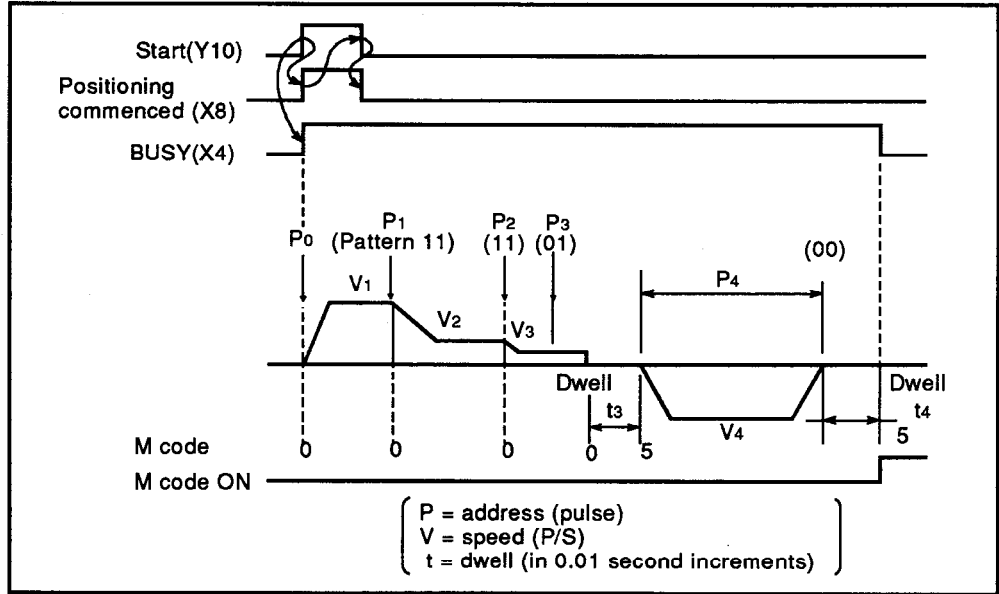

Fig. 3.19 Pattern 11

Table 3.8 shows the positioning data for Fig. 3.19. The following conditions apply:

Hypothetical conditions { M code ON/OFF timing : AFTER mode  
 Incremental/absolute method : Incremental and absolute combined

Table 3.8 Positioning Data

	Data No.	Pattern	Speed	Address	Dwell	Method	M code
X axis	100	11	V <sub>1</sub>	P <sub>1</sub>	-	Abs.	0
	101	11	V <sub>2</sub>	P <sub>2</sub>	-	Abs.	0
	102	01	V <sub>3</sub>	P <sub>3</sub>	t <sub>3</sub>	Abs.	0
	103	00	V <sub>4</sub>	P <sub>4</sub>	t <sub>4</sub>	Inc.	5
	104						
	105						
	106						
	107						
108							

In the method column, Abs. indicates absolute method and Inc. incremental method.

**POINTS**

- (1) For continuous positioning, pattern 11 should not be used more than nine times consecutively. Where a large number of consecutive 11 patterns are being used, they must be broken down by placing 01 pattern data every nine 11 patterns. (e.g. pattern 11 = 9 times, pattern 01 = 1 time, pattern 11 = 9 times, pattern 00 = 1 time).
- (2) Always set pattern 00 in the final data block.
- (3) While pattern 11 is continuing, the direction of movement and the positioning method should remain unchanged, only after pattern 01 or 00 may these be changed. If the speed is changed after deceleration has started, the new speed is ignored and, if the M code has been set in WITH mode, the "M code ON" signal is not given.
- (4) During positioning using pattern 11, dwell time data and M code will be ignored.
- (5) Interpolation positioning cannot be specified when pattern 11 is being used.
- (6) Pattern 11 and pattern 01 cannot be used in the speed/positioning control switching mode when an AD71S2 or A1SD71-S2 is used. If positioning patterns 11 and 01 are set during positioning control in the speed/positioning control switching mode, all positioning patterns will be executed as pattern 00.

Example 1) When positioning pattern 11 is set in the speed/positioning control switching mode

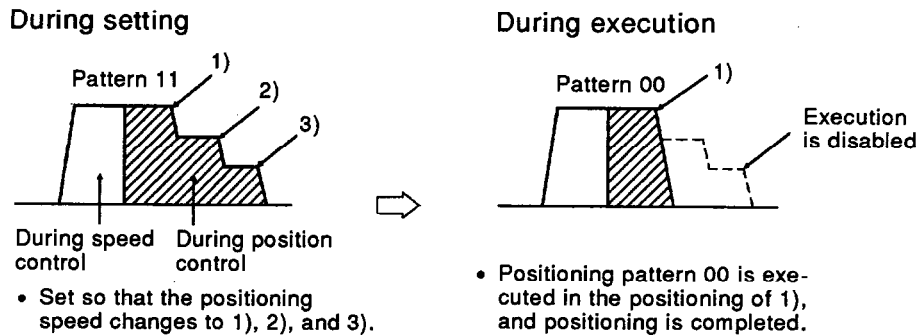

Example 2) When positioning pattern 01 is set in the speed/positioning control switching mode

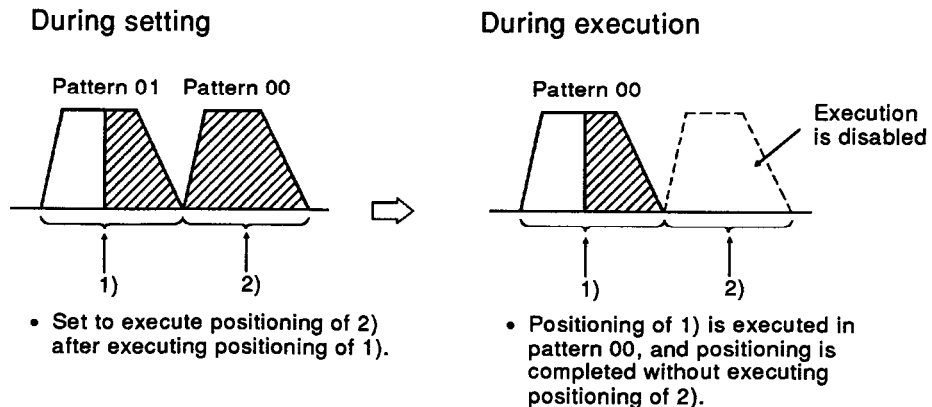

(b) Positioning methods

The positioning method specified in positioning data becomes valid only when a parameter positioning method was specified to use both incremental and absolute mode positioning.

(If the parameter positioning method is not specified to use both incremental and absolute mode positioning, the specification of the positioning method in positioning data is ignored, and the positioning method follows the setting in the parameter.)

**POINT**

While pattern 11 is continuous, positioning methods cannot be changed.

When use of both incremental and absolute mode positioning is specified, positioning methods can be changed after pattern 00 or pattern 01.

(c) Positioning direction

- For incremental mode positioning, the direction of travel relative to the previous address must be specified. (0 specifies forward, increasing address numbers and 1 specifies reverse, decreasing address numbers.)

In absolute mode, the positioning direction is ignored.

- Set the operation direction when starting positioning in the speed/positioning control switching mode and the speed control mode.  
(During JOG operations, setting to 0 specifies forward, increasing address numbers and 1 specifies reverse, decreasing address numbers.)

(d) M code

Specifies an "M" code relevant to that position address. (range: 0 to 255)

The code should be set to 0 if it is not required.

During interpolation positioning, M codes are given individually for the X and Y axes. (X-axis M code, buffer address = 46. Y-axis M code, buffer address = 346.)

(2) Positioning speed

Specifies the speed at which the next position is to be approached.

Set the positioning speed to within the speed limit value range of the parameter.

**POINT**

Before operation, the parameter speed limit is checked and if the positioning speed exceeds the speed limit value, the parameter speed limit value is used.

Positioning speed for linear interpolation

During linear interpolation positioning, the speed set for the axis with the furthest to travel takes precedence and the speed of the other axis is derived as follows.

(Short travel axis speed)

$$= (\text{long travel axis speed}) \times \frac{(\text{short travel distance})}{(\text{long travel distance})}$$

An example of this is given in Fig. 3.20 which uses the following data:

	X Axis	Y Axis
Parameter set value : speed limit value	20 kPPS	50 kPPS
Positioning data set value : positioning speed	20 kPPS	50 kPPS

To move from point A (address 0, 0) to point B (100 kpulse, 200 kpulse), X-axis travel is less than Y-axis travel so  $V_y = 50 \text{ kPPS}$  has precedence.

$$\text{X-axis positioning speed} = 50 \times \frac{100}{200} = 25 \text{ kPPS}$$

(This speed exceeds the speed limit value which is ignored in this case.)

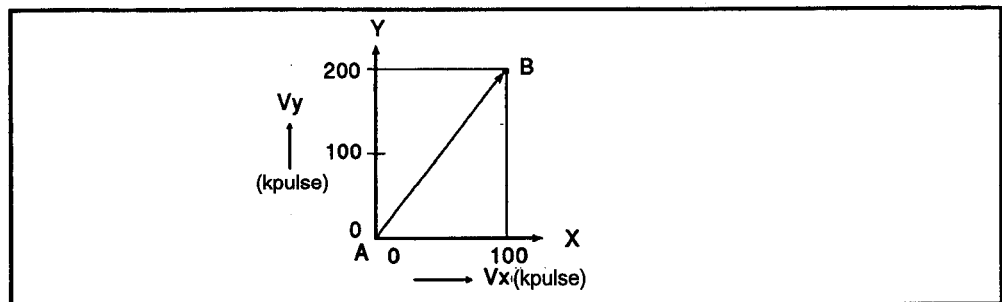

Fig. 3.20 Linear Interpolation

**POINT**

In the case of linear interpolation, the setting speed of the axis whose travel distance is smaller is ignored.

Therefore, when the combination of travel distance and speed differs greatly between the X and Y axes, the travel speed of either X or Y may be larger than the setting speed. (The speed limit value is ignored.)

In the case of linear interpolation, Mitsubishi recommends setting the same positioning speed and speed limit value to both the X and Y axes.

**REMARK**

Positioning speeds are multiplied by 6.1 (pulse/s).

For example, when a positioning speed is 200 (pulse/s), the maximum speed to be output from AD71 is as follows:

$$200 = 6.1 \times n \dots n = 32.7868 \dots$$

Therefore, the maximum speed is  $6.1 \times 32 = 195.2$  (pulse/s).

(3) Positioning address

Set the positioning address in accordance with the positioning method.

- When using the incremental method, set the travel distance in the position control mode. When using the absolute method, set the target position.
- Set the travel distance after receiving a control switching signal in the speed/positioning control switching mode.

(4) Dwell time

The dwell time is the period of time indicated in Fig. 3.21 below.

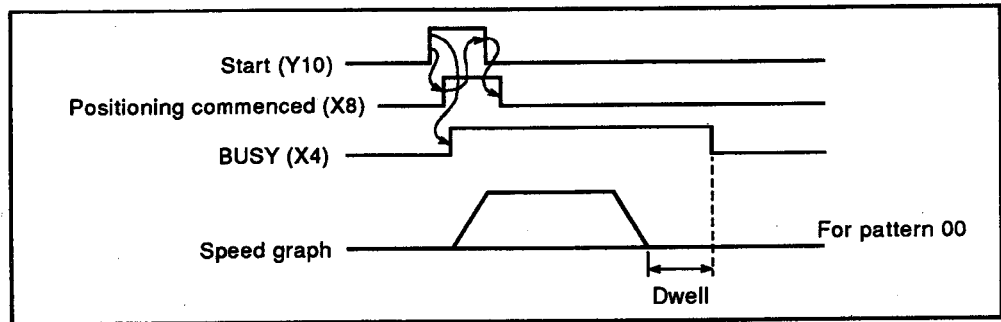

**Fig. 3.21 Pattern 00**

During interpolation positioning, the longer dwell time value is valid irrespective of the distance travelled (e.g. if X axis = 1 s and Y axis= 1.5 s, 1.5 s is valid.)



#### 3.5.4 Positioning mode of AD71S2/A1SD71-S2

An AD71S2/A1SD71-S2 can be operated in the three following positioning modes:

- Positioning control mode ..... Positioning functions are the same as for an AD71(S1/S7)/A1SD71-S7.
- Speed/positioning control ..... The AD71S2/A1SD71-S2 operates in the speed control mode by a one-time start signal. Then, when an external control mode switching signal is input, it switches to the positioning control mode.
- Speed control mode ..... The AD71S2/A1SD71-S2 continues operating until a stop signal goes ON.

Set the positioning mode of the AD71S2/A1SD71-S2 in the parameter item No. 18. (Refer to Section 3.5.1, Section 3.6.4.)

- 0: Positioning control mode
- 1: Speed/positioning switching control mode
- 2: Speed control mode

- (1) Positioning control mode  
Section 3.5.3 gives details.

(2) Speed/positioning control switching mode

The AD71 operates in the speed control mode by a one-time start signal. Then, when a control mode switching signal is input while inputting the external enable signal, it is switched to the positioning control mode.

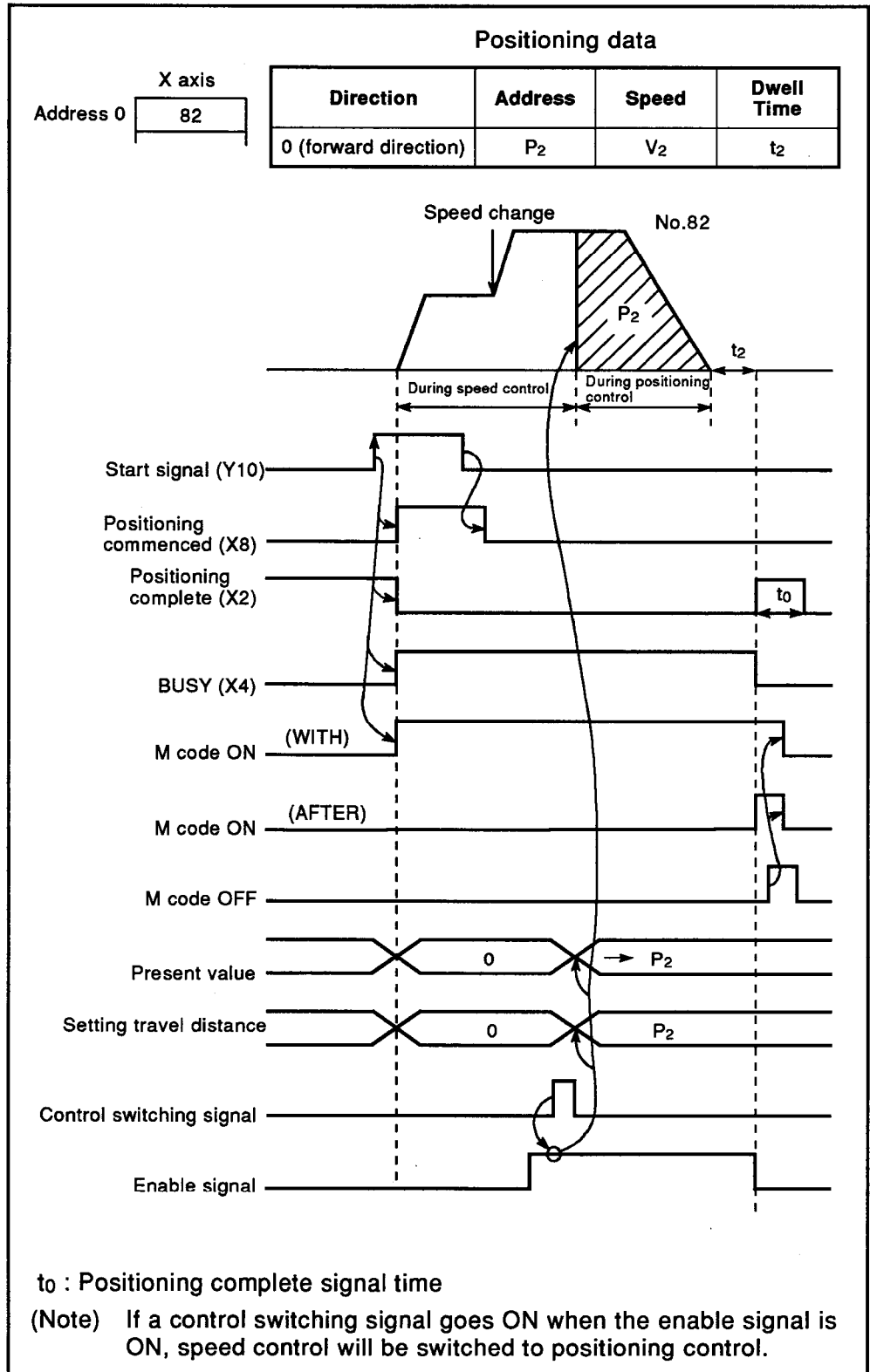
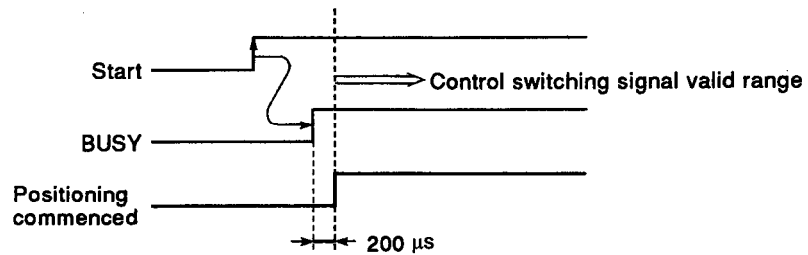

Fig. 3.22 Switch Timing in the Speed/Positioning Control Switching Mode

**POINTS**

- Interpolation operation is disabled.
- When it is switched to positioning control, an error compensation is executed.
- The present value is set to "0" when starting. Then, the present value begins to change when positioning control is started.  
If a restart is executed in positioning control, the present value continues from the stop address.  
If a restart is executed in speed control, the pulse outputs from "0". The present value is represented as follows: The positioning control starting point of a present value is "0". The positioning control direction of a present value is an address increase direction, and it is represented as an absolute value (absolute address).
- The maximum number of output pulses during speed control is about 16,000,000 pulse.  
After outputting the maximum number of output pulses, pulse output is automatically stopped.  
The switching signal after starting automatic deceleration in speed control or after starting deceleration by a stop signal input becomes invalid.
- When executing restart, the start data number must be the same as the execution data number when it stops halfway.
- If a control switching signal is received when traveling within backlash, the remaining amount of travel distance will fluctuate.
- After a start completion signal goes ON when a BUSY signal is ON, the control switching signal becomes valid. (It becomes invalid even if a control switching signal is input after that.)



- Positioning error in the speed/positioning control switching mode  
An external control switching signal is received during speed output and is switched to positioning control in the speed/positioning control switching mode.  
However, since a little time is needed for the OS to complete the switching to positioning control after receiving the signal, the number of pulses output during switching becomes a positioning error.

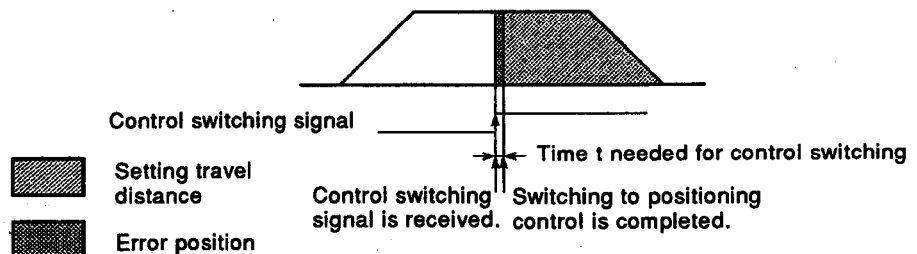

If the time needed for control switching is  $t$  msec, the position error is calculated

$$\text{Position error (pulse)} = \left( \frac{\text{Output speed (pulse/s)}}{10^6} \times t \right) \pm 1 \left[ \begin{array}{l} + \\ - \end{array} \text{Deviation counter pulses} \right]$$

Because the time ( $t = \text{max. } 1 \text{ ms}$ ) needed for the control change differs with each product, always take

(a) Changing a positioning address (travel distance)

If data is written in a travel distance change area (buffer memory address, X axis: addresses 203, 204 and Y axis: addresses 503 and 504) before a control switching signal is input, a travel distance can be changed during BUSY.

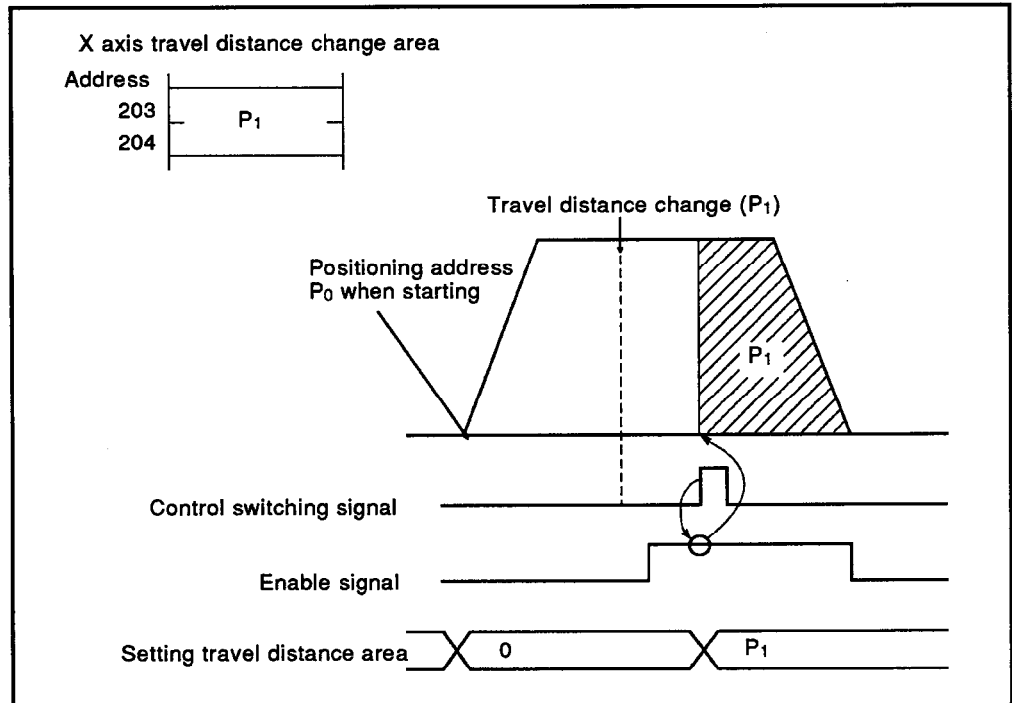

Fig. 3.23 Positioning Address Switch Timing

POINTS

- When data is written in a travel distance change area from a PC CPU with a sequence program, the OS recognizes a travel distance request.
- A travel distance change is valid until a control switch signal is input during BUSY in the speed/positioning control switching mode.
- If data is not written to the travel distance change area, a positioning address that corresponds to the data number specified when starting is used as the travel distance.

(b) Temporary stop and restart

When a stop signal is input, and processing stops after inputting a control switching signal, and the remaining travel distance is output, processing will stop if "1" is set to a restart setting area (X axis: 205 and Y axis: 505) to start.

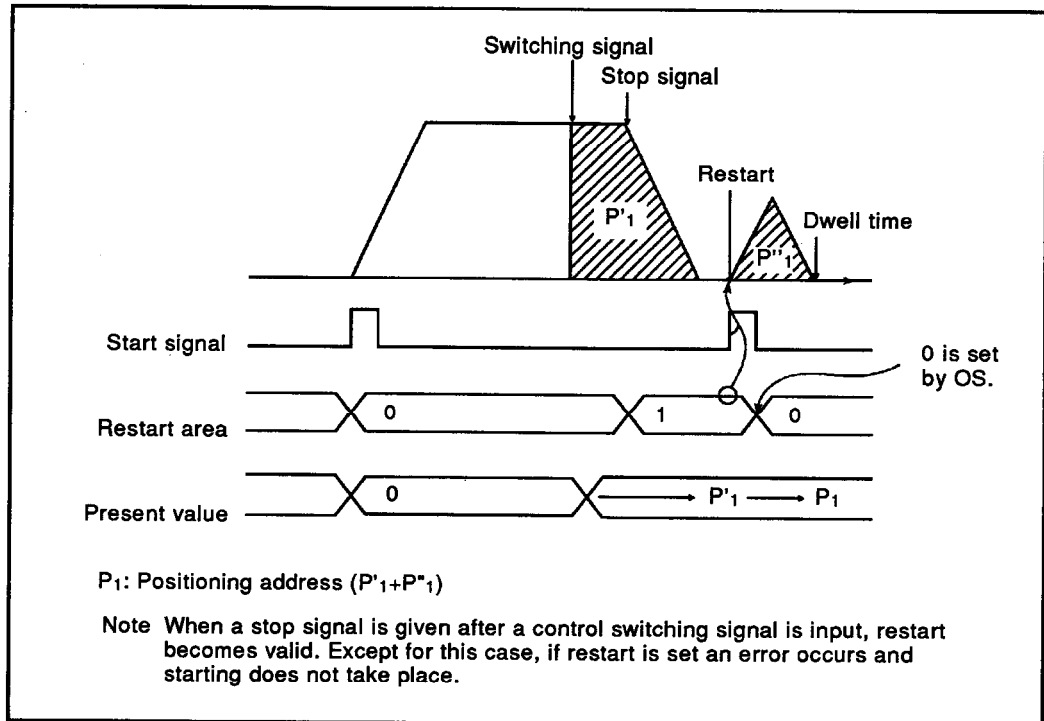

Fig. 3.24 Timing of Temporary Stops and Restarts

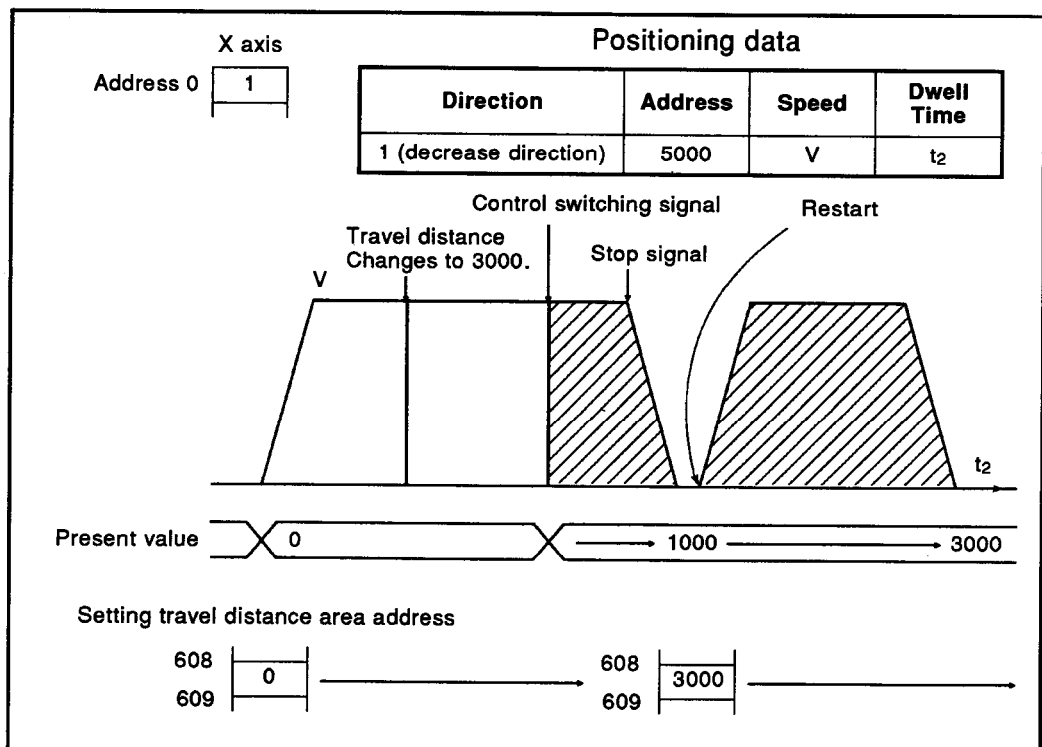

Fig. 3.25 Example of a Temporary Stop and Restart

#### POINTS

- The following data is checked when restarting.
  - 1) Start data number (same as the execution number when stopping)
  - 2) Dwell time
  - 3) Positioning speed
- The travel direction when restarting is as follows:
  - 1) Present value < setting travel distance ..... Direction is the same as before stop (address increase)
  - 2) Present value > setting travel distance ..... Direction is the same as before stop (address decrease)

Note) When the present value is changed

(Positioning data positioning direction is not used.)

- Positioning data positioning address is not used.  
The travel distance is decided by the present value and the setting travel distance.  
Travel distance = | Setting travel distance – present value |
- M code is set again.
- When the M code is used in the WITH mode, the M code ON signal does not go ON.  
When the AFTER mode is used, the M code goes ON when positioning is completed.

(3) Speed control mode

The operation is started by a one-time start signal and processing continues until a stop signal comes in.

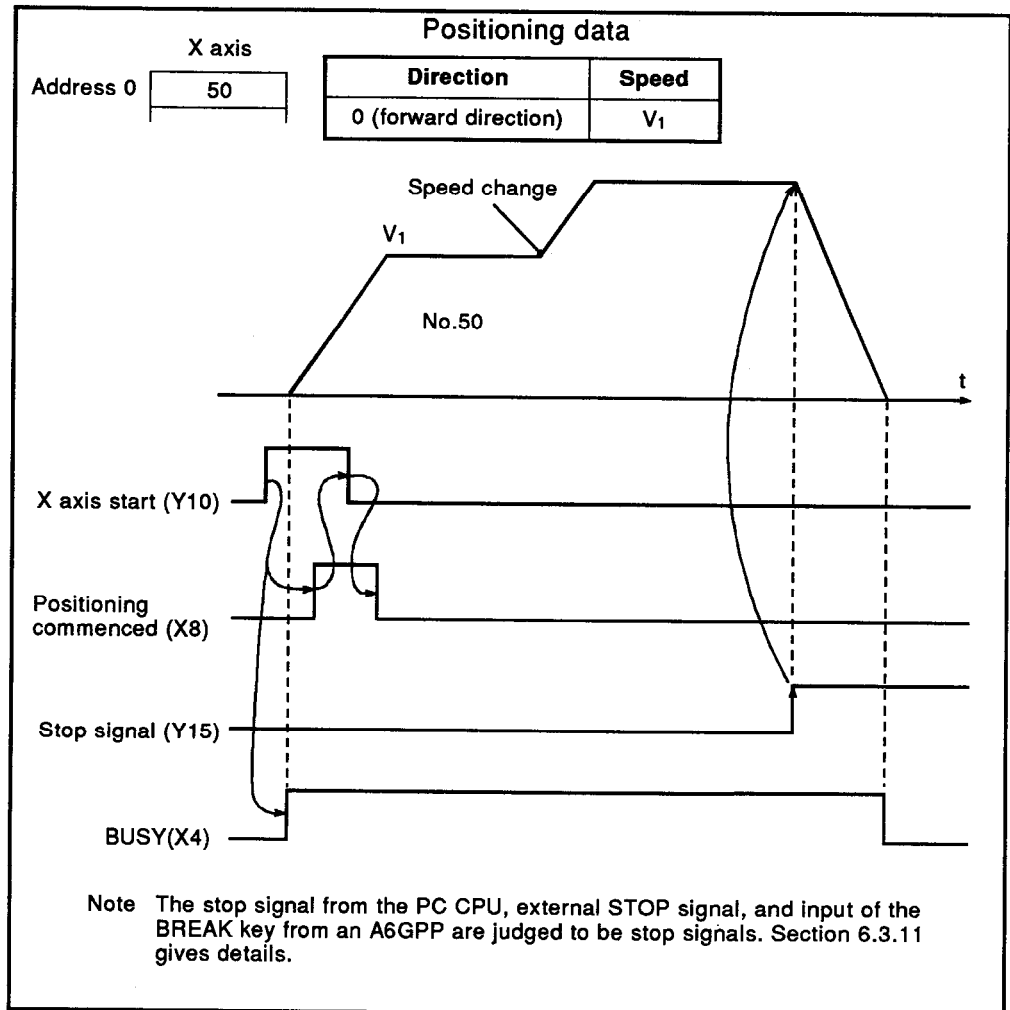

Fig. 3.26 Speed Control Mode Setting Example

**POINTS**

- Processing continues until a stop signal is received. If the stop factors in Section 6.3.11 do not occur, an automatic stop will not occur.
- The present value is set to 0 when starting and does not change during operations.
- The positioning complete signal M code ON signal does not go ON.
- The speed can be changed.
- If a stop command is received during traveling within backlash, OS controls it so that processing stops after traveling the backlash amount backlash.

Interpolation operations in the speed control mode

Interpolation operations are executed to match the speed acceleration/deceleration timing of the two axes.

The positioning axis whose positioning speed is faster becomes the priority axis (master axis), and the speed is adjusted in accordance with the speed acceleration/deceleration curve of the axis.

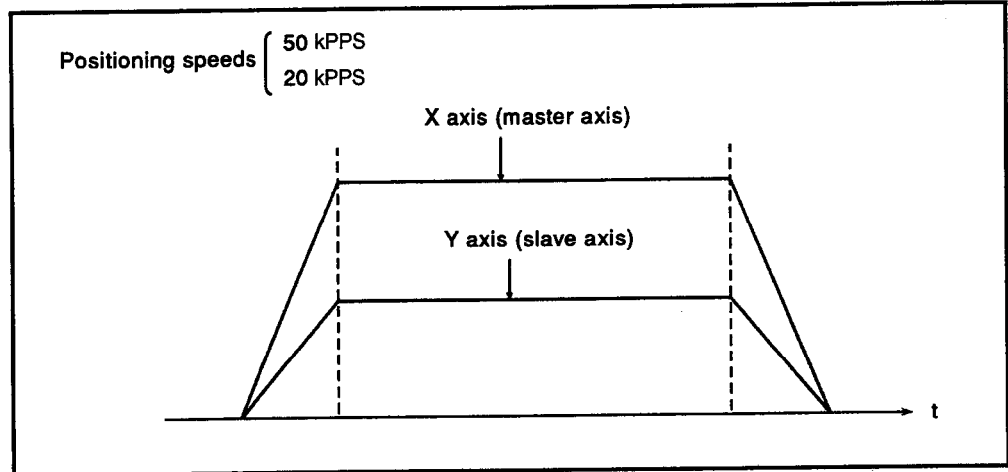

Fig. 3.27 Example of a Master Axis During Interpolation



#### 3.6 Buffer Memory

The AD71 incorporates a buffer memory (with a battery back-up function) for data communication with the PC CPU.

This memory stores the data shown in Fig. 3.28, with which the AD71 controls positioning.

The following approaches are available to read and write data shown in Fig. 3.28.

Data can be read from the buffer memory as follows:

- Reading data using the sequence program
- Reading data using the peripheral device

One word (16 bit) or two word data can be read by using the buffer read application instructions.

Data can be read in the various modes of a peripheral device.

For details, refer to the SW0GP-A1SD71P Operating Manual.

Data can be written to the buffer memory as follows.

(The writing of data may be restricted depending on the status of the AD71. General write conditions are shown in Fig. 3.28. For further details, refer to Section 3.6.1 to 3.6.5.)

- Writing data from the sequence program
- Writing data from the peripheral device

One word (16 bit) or two word data can be written by using the buffer write application instructions.

Data can be written by storing data to a memory area in the A6GPP and transferring data in blocks from the A6GPP to the AD71 buffer memory.

The AD71TU writes data directly to the buffer memory in units of one word (16 bits) or two words.

An additional function allows individual pieces of positioning data to be written to the buffer memory if the AD71 is busy. For details, refer to the SW0GP-AD71P Operating Manual, or the AD71TU Operating Manual.

#### **REMARK**

For buffer memory access instructions, refer to Chapter 6 "Programming."

#### **POINT**

Among the special function module processings, access from the PLC CPU is processed with priority. Therefore, frequent access from the PLC CPU to the special function module buffer memory will not only increase the scan time of the PLC CPU but will also cause a delay in the special function module processings. Access from the PLC CPU to the buffer memory using the FROM/TO instructions, etc. should be made only when necessary.

Address	Description	Source of Data	
		Sequence Program	SW0GP-AD71P or AD71TU
0 to 205	X-axis positioning start data	Depends on data	Write enabled when both X-axis and Y-axis BUSY signals are off.
300 to 505	Y-axis positioning start data	—	—
512 to 767	For OS	Depends on data	Write enabled when both X-axis and Y-axis BUSY signals are off.
768 to 3871		Unused	—
3872 to 4271	Positioning information	OS RAM. Writing here is not allowed.(Refer to Section 3.6.2)	Write disabled
4272 to 4671	Positioning speed	Unused	—
4672 to 5071	Dwell time	X axis positioning data area described in Section 3.6.3 (Maximum 400 positions)  Data format as follows: Positioning information : 2 bytes (16 bits) Positioning speed : 2 bytes (16 bits) Dwell time: 2 bytes (16 bits) Positioning address : 4 bytes (32 bits)	Write enabled at any time
5072 to 5871	Positioning address		
5872 to 6271	Positioning information		
6272 to 6671	Positioning speed	Y axis positioning data area described in Section 3.6.3 (Maximum 400 positions) Data format as for X axis.	Write enabled at any time
6672 to 7071	Dwell time		
7072 to 7871	Positioning address		
7872 to 7889	X-axis parameters	Parameter area explained in Section 3.6.4 (X axis)	Write only enabled when PC ready signal is off
7892 to 7908	Y-axis parameters		
7912 to 7918	X-axis zero return data	Zero return data area described in Section 3.6.5 (X axis)	Write only enabled when PC ready signal is off
7922 to 7928	Y-axis zero return data	Zero return data area described in Section 3.6.5 (Y axis)	

The above data may be read at any time.  
Addresses are expressed in decimal (1 address = 2 bytes (16 bits))

Fig. 3.28 Buffer Memory Map

### 3. SPECIFICATIONS

#### 3.6.1 Positioning start data

The positioning start data area is shown in Fig. 3.29. The arrangement of the data is the same for both X and Y axes, only addresses are different.

**POINT**

Both the X-axis and Y-axis BUSY signals must be off to write this data into the AD71 from the A6GPP.  
 Since the conditions for writing positioning start data using a sequence program depend on the data type, they are explained in the text.

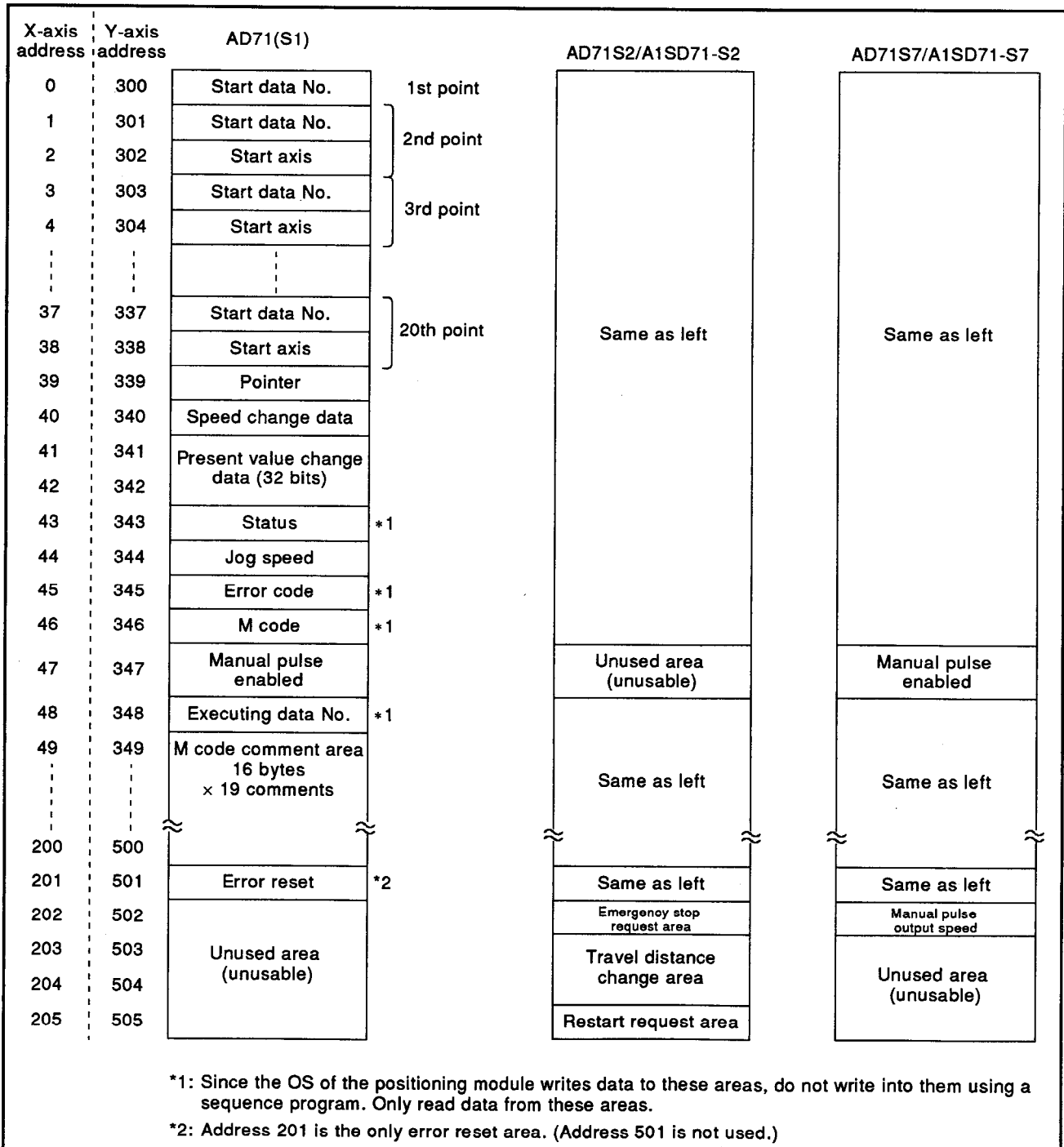

Fig. 3.29 Positioning Start Data Area

### 3. SPECIFICATIONS

#### 3.6.1(1) Start data number area (X axis :address 0, Y axis :address 300)

- Positioning is executed sequentially by data number using a one-time start signal in the positioning control mode, and positioning operations are completed by positioning END of positioning pattern 00. To execute the above series of positioning operations continuously, the first data number (start data number) and the start axis of the positioning operation series are registered. This area is called a start data number area.
- The start data number and pointer of the 20th point are valid in the positioning control mode.
- Only the start data number of the first point is valid in the speed/positioning control switching mode and speed control mode when an AD71S2 or A1SD71-S2 is used. The pointer value is invalid.

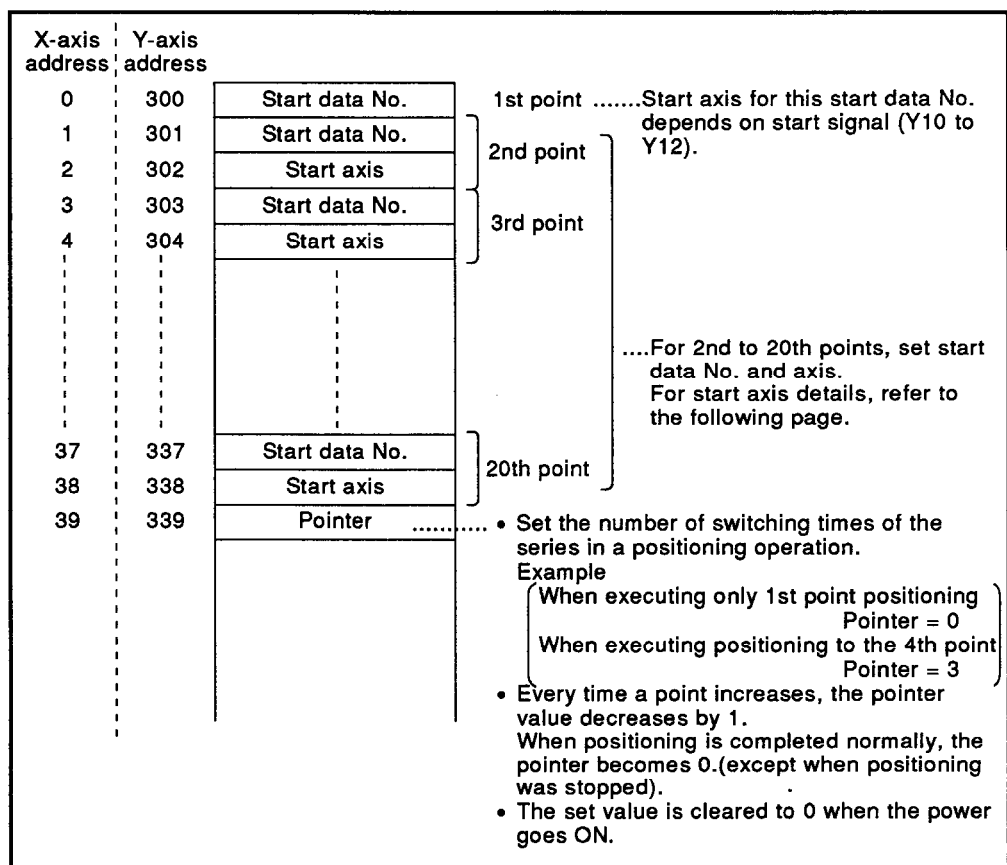

Fig. 3.30 Start Data Number Area

**POINTS**

- When positioning of the start data number of the 20th point is completed, positioning is completed even if the value of a pointer is not 0 (however, an error code is set).
- The BUSY signal remains ON during switching to the next point after positioning of the 1st point has been completed.

(a) Start axis area details

Use the two least significant bits of these addresses to define the start axis. (See Fig. 3.31.)

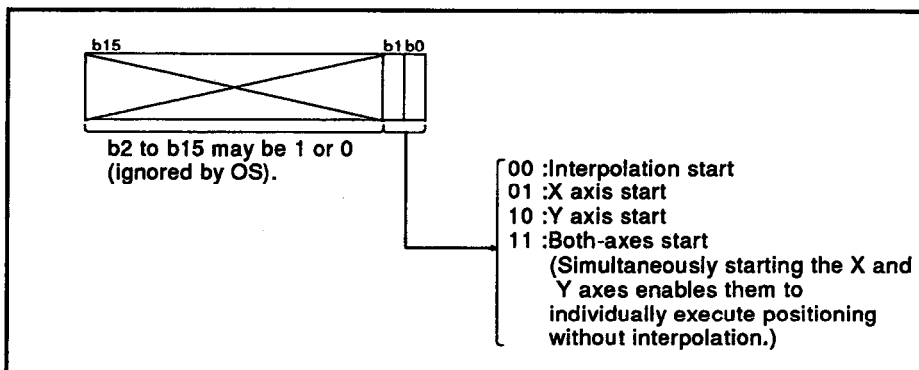

Fig. 3.31 Start Axis Area

The following occurs if both axes are started and an error is found in one:

- 1) both axes stop if the error has occurred between consecutive positions.
- 2) only the axis with the error stops if the error occurred after both axes have started.

(b) Data setting precautions

- 1) If the start axis is set to an interpolation start (00) or both-axes start (11) and the other axis is busy with other than positioning, an error occurs and the positioning process of the original axis is stopped. (Refer to Fig. 3.35.)

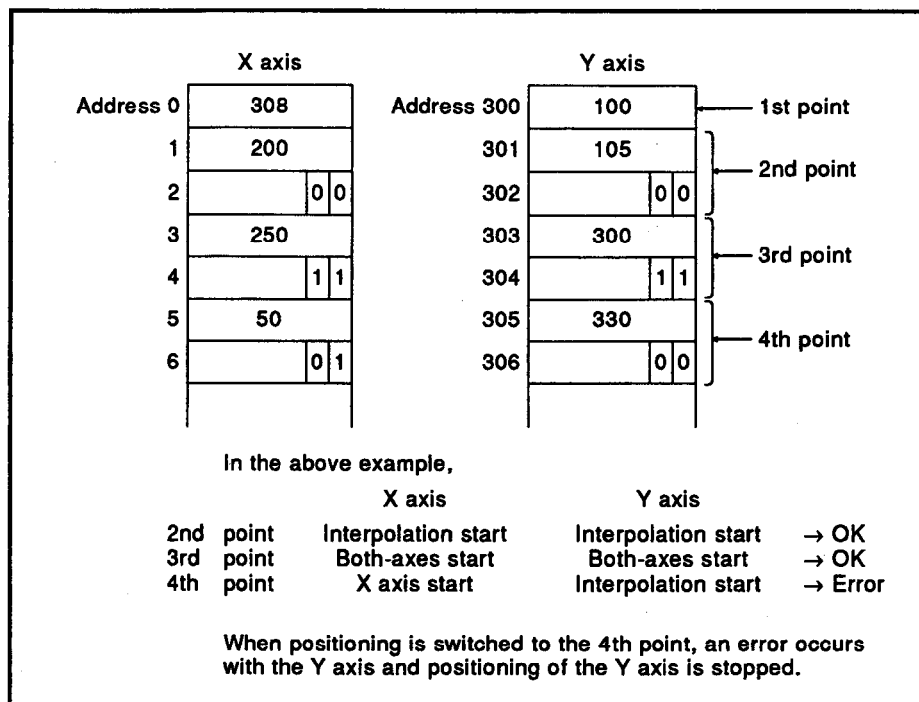

Fig. 3.32 Start Data Example 1

- 2) If the start axis in the X-axis start data number area is set at the Y axis (10), the point data is ignored (positioning is not executed) and the next point is processed. (Refer to Fig. 3.33.)  
 If the start axis in the Y-axis start data number area is set at the X axis (01), the next point is processed.

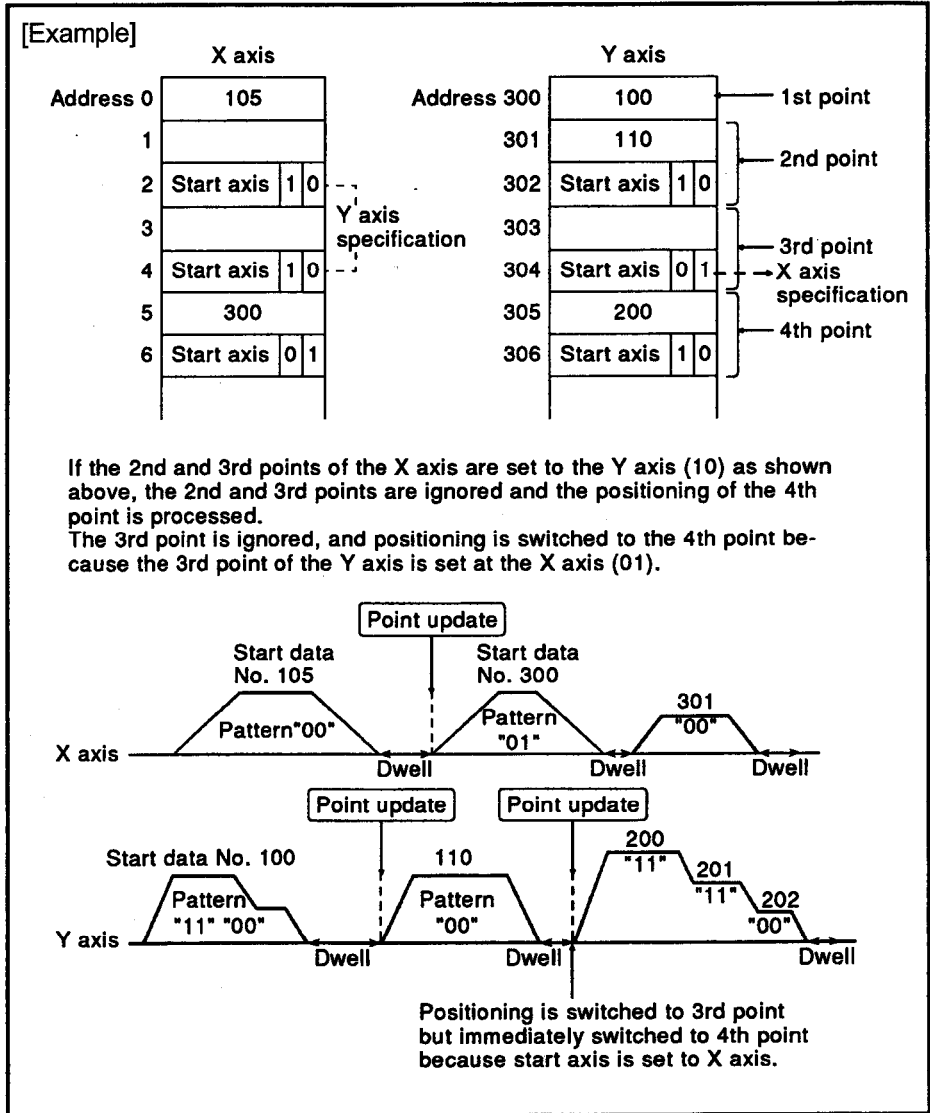

Fig. 3.33 Start Data Example 2

- 3) When the start axis is set to interpolation start (00) or both-axes start (11) and the other axis is not set to BUSY, the other axis starts positioning automatically using the start data number set at the point that is the same as its own axis (refer to Fig. 3.34).  
If the M code ON signal of the other axis goes ON at this time, an error occurs.

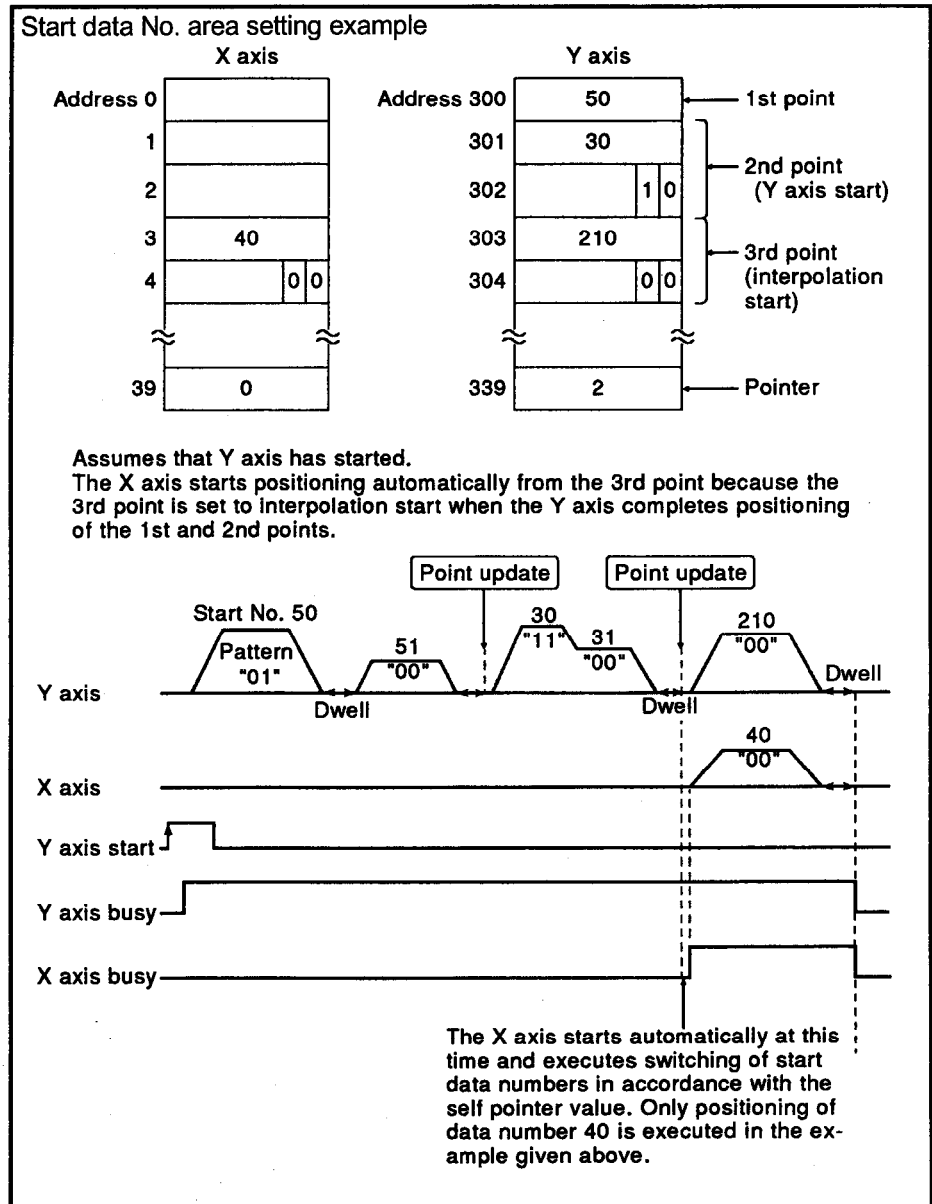

Fig. 3.34 Start Data Example 3

- 4) If the start axis is set to an interpolation start (00) or both-axes start (11) and the other axis is busy with other than positioning, an error occurs and the positioning process of the original axis is stopped.  
(Refer to Fig. 3.35.)

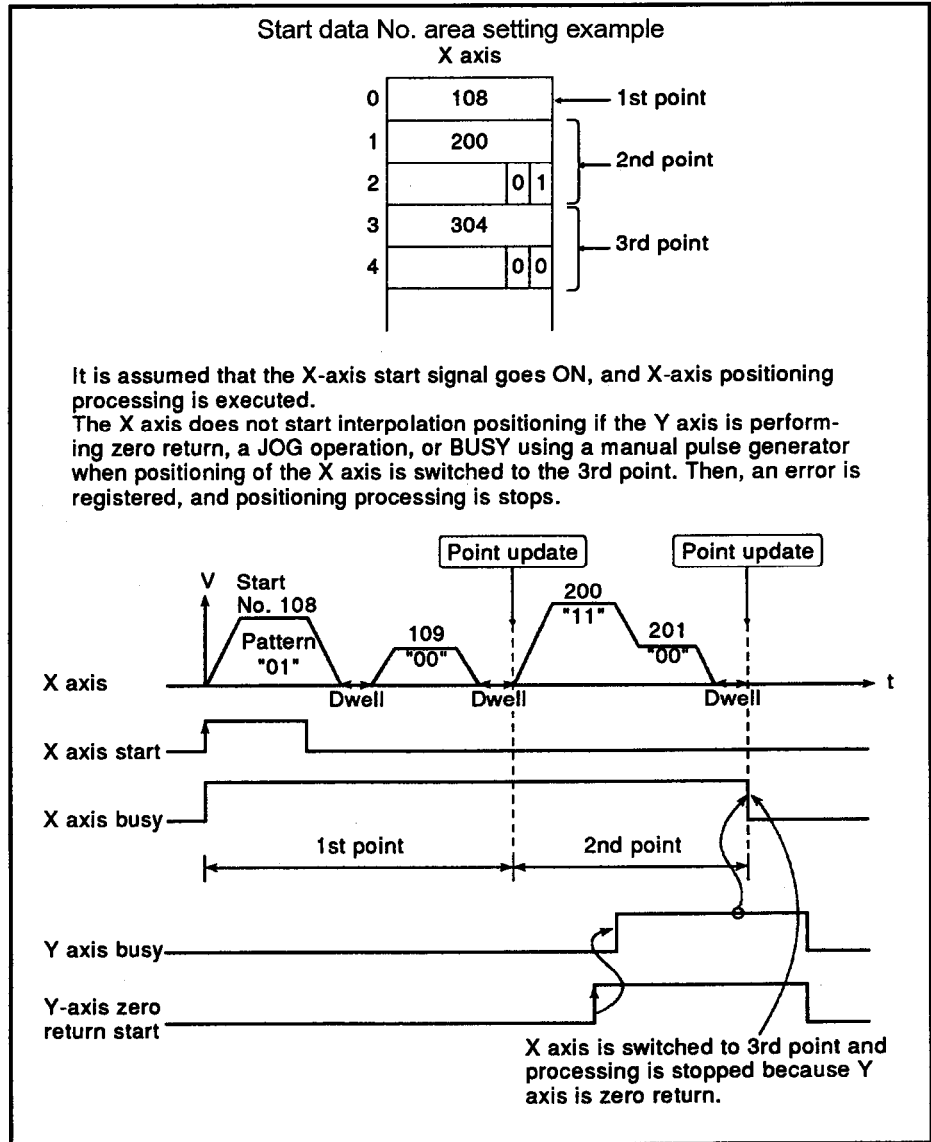

Fig. 3.35 Start Data Example 4



### 3. SPECIFICATIONS

### MELSEC-A

5) In a situation where interpolation (00) or independent (11) start has been defined at one axis and the other axis is still positioning, processing will vary as described below.

- An axis will wait for the other to finish its current process or for its busy signal to turn off. This is illustrated in Fig. 3.36 below.

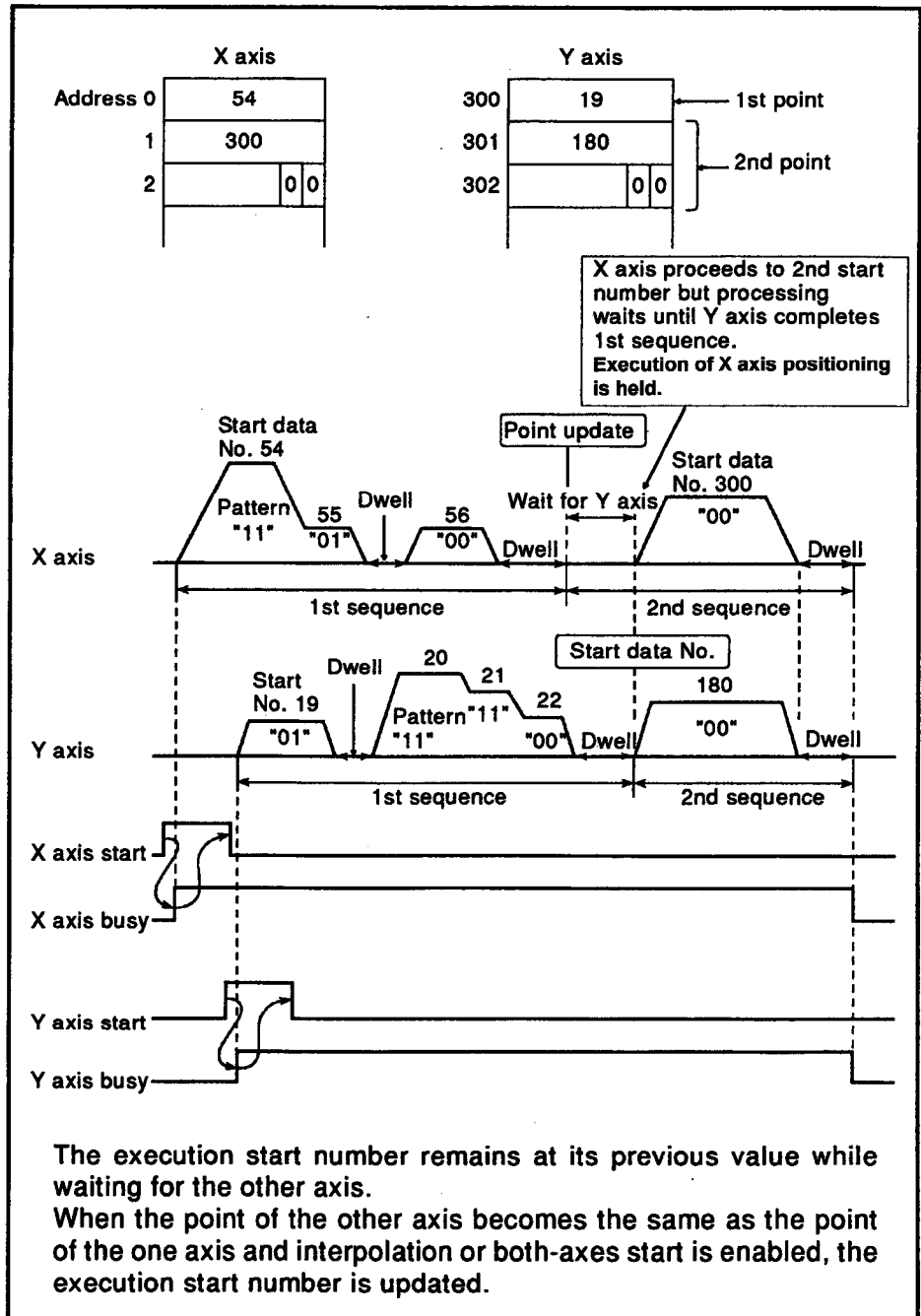

Fig. 3.36 Start Data Example 5

### 3. SPECIFICATIONS

### MELSEC-A

- Processing will stop if one axis proceeds ahead of the other and dual axis processing is called. See Fig. 3.37.

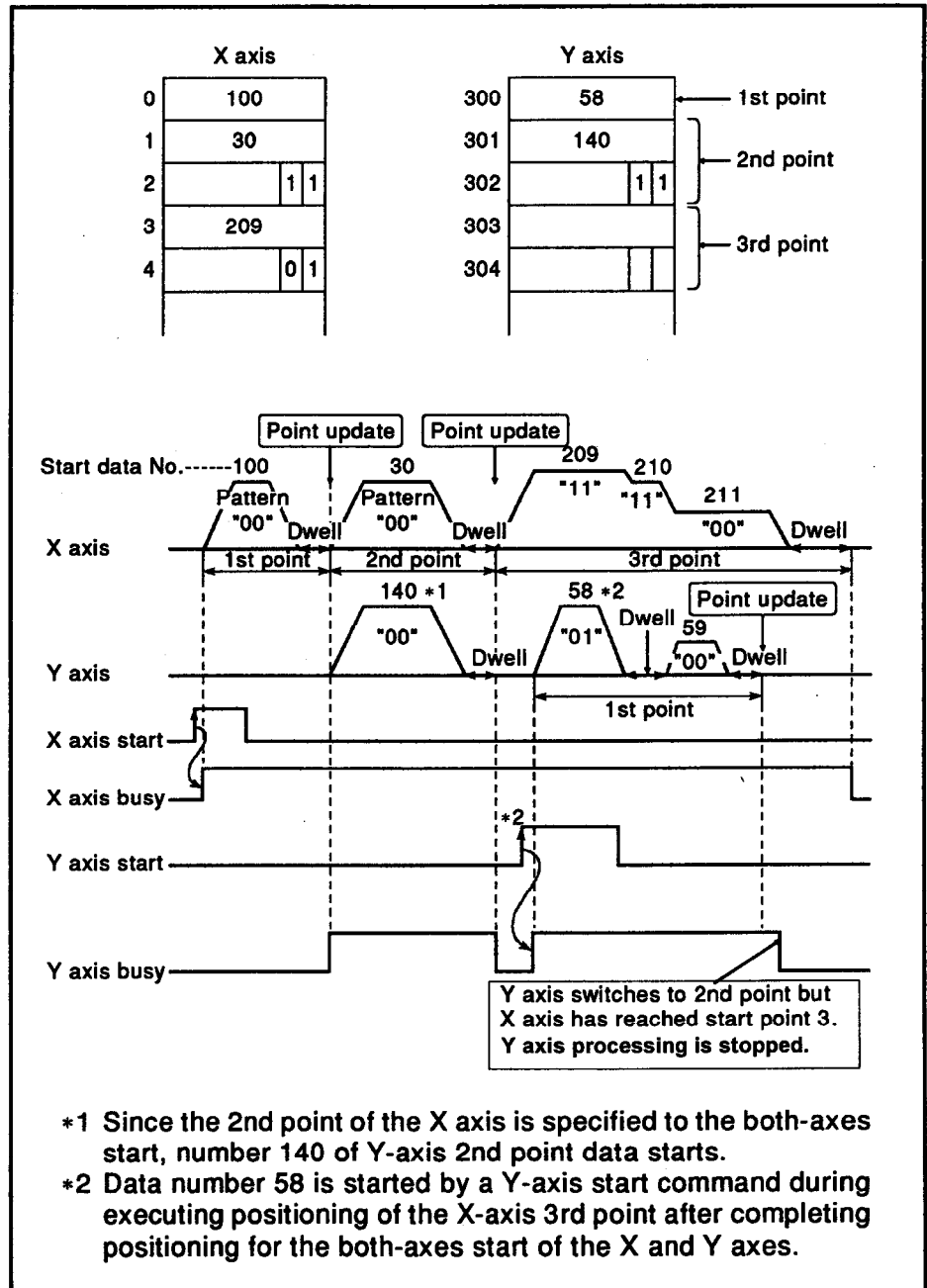

Fig. 3.37 Start Data Example 6

### 3. SPECIFICATIONS

### MELSEC-A

#### 3.6.1 (2) Speed change data area (X-axis: address 40; Y-axis: address 340)

To make a forced speed change using a sequence program during positioning by the AD71, operation by the AD71S2 or A1SD71-S2 in the speed control mode, JOG operation or zero return, write speed data (within the range specified in Table 3.7) to this area. (Speed changes using a positioning pattern are not included.)

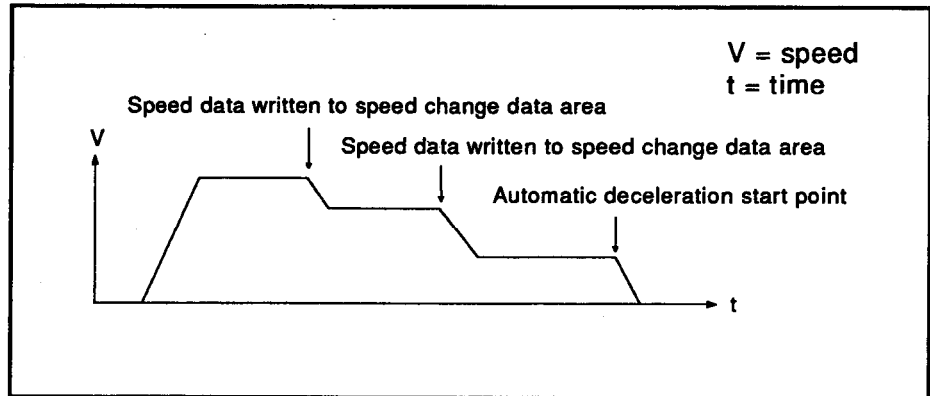

Fig. 3.38 shows a speed change example.

#### POINT

After the speed setting is changed, the speed increases or decreases according to the registered acceleration/deceleration setting.

The speed cannot be changed under the following conditions:

- after an automatic deceleration start point;
- in the manual pulse mode;
- after a stop command is written (to stop positioning), and the JOG signal is turned off during JOG operation;
- during interpolation positioning.

#### 3.6.1 (3) Present value change data area (X axis: addresses 41 and 42; Y axis: addresses 341 and 342)

To change the present value data stored in the AD71, write a new value to this address.

#### POINT

The present value cannot be changed while the AD71 is BUSY. Data must be written to this present value change data area in units of two words. If only one word is rewritten, an error will occur and the present value will not change.

### 3. SPECIFICATIONS

#### 3.6.1 (4) Status area (X axis: address 43; Y axis: address 343)

The information shown in Fig. 3.39 is set by the AD71 OS.

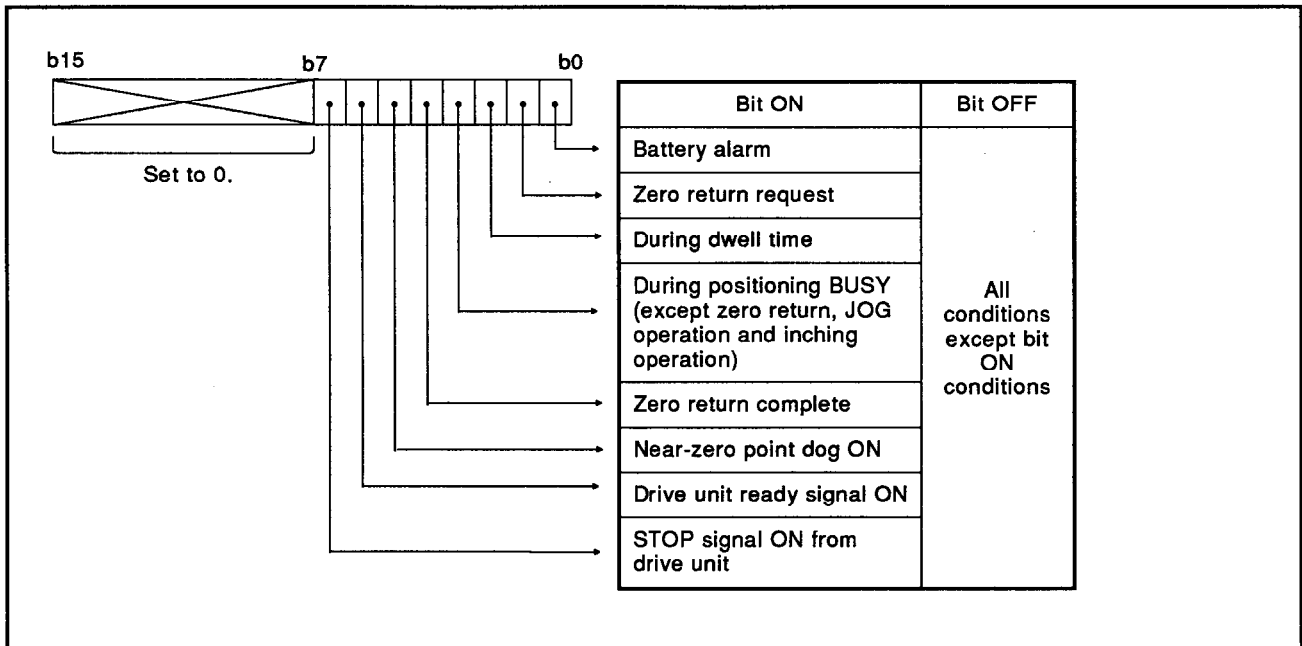

Fig. 3.39 Status Area

#### POINT

Since the AD71 OS writes data to the status area, do not write to it using a sequence program. Only read data from this area.

#### 3.6.1 (5) JOG speed area (X axis: address 44; Y axis: address 344)

To execute JOG operation, write JOG speed data to this area. Writing is possible at any time.

JOG speed data set at the start of JOG operation is valid.

#### 3.6.1 (6) Error code area (X axis: address 45; Y axis: address 345)

When the AD71 OS detects an error and turns on the error detection signal (XB), this area stores an error code.

#### POINTS

- Since the AD71 OS writes data to the error code area, do not write to it using a sequence program. Only read data from this area.
- The most recent error code is written to this area. When no error code exists, or after the error code has been reset, "0" is set here. (It takes about 20 to 30 ms to set the error code after the error detection signal (XB) is turned on.)
- For details of error codes, refer to Chapter 8.

### 3. SPECIFICATIONS

#### 3.6.1 (7) M code area (X axis: address 46; Y axis: address 346)

As shown in Fig. 3.40, the AD71 OS writes the M code specified in the positioning data to this area.

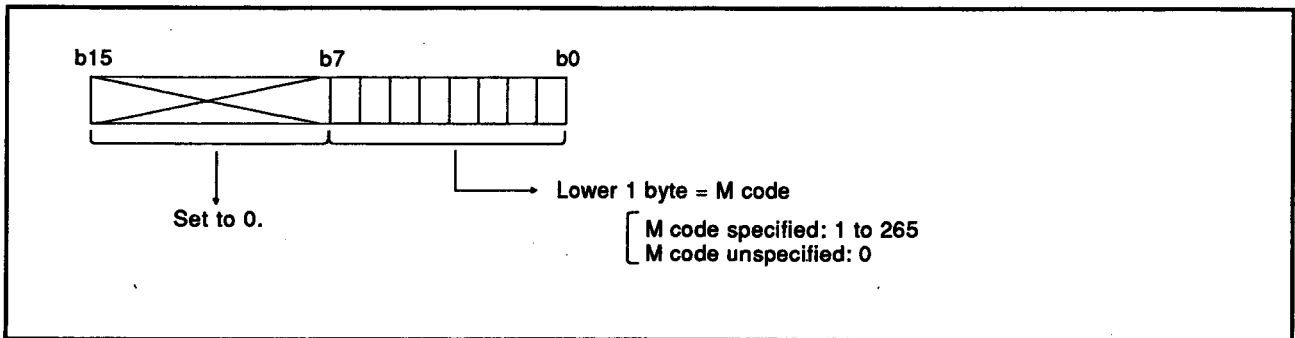

Fig. 3.40 M Code Area

#### POINTS

- Since the AD71 OS writes data to the M code area, do not write to it using a sequence program. Only read data from this area.
- For details of M code data updating timing, refer to 3.5.1 (16).

#### 3.6.1 (8) Manual pulse operation enable area (X axis: address 47; Y axis: address 347) [AD71(S1/S7) and A1SD71-S7 only]

The manual pulse operation enable/disable command is written to b0 as shown in Fig. 3.41. Writing is possible at any time.

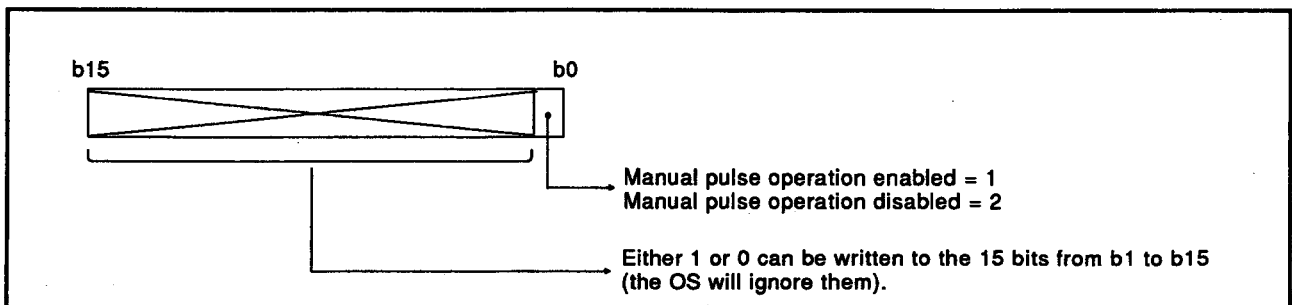

Fig. 3.41 Manual Pulse Operation Enable Area

### 3. SPECIFICATIONS

#### 3.6.1 (9) In-execution data No. area (X axis: address 48; Y axis: address 348)

The AD71 OS writes the data number currently used for positioning to this area.

The data number is retained in this area until the next positioning starts.  
(Refer to Fig. 3.42.)

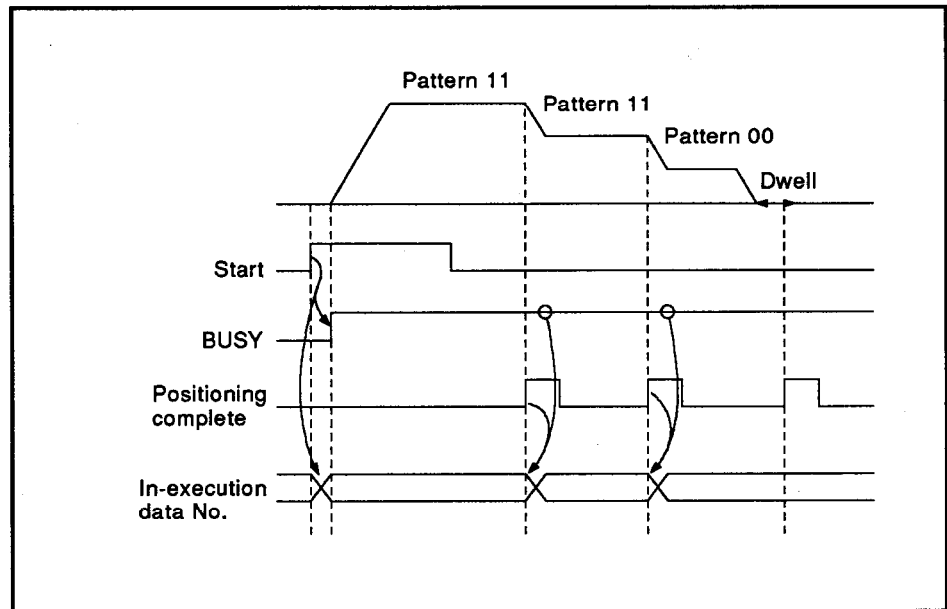

Fig. 3.42 In-Execution Data No. Updating Timing

**POINT**

Since the AD71 OS writes the in-execution data number to this area, do not write to it using a sequence program. Only read data from this area.

#### 3.6.1 (10) M code comment area (X axis: addresses 49 to 200; Y axis: addresses 349 to 500)

M code comments of up to 16 ASCII characters can be registered (with an A6GPP or sequence program).

The M code numbers for which comments are assignable are 1 to 19 for both X and Y axes.

Some methods of using the data are:

- (1) Monitoring data at an A6GPP.
- (2) Using a sequence program, reading data out of the area to display it on another external device.

#### 3.6.1(11) Error reset (Address 201)

The error codes for both axes can be reset by writing a 1 to the least significant bit of this address. This also resets the error detection signal (XB).

The OS then acknowledges that error signals have been reset by writing a 0 to this bit.

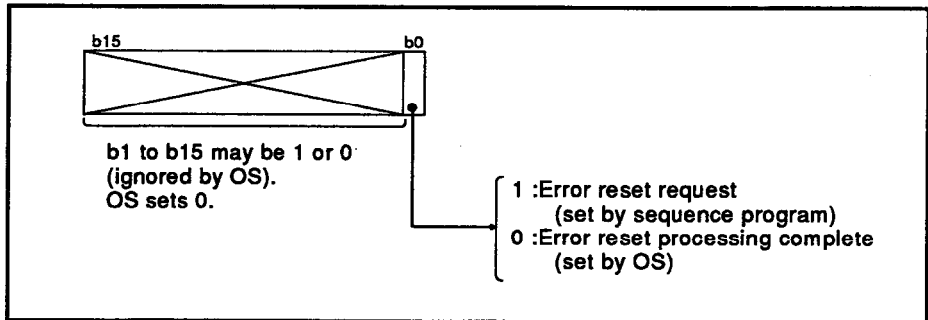

**Fig. 3.43 Error Reset Area Details**

#### 3.6.1(12) Emergency stop area (X axis: 202, Y axis: 502) [AD71S2 and A1SD71-S2 only]

Either emergency stop or normal stop can be selected in this area. Valid during zero return, JOG, and positioning (refer to Section 3.5.1(17)).

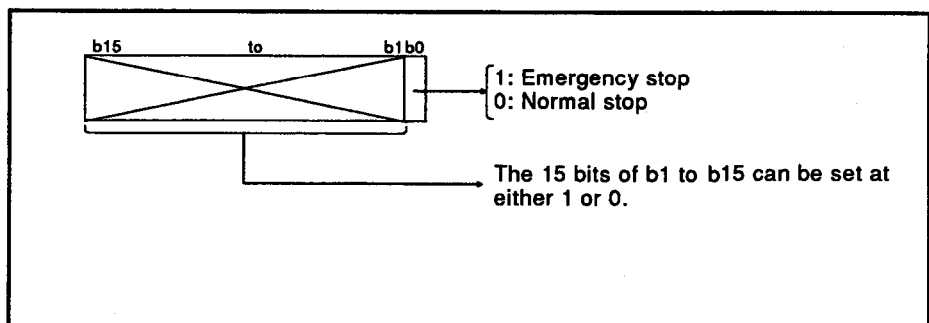

**Fig. 3.44 Emergency Stop Area Details**

#### POINTS

- When setting an emergency stop area to emergency stop (b0 = 1), it stops every time an emergency stop signal is input.
- It can be decelerated and stopped by turning OFF the JOG signal even if a stop signal was not input during the JOG operation. In this case, if an emergency stop area is set, it decelerates and stops in accordance with the emergency stop curve.
- The master axis emergency stop area becomes valid during an interpolation operation. The slave axis emergency stop area of a slave axis will be ignored.

### 3. SPECIFICATIONS

### MELSEC-A

#### 3.6.1(13) Travel distance change areas (X axis: 203, 204, Y axis: 503 to 504) [AD71S2 and A1SD71-S2 only]

Use this area to change the setting travel distance (positioning address) during BUSY in the speed/positioning control switching mode (refer to Section 3.5.4).

#### POINTS

- Data must be written to the travel distance change area in units of two words. (Refer to 6.3.10.)
- Travel distance change is valid only before control switching. Travel distance change is ignored after control switching.

#### 3.6.1(14) Restart areas (X axis: 205, Y axis: 505) [AD71S2 and A1SD71-S2 only]

Use this area to set restart when stopped halfway after a control change in the speed/positioning control switching mode (refer to Section 3.5.4).

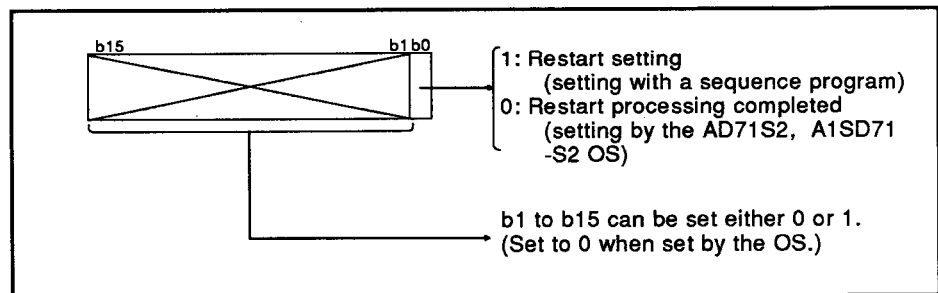

Fig. 3.45 Restart Area



### 3. SPECIFICATIONS

#### 3.6.1 (15) Manual pulse output speed storage area (X axis: address 202; Y axis: address 502) [AD71S7 and A1SD71-S7 only]

This area is used to set the output speed in manual pulse operation.  
During manual pulse operation, positioning proceeds at the speed set in this area.

- (1) The output speed is changeable between 10 pulse/s and 20000 pulse/s (by 10 pulse/s).
- (2) Set the value to one tenth of the desired speed.  
Example) To operate the manual pulse at 2000 pulse/s → Set "200".
- (3) Output speed data cannot be written from any peripheral device.
- (4) Output speed data can be written at any time with a user's sequence program.

However, the written data becomes valid only when the BUSY signal is turned on.

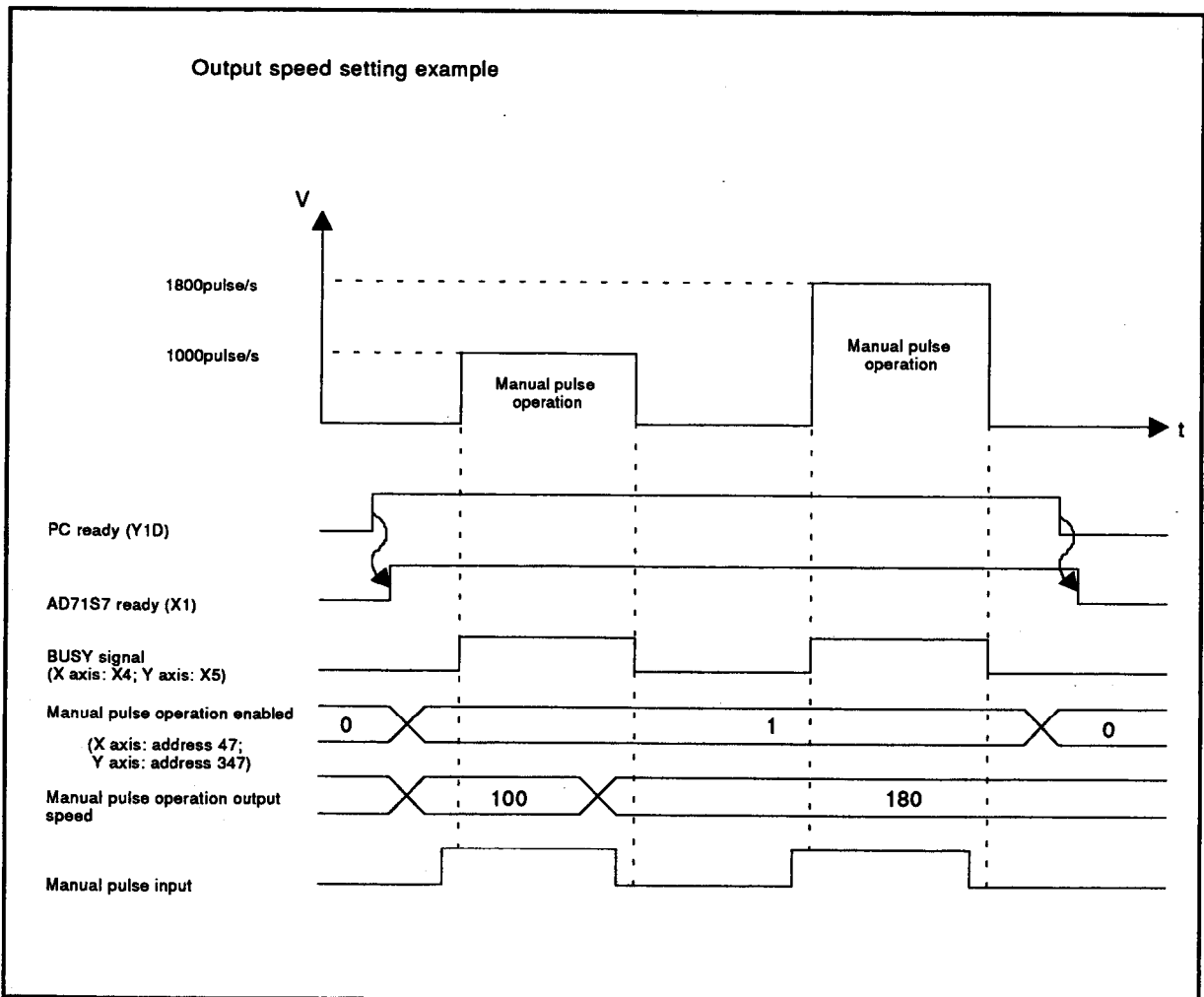

#### 3.6.2 OS data area (Addresses 512 to 767)

Addresses 512 to 767 are used by OS. The user cannot write data in this area. Data shown in Fig. 3.46 can be read and used with a sequence program. (Section 6.3.2 gives details about the reading method.)

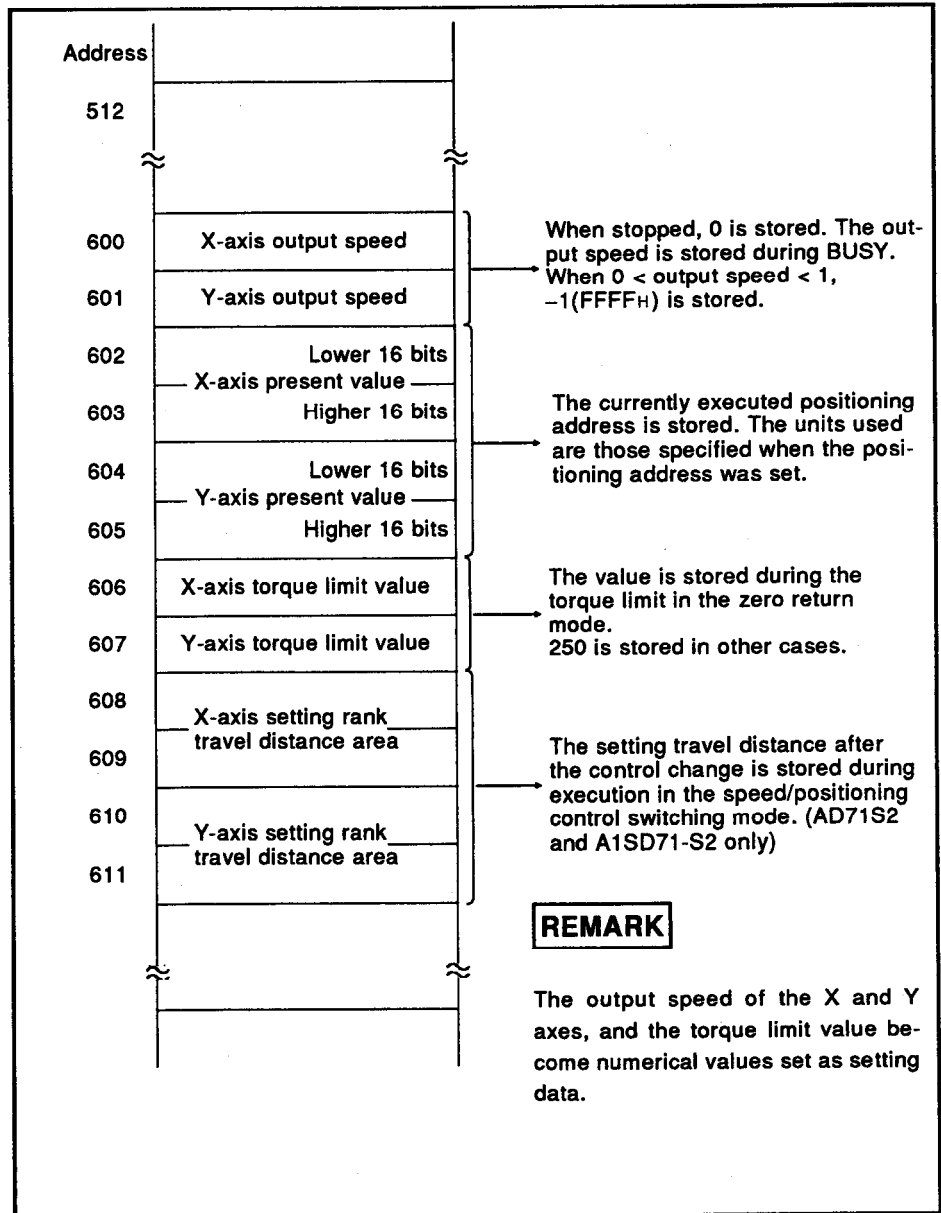

Fig. 3.46 OS Data Area

**POINT**

0 is stored in the setting travel distance area when starting. The value of an address written to a positioning address or a travel distance change area after a switching signal input is set by the OS. The user can confirm the setting travel distance by reading this area.

### 3. SPECIFICATIONS

#### 3.6.3 Positioning data area (X axis :address 3872 to 5871, Y axis :address 5872 to 7871)

This area stores the positioning data explained in Section 3.5.3. The positioning data consists of positioning information, positioning speed, dwell time, and positioning address as shown in Fig. 3.47. For the conversion of expressions from a data number to a buffer memory address, refer to the next page. As an example, for X axis data number = 2, data is stored in the following areas:

- Positioning information :Address = 3873
- Positioning speed :Address = 4273
- Dwell time :Address = 4673
- Positioning address :Address = 5074 (lower 16 bits),  
5075 (upper 16 bits)

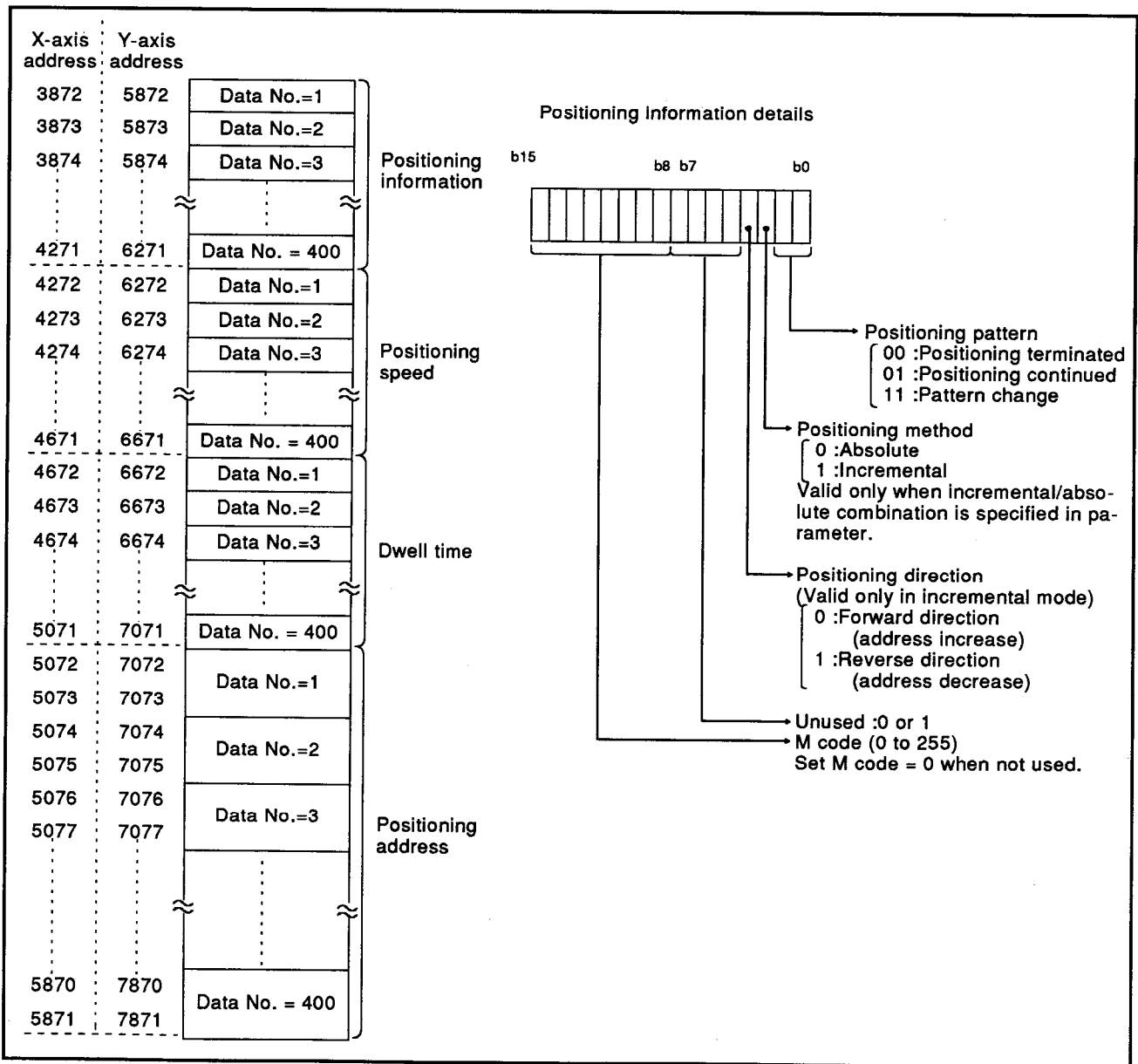

Fig. 3.47 Positioning Data Area

### 3. SPECIFICATIONS

### MELSEC-A

Method of converting from a data number to the buffer memory address

When using a sequence program to set positioning data that corresponds to data numbers, convert data numbers into a buffer memory address by the following:

Conversion of data numbers to buffer memory addresses

	X Axis	Y Axis
Positioning information	$A = 3872 + (\text{data No.} - 1)$ or $A = 3871 + (\text{data No.})$	$A = 5872 + (\text{data No.} - 1)$ or $A = 5871 + (\text{data No.})$
Positioning speed	$A = 4272 + (\text{data No.} - 1)$ or $A = 4271 + (\text{data No.})$	$A = 6272 + (\text{data No.} - 1)$ or $A = 6271 + (\text{data No.})$
Dwell time	$A = 4672 + (\text{data No.} - 1)$ or $A = 4671 + (\text{data No.})$	$A = 6672 + (\text{data No.} - 1)$ or $A = 6671 + (\text{data No.})$
Positioning address	Lower 16 bits $A_2 = 5072 + (\text{data No.} - 1) \times 2$ or $A_2 = 5070 + (\text{data No.}) \times 2$	Lower 16 bits $A_2 = 7072 + (\text{data No.} - 1) \times 2$ or $A_2 = 7070 + (\text{data No.}) \times 2$
	Upper 16 bits $A_1 = A_2 + 1$	Upper 16 bits $A_1 = A_2 + 1$

#### REMARK

A conversion table is given in APPENDIX 5.

### 3. SPECIFICATIONS

#### 3.6.4 Parameter area (X axis: addresses 7872 to 7887; Y axis: addresses 7892 to 7907)

This area is used to store the parameters described in 3.5.1.  
Part of the data varies depending on the positioning module.

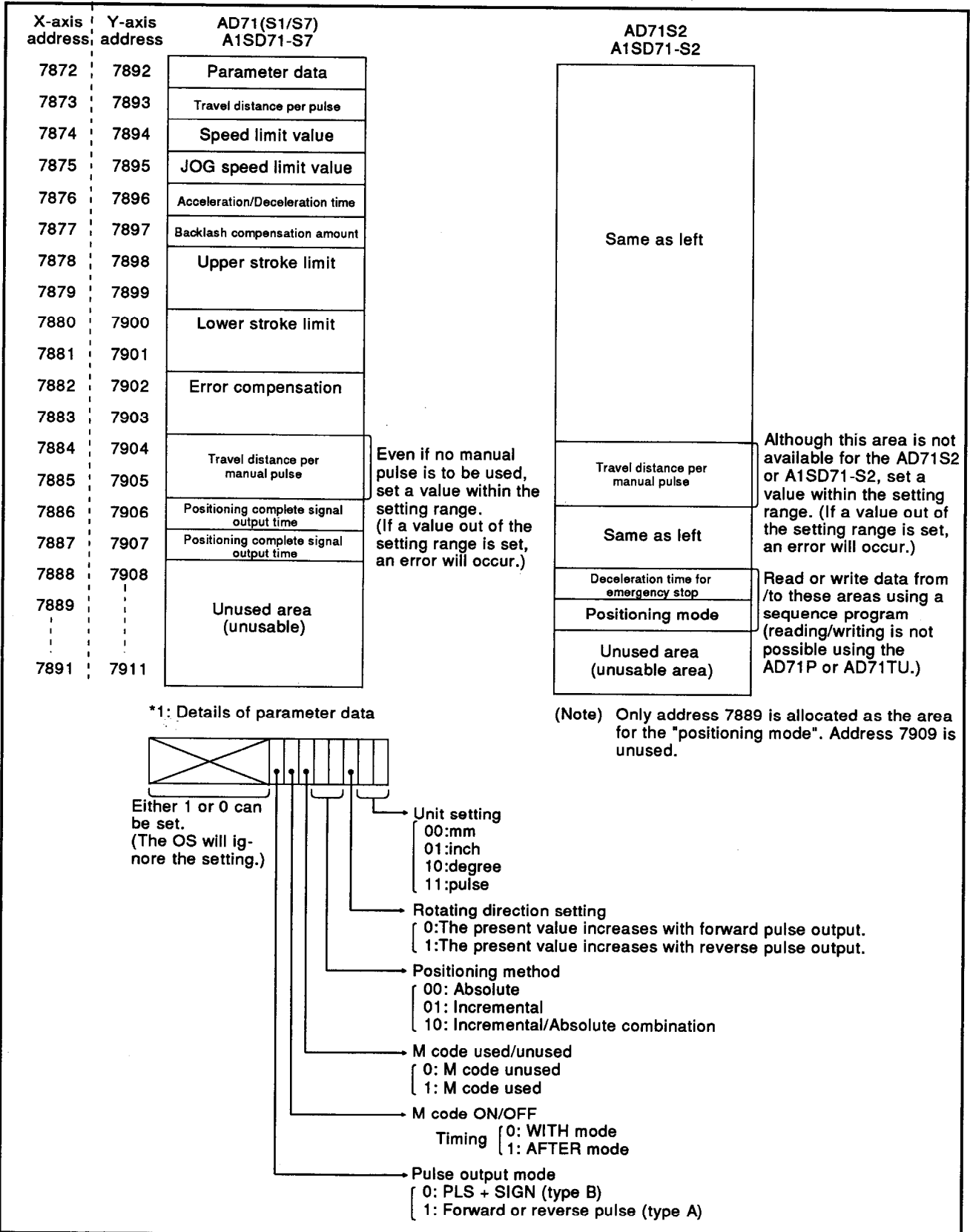

Fig. 3.48 Parameter Area

### 3. SPECIFICATIONS

#### 3.6.5 Zero return data area (X axis :address 7912 to 7918, Y axis :address 7922 to 7928)

Stores Zero return data described in Section 3.5.2.  
See Fig. 3.49.

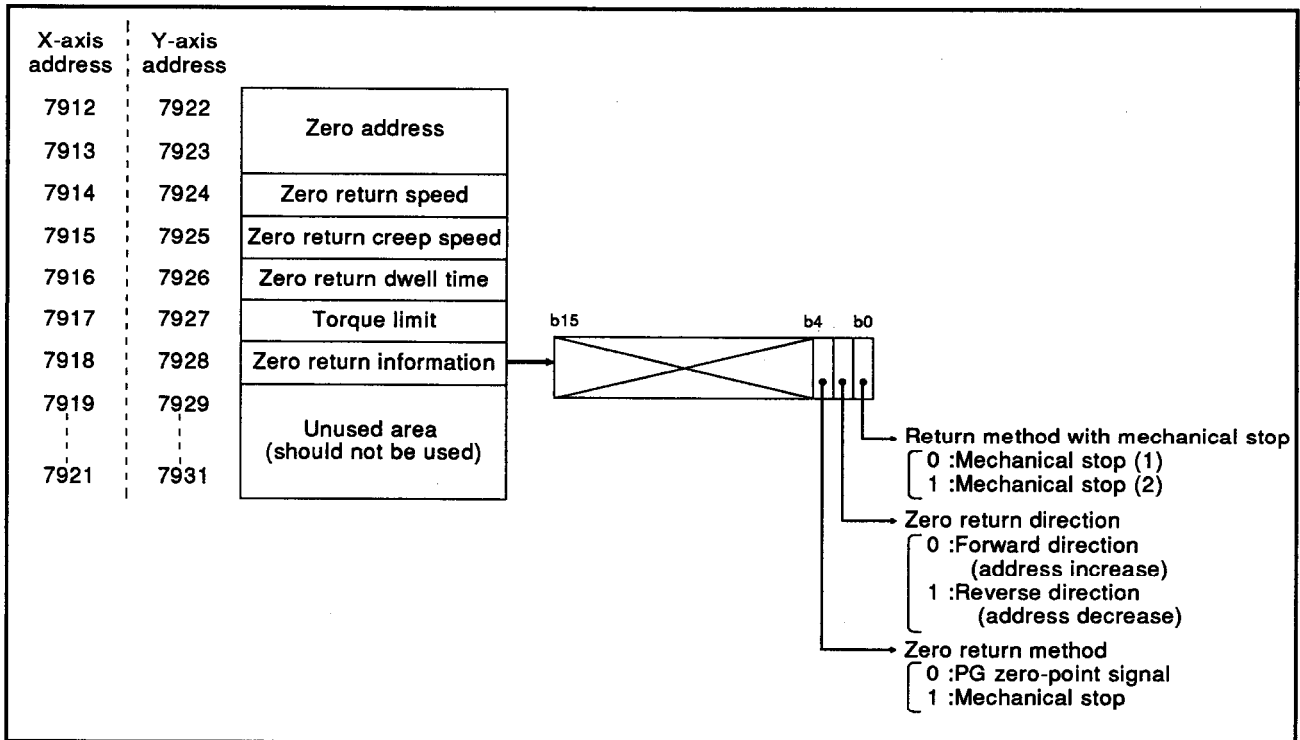

Fig. 3.49 Zero Return Data Area

3.7 I/O Signals From/To PC CPU

The AD71 uses 16 input and 16 output points for data communication with the PC CPU. This section describes I/O signal allocations and functions. The device numbers shown in Table 3.9 I/O Signal List are those when the AD71 is loaded in the following slot of the main base unit:

- (1) AD71(S1/S2/S7)
  - In slot 0 of the main base unit.
- (2) A1SD71-S2(S7)
  - In slot 0 or 1 of the main base unit with the first 16 points set to "vacant slot, 0 points" in I/O allocation using the GPP function.

An X device indicates an input signal from the AD71 to the PC CPU, and a Y device indicates an output signal from the PC CPU to the AD71.

Table 3.9 I/O Signal List

Signal Direction: AD71 → PC CPU		Signal Direction: PC CPU → AD71	
Device No.	Signal	Device No.	Signal
X0	Watchdog timer error (detected by AD71)	Y10	X axis
X1	AD71 ready	Y11	Y axis
X2	X axis	Y12	Interpolation
X3	Y axis	Y13	X axis
X4	X axis	Y14	Y axis
X5	Y axis	Y15	X axis
X6	X axis	Y16	Y axis
X7	Y axis	Y17	X axis forward JOG start
X8	X axis	Y18	X axis reverse JOG start
X9	Y axis	Y19	Y axis forward JOG start
XA	Battery error	Y1A	Y axis reverse JOG start
XB	Error detection	Y1B	X axis
XC	X axis	Y1C	Y axis
XD	Y axis	Y1D	PC ready
XE	X axis	Y1E	Used by system, not available to the user.
XF	Y axis	Y1F	

**IMPORTANT**

Y1E, Y1F and the Y devices having the same numbers as the X devices (Y0 to YF) are used by the system, and are therefore not available for use by the user.

If any of the above devices is used (ON/OFF) with a sequence program, normal functioning of the AD71 cannot be ensured. (YD to YF only need to be controlled using the sequence program when the AD71 is loaded in a remote I/O station. For details, refer to 6.4.)

## Detailed explanation of I/O signals

This section explains ON/OFF timing of I/O signals and I/O signal conditions. The numbers in ( ) shows the device number that corresponds to Table 3.9.

Fig 3.50 gives details about ON/OFF timing of I/O signals.

## (1) Watchdog timer error signal (X0)

Switches ON when a WDT error occurs by using the A1SD71 self-diagnostic function.

## (2) AD71 ready signal (X1)

Switches ON according to the ON/OFF state of the PC ready signal (Y1D). However, following time (t), the AD71 ready signal (X1) must be turned ON after checking parameter and zero return data when the PC ready signal (Y1D) goes ON.

Use this signal for the interlock in the sequence program.

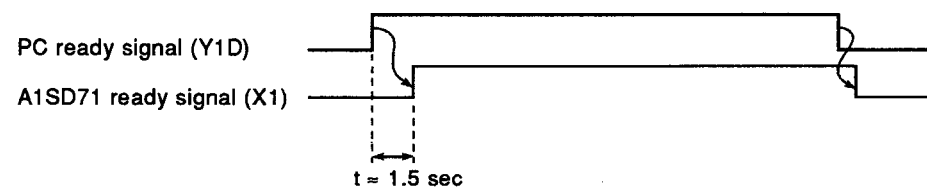

## (3) Positioning complete (X2, X3)

Switches on for a period set in the parameters after each position is reached. (Ignored if the positioning complete signal output time = 0.)

Switched off at positioning start, Zero return start, inching start, jog start, and power on.

If positioning is stopped midway, the positioning complete signal does not switch on.

Positioning complete signals do not go on in the speed control mode.

## (4) BUSY (X4, X5)

Switches on at positioning start, Zero return start, inching start, and jog start. Switches off after pulse output and dwell time have elapsed.

(Refer to Fig. 3.50.) (Remains on during positioning.)

Switches on while the test function is being used on the peripheral device.



(5) Zero return request signals (X6, X7)

Switches ON when either of the following conditions occurs, and OFF when zero return is complete.

When the power supply is turned ON to the AD71 module  
 When the drive unit READY signal ( $\overline{\text{READY}}$ ) goes OFF during BUSY  
 After the PC ready signal (Y1D) goes ON, it takes about 1.5 seconds  
 When a parameter and a zero return data are written from the peripheral device

When zero return starts

When the following are selected in test mode of a peripheral device:

- 1) Zero return
- 2) Positioning
- 3) JOG operation
- 4) Manual pulser

(6) Positioning commenced signals (X8, X9)

When the AD71 starts positioning processing by positioning (zero return and the JOG operation are contained) and the start signal turns ON, these signals go ON. Then, these signals go OFF when the start signal turns OFF.

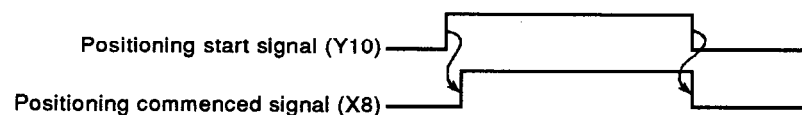

Not turned ON in the test mode by a peripheral device or AD71TU.

(7) Battery error (XA)

Switches on when battery voltage drops.

(8) Error detection (XB)

Switched on by any of the errors in Chapter 8. Switched off when the error is reset. For resetting, refer to Section 3.6.1 (11).

(9) Zero return complete (XC, XD)

Switches on to indicate the completion of zero return. Switched off by starting JOG operation, positioning, or manual pulse generator mode operation.

(10) M code ON signals (XE, XF)

These are turned ON when starting in the WITH mode.

When positioning is completed, they are turned ON in the AFTER mode.

When an M code OFF signal goes ON, the M code ON signal goes OFF.

If the M code is not designated (when M code is set to 0), the M code ON signal remains OFF.

This signal remains OFF in the test mode when using a peripheral device.

**Remark**

M code consists of the code numbers (1 to 255) allocated by a user to execute auxiliary functions (for example, clamp, drill rotation, stop, and tool exchange command) after positioning control using an AD71.

The PC CPU can execute specified auxiliary tasks by creating programs to go ON and OFF a relay ladder by using this M code.

- (11) Positioning start (Y10, Y11, Y12)  
Become valid at the leading edge of this signal.
- (12) Zero return start (Y13, Y14)  
Become valid at the leading edge of this signal.
- (13) Stop (Y15, Y16)  
One of these signals being ON stops zero return and positioning and JOG operations and manual pulse generator operation.  
(If these signals are turned ON during BUSY, the M code ON signal goes OFF.)  
After an operation stops, operations can be restarted by a positioning start signal. (Section 6.3.11 gives details about concrete examples.)
- (14) JOG operation (Y17 to Y1A)  
When these signals go ON, a JOG operation is executed. Operations are decelerated and stopped automatically by turning OFF this signal.
- (15) M code OFF (Y1B, Y1C)  
The leading edge of these signals makes the M code ON signal go OFF.
- (16) PC ready signal (Y1D)  
Sends the correct PC CPU operation to the AD71.  
At the start of positioning, zero return jog operations (other than those carried out in a peripheral device or AD71TU) this signal must be ON. However, if one axis is in BUSY in the test mode when using a peripheral device, the leading edge of the PC ready signal is ignored. Then, when both axes are not in BUSY, execution takes place.
  - 1) Parameter checking and initialization
  - 2) Zero return data check
  - 3) Zero return request ON, AD71 ready signal ON

The following time (t) the signal of 3) after a PC ready signal goes ON must go ON to process 1) and 2).

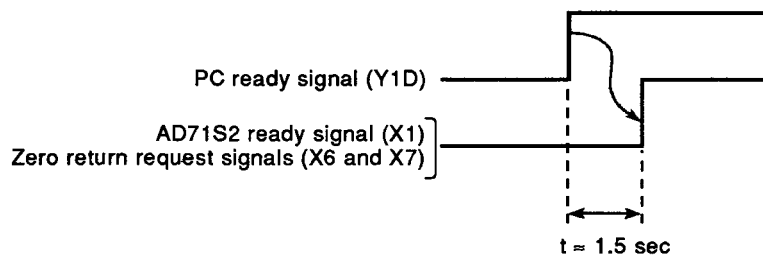

If the PC ready signal goes OFF when AD71 is BUSY, positioning is stopped. Then, the M code ON signal goes OFF, and the M code is cleared. However, even if the PC ready signal goes OFF in BUSY when using a peripheral device in the test mode, positioning does not stop.

#### [Jog operation]

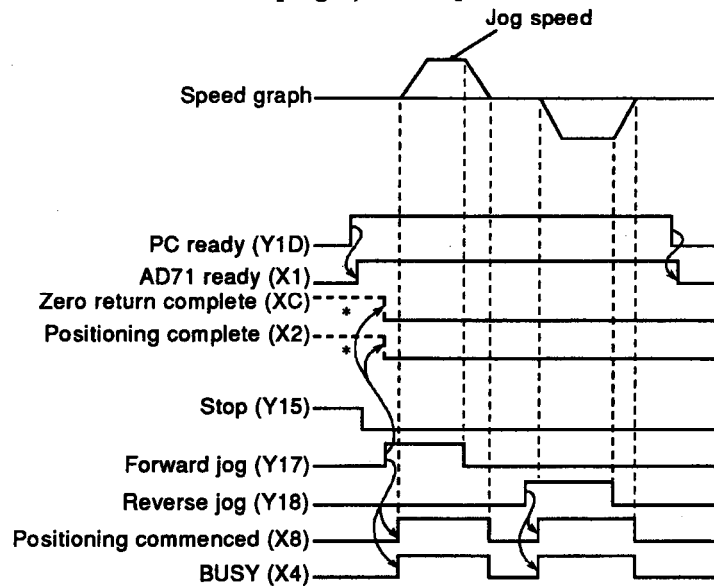

#### [Positioning operation]

##### Positioning control mode

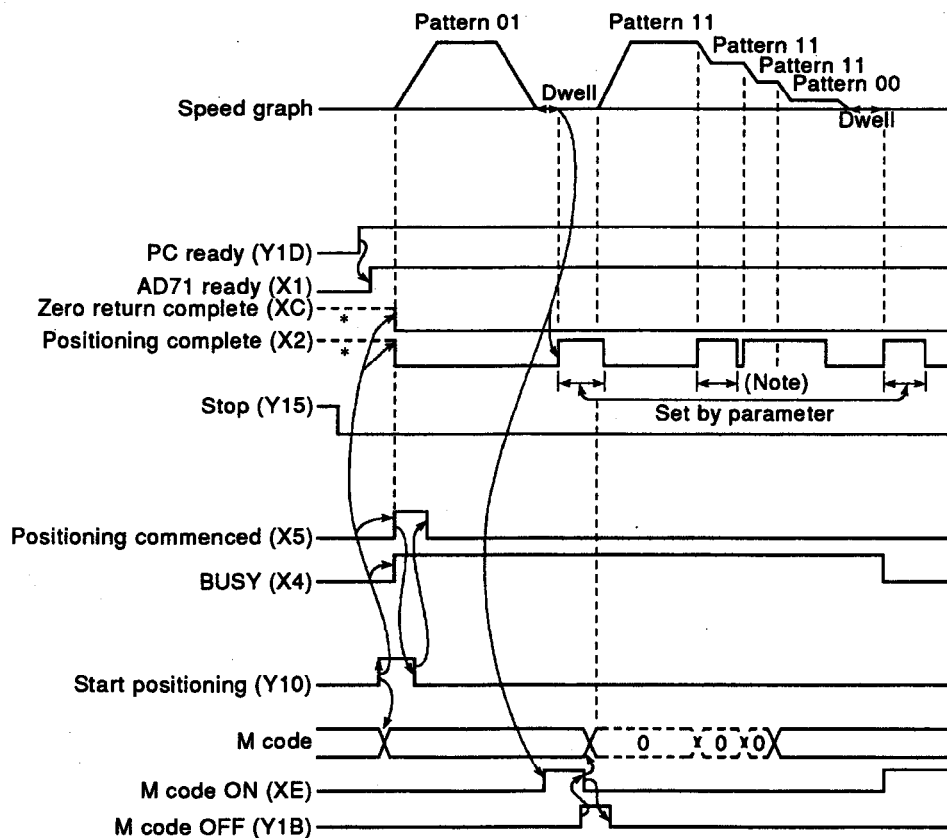

Note : If positioning operation is shorter than the positioning complete signal output time in the parameter, the positioning complete signal may be output continuously.

\* : When a signal with a \* symbol is ON before the positioning start signal goes ON, the signal with the \* symbol goes OFF when the positioning start signal goes ON.

[Positioning operation]

Speed/positioning control switching mode with an AD71S2 or A1SD71-S2

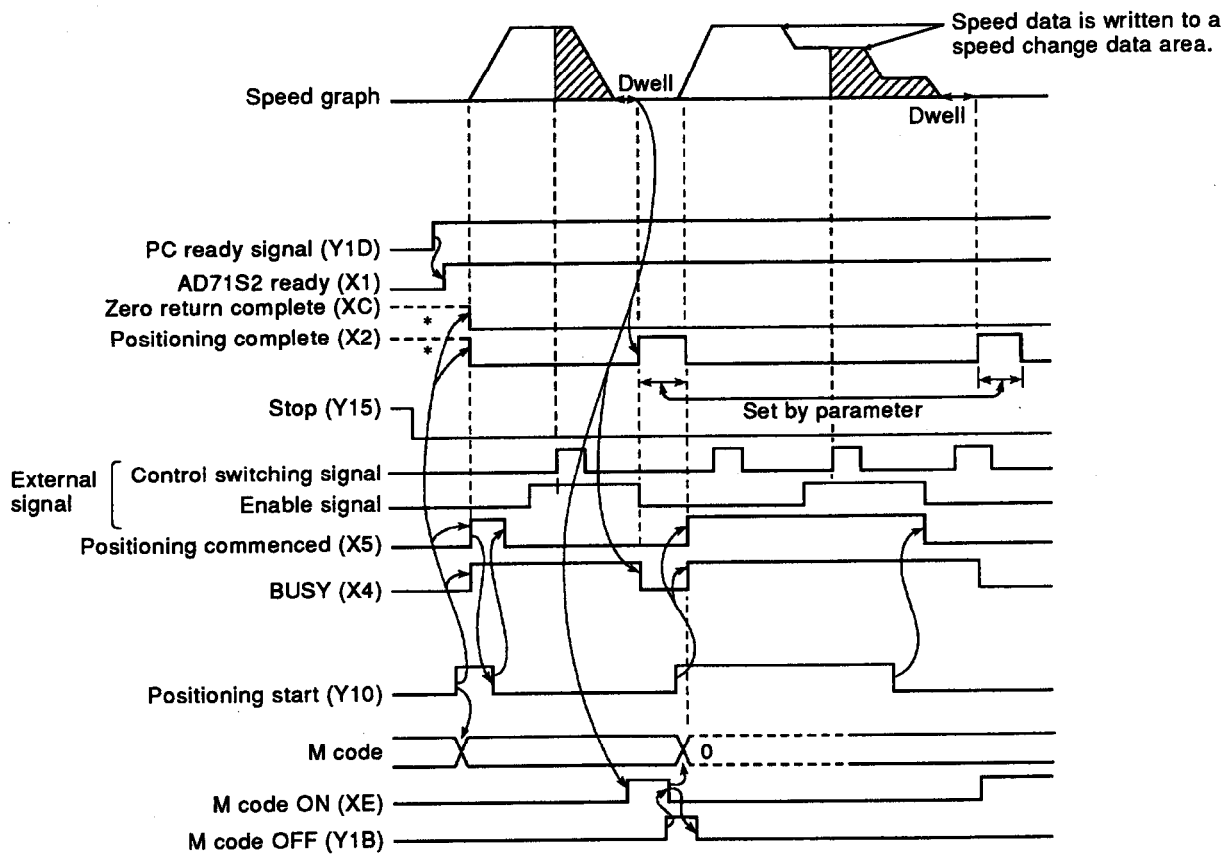

Note : When a positioning operation is shorter than the output time of a parameter's positioning complete signal, the positioning complete signal is sometimes output continuously.

[Zero return]

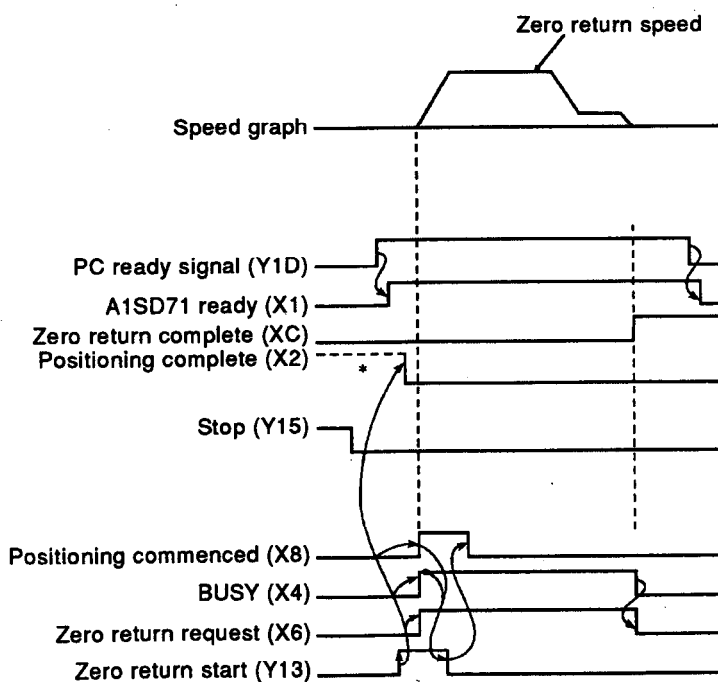

Note : When a signal with a \* symbol is ON before the positioning start signal goes ON, the signal with the \* symbol goes OFF when the positioning start signal goes ON.

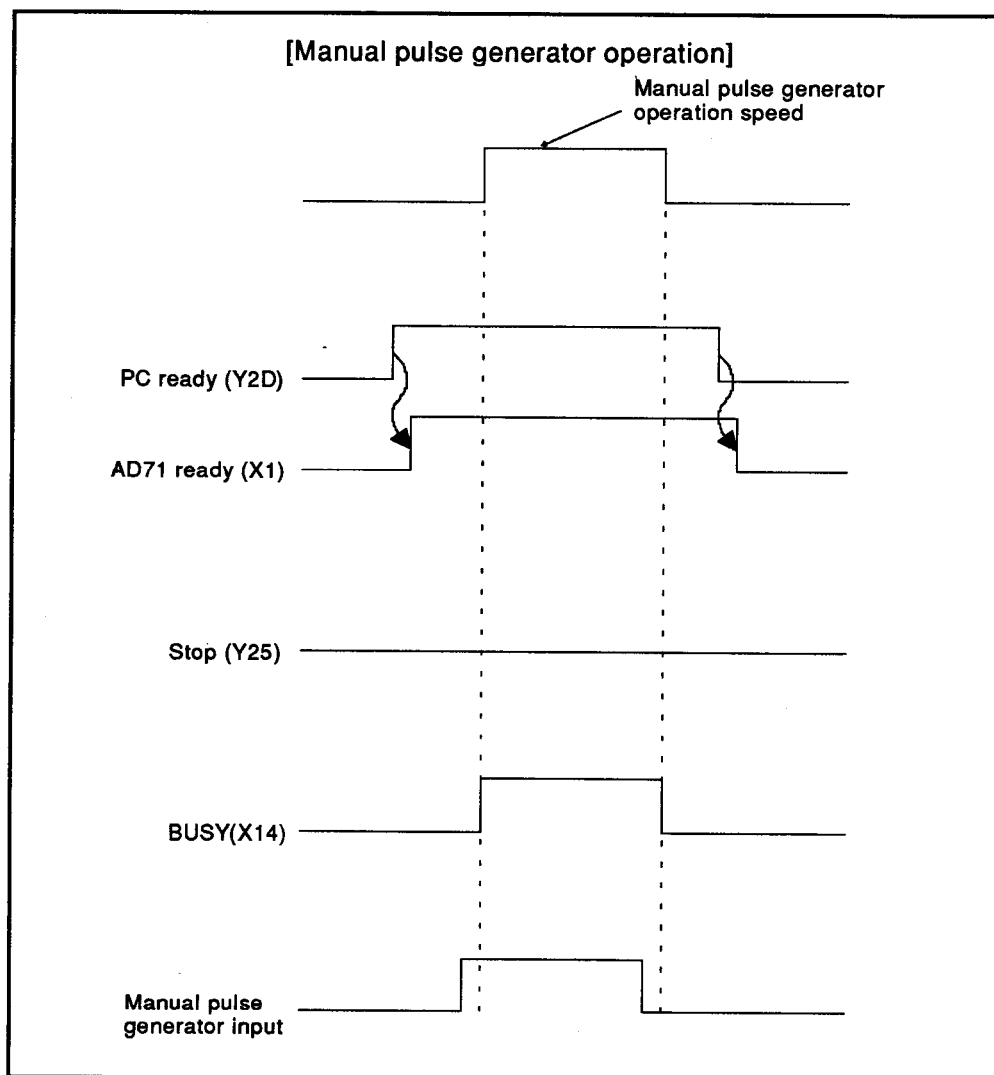

Fig. 3.50 I/O Signal ON/OFF Timing

3.8 I/O Interface with External Equipment

This section describes the I/O interface between the AD71 and external equipment.

3.8.1 AD71 electrical specifications

Table 3.10 shows the electrical specifications of AD71 I/O signals.

Table 3.10 AD71 Electrical Specifications

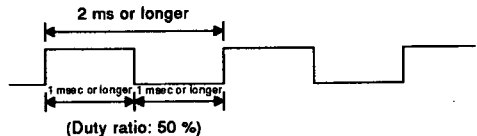
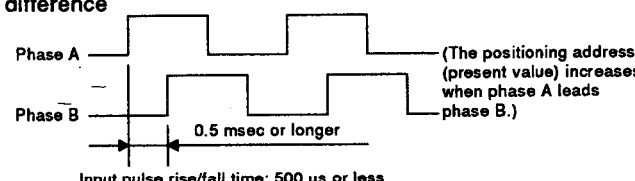
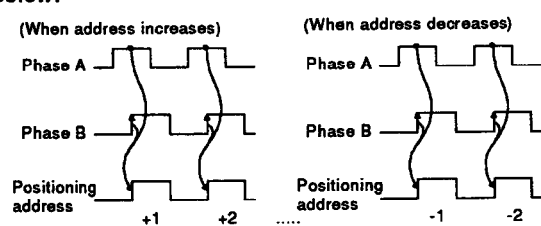
I/O	Signal	Description
Input (5 to 24 VDC)	Supply power	5 to 24 VDC (Prepare a 4.75 to 26.4 V stabilized power supply.) 50mA (maximum)
	Drive unit ready (READY) Stop signal (STOP) Near-point signal (DOG)	High : (Supply power voltage - 1 V) or more (Input current : 0.3 mA or less) Low : (Supply power voltage - 3 V) or less (Input current : 2.5 mA or more)
	Manual pulse generator phase A (PULSER A) Manual pulse generator phase B (PULSER B) [AD71(S1/S7) and A1SD71-S7 only]	Input signal voltage level HIGH level: voltage - 4.5 V or higher; current - 3 mA or higher LOW level: voltage - 1.0 V or less; current 0 mA Pulse width  Phase difference  Input pulse rise/fall time: 500 μs or less Timing The positioning address set by the manual pulse generator varies as shown below: 
Zero phase signal (PGO)	High : (Supply power voltage - 1V) or more (Input current : 0.3mA or less) Low : (Supply power voltage - 3V) or less (Input current : 2.5mA or more) Pulse width : 50 μs or more Pulse rise time : 3 μs or less Pulse fall time : 3 μs or less	
Input (5 VDC)	Supply power [AD71S2 and A1SD71-S2 only]	5 VDC (Prepare 4.75 to 5.25 V stabilized power supply.)
	Control switching signal Enable signal [AD71S2 and A1SD71-S2 only]	HIGH level : Voltage 4.5 V or more Current 3 mA or more LOW level : Voltage 1.0 V or less Current 0 mA Pulse width : 1 ms or more Response time from OFF to ON : 1 ms

### 3. SPECIFICATIONS

MELSEC-A

I/O	Signal	Description
Output	Start signal ( <u>START</u> ) Error detector clear ( <u>CLEAR</u> ) Direction sign ( <u>SIGN</u> )*	Output form : Open collector Load voltage : 4.75 to 26.4 VDC Load current : 10 mA (maximum) Max. drop voltage when ON : 0.6 V or less Leakage current when OFF : 0.1 mA or less
	Forward feed pulse ( <u>PULSE F</u> ) Reverse feed pulse ( <u>PULSE R</u> ) [AD71 (S2/S7) and A1SD71-S2(S7) only]	Output form : Open collector, output duty ratio 50 % ± 10 % When A1SD71-S2(S7) is used: Pulse rise time : 0.5 μs or less Pulse fall time : 0.5 μs or less } Refer to Table 3.11. Load voltage : 4.75 to 26.4 VDC Load current : 20 mA (maximum) ... 50mA (maximum) when A1SD71-S2(S7) is used Use within the range 2mA to 15mA. If it is less than 2 mA, add a dummy resistor.

\*: AD71S1(S7) and A1SD71-S7 only

Table 3.11 Pulse Rise/Fall Times of A1SD71-S2(S7)

Unit tf, tr : μs Duty : %

Load Voltage (V)		26.4								
Cable Length (m)		1			2			3		
Load Current (mA)	Pulse Speed (kPPS)	tf (Leading edge)	tr (Trailing edge)	Duty	tf (Leading edge)	tr (Trailing edge)	Duty	tf (Leading edge)	tr (Trailing edge)	Duty
2	200	< 0.1	1.7	32	< 0.1	1.8	30	< 0.1	1.8	28
	100		3.0	40		3.4	36		3.6	32
	10		3.2	49		6.0	49		9.0	48
10	200	< 0.1	0.7	42	< 0.1	1.0	40	< 0.1	1.6	38
	100		0.7	46		1.1	45		1.6	44
	10		0.7	50		1.1	50		1.6	50
50	200	< 0.1	0.4	46	< 0.1	0.5	46	< 0.1	0.5	45
	100		0.4	48		0.5	48		0.5	48
	10		0.4	50		0.5	50		0.5	50

Unit tf, tr : μs Duty : %

Load Voltage (V)		4.75								
Cable Length (m)		1			2			3		
Load Current (mA)	Pulse Speed (kPPS)	tf (Leading edge)	tr (Trailing edge)	Duty	tf (Leading edge)	tr (Trailing edge)	Duty	tf (Leading edge)	tr (Trailing edge)	Duty
2	200	< 0.1	0.6	46	< 0.1	1.0	44	< 0.1	1.3	42
	100		0.6	49		1.0	47		1.3	46
	10		0.6	50		1.0	50		1.5	50
10	200	< 0.1	0.3	50	< 0.1	0.4	50	< 0.1	0.4	50
	100		0.3	50		0.4	50		0.4	50
	10		0.3	50		0.4	50		0.4	50
50	200	0.1	0.3	52	0.1	0.3	52	0.1	0.3	52
	100		0.3	52		0.3	52		0.3	52
	10		0.3	50		0.3	50		0.3	50

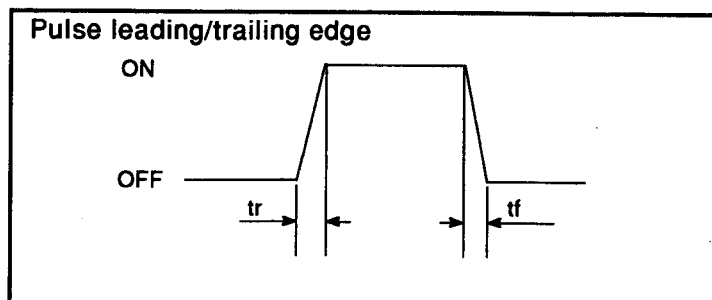

### 3. SPECIFICATIONS

#### 3.8.2 Input/output interface specifications of the AD71 and an external device

The input/output interface specifications of the AD71 and an external device are given in the following table.

(1) AD71(S7), A1SD71-S7 I/O Interfaces

I/O	Internal Circuit	Pin Number		Signal	Description
		X axis	Y axis		
Input		5A	7A	Common	5 to 24 VDC (external supply)
				Drive unit ready (READY)	(1) LOW indicates the servo drive unit is serviceable and the feed pulse is acceptable. (2) The AD71 checks the drive unit ready signal prior to start. If not ready, the AD71 outputs a zero return request. (3) Arrange for drive unit errors, e.g. a control power error, to set this signal HIGH. (4) Switching the signal to HIGH during positioning stops the operation. Resetting the signal will not restart the operation.
				Stop signal (STOP)	(1) LOW to stop positioning. Signal duration 20 msec or more. (2) AD71 stops positioning by using this signal and switches the start signal OFF (HIGH). When switching from HIGH to LOW, positioning is not started.
				Zero-point signal (DOG)	(1) Used to detect near-point during zero return. Switched to LOW by using the near-point actuator. The grid point is resolver phase angle 0. (2) When zero return by using the zero-phase signal, the zero point is away from the dog and becomes the first grid point after detecting the near-point dog.
		1A	3A	Manual pulse generator phase A (PULSER A)	Signal shown in Table 3.10.
		1B	3B		
		2A	4A	Manual pulse generator phase B (PULSER B)	Signal shown in Table 3.10.
		2B	4B		
		9A	10A	Zero-phase signal (PGO)	(1) Used as the zero signal at zero return. The zero-phase grid signal of the pulse encoder is normally used. LOW at zero. (2) Used when the zero return method uses stopper stop and zero return complete is externally input.
		9B	10B		



### 3. SPECIFICATIONS

I/O	Internal Circuit	Pin Number		Signal	Description		
		X axis	Y axis				
Output		11A	13A	Start (START)	(1) LOW while positioning. (2) ON (LOW) during feed pulse output and dwell. Used as a brake release signal for servos with mechanical brakes. Feed pulse is output after this signal goes ON.		
		11B	13B				
		12A	14A	Error counter clear (CLEAR)	Given before and after zero return. Resets deviations in the servo error counter. 		
		12B	14B				
		17A	20A	(+) 24 V power	5 to 24 VDC (external supply) 17B and 20B for 5 to 15 VDC. 17A and 20A for 24 VDC. <div style="border: 1px solid black; padding: 2px; width: fit-content;"> <b>POINT</b>                          Supplied from either one.                          Improper wiring may fail the module.                     </div>		
		17B	20B	(+) 5 to 15 V power			
		15A	18A	A type	Forward feed pulse PULSE F	B type Feed pulse PULSE	Forward and reverse feed pulses The operation direction follows the direction sign (SIGN). 
		15B	18B				
		16A	19A		Reverse feed pulse PULSE R	Direction sign SIGN	A type PULSE F
		16B	19B				

Select the A or B type by parameter setting. (For details, refer to Section 3.5.1.)

### 3. SPECIFICATIONS

(2) AD71S1 I/O Interfaces

I/O	Internal Circuit	Pin Number		Signal	Description
		X axis	Y axis		
Input		5A	7A	Common	5 to 24 VDC (external supply)
				Drive unit ready (READY)	<ul style="list-style-type: none"> <li>(1) LOW indicates the servo drive unit is serviceable and the feed pulse is acceptable.</li> <li>(2) The A1SD71 checks the drive unit ready signal prior to start. If not ready, the A1SD71 outputs a zero return request.</li> <li>(3) Arrange for drive unit errors, e.g. a control power error, to set this signal HIGH.</li> <li>(4) Switching the signal to HIGH during positioning stops the operation. Resetting the signal will not restart the operation.</li> </ul>
				Stop signal (STOP)	<ul style="list-style-type: none"> <li>(1) LOW to stop positioning. Signal duration 20 msec or more.</li> <li>(2) A1SD71 stops positioning by using this signal and switches the start signal OFF (HIGH). When switching from HIGH to LOW, positioning is not started.</li> </ul>
				Zero-point signal (DOG)	<ul style="list-style-type: none"> <li>(1) Used to detect near-point during zero return. Switched to LOW by using the near-point actuator. The grid point is resolver phase angle 0.</li> <li>(2) When zero return by using the zero-phase signal, the zero point is away from the dog and becomes the first grid point after detecting the near-point dog.</li> </ul>
				Manual pulse generator phase A (PULSER A)	Signal shown in Table 3.10.
				Manual pulse generator phase B (PULSER B)	Signal shown in Table 3.10.
				Zero-phase signal (PGO)	<ul style="list-style-type: none"> <li>(1) Used as the zero signal at zero return. The zero-phase grid signal of the pulse encoder is normally used. LOW at zero.</li> <li>(2) Used when the zero return method uses stopper stop and zero return complete is externally input.</li> </ul>

### 3. SPECIFICATIONS

MELSEC-A

I/O	Internal Circuit	Pin Number		Signal	Description
		X axis	Y axis		
Output		11A	13A	Power (+)	5 to 24 VDC (external supply)
			11B	13B	Start (START)
		12A	14A	Error counter clear (CLEAR)	Given before and after zero return. Resets deviations in the servo error counter.  
		15A	17A	Feed pulse output	Pulse train commands lagging slightly behind direction sign SIGN.  
		15B	17B	PULSE	
		16A	18A	Feed pulse sign	SIGN
		16B	18B	SIGN	

### 3. SPECIFICATIONS

MELSEC-A

#### (3) AD71S2, A1SD71-S2 I/O Interfaces

I/O	Internal Circuit	Pin Number		Signal	Description	
		X axis	Y axis			
Input		5A	7A	Common	5 to 24 VDC (external supply)	
					Drive unit ready (READY)	<ul style="list-style-type: none"> <li>(1) LOW indicates the servo drive unit is serviceable and the feed pulse is acceptable.</li> <li>(2) The A1SD71 checks the drive unit ready signal prior to start. If not ready, the A1SD71 outputs a zero return request.</li> <li>(3) Arrange for drive unit errors, e.g. a control power error, to set this signal HIGH.</li> <li>(4) Switching the signal to HIGH during positioning stops the operation. Resetting the signal will not restart the operation.</li> </ul>
					Stop signal (STOP)	<ul style="list-style-type: none"> <li>(1) LOW to stop positioning. Signal duration 20 msec or more.</li> <li>(2) A1SD71 stops positioning by using this signal and switches the start signal OFF (HIGH). When switching from HIGH to LOW, positioning is not started.</li> </ul>
					Zero-point signal (DOG)	<ul style="list-style-type: none"> <li>(1) Used to detect near-point during zero return. Switched to LOW by using the near-point actuator. The grid point is resolver phase angle 0.</li> <li>(2) When zero return by using the zero-phase signal, the zero point is away from the dog and becomes the first grid point after detecting the near-point dog.</li> </ul>
					Enable signal	<ul style="list-style-type: none"> <li>(1) Used to select control switching signal enable/disable.</li> <li>(2) LOW enables the control switching signal.</li> </ul>
					Control switching signal	<ul style="list-style-type: none"> <li>(1) Used as the control switching command in the speed/positioning control switching mode.</li> <li>(2) LOW selects positioning control.</li> </ul>
					Zero-phase signal (PGO)	<ul style="list-style-type: none"> <li>(1) Used as the zero signal at zero return. The zero-phase grid signal of the pulse encoder is normally used. LOW at zero.</li> <li>(2) Used when the zero return method uses stopper stop and zero return complete is externally input.</li> </ul>

### 3. SPECIFICATIONS

I/O	Internal Circuit	Pin Number		Signal	Description	
		X axis	Y axis			
Output		11A	13A	Start (START)	(1) LOW while positioning. (2) ON (LOW) during feed pulse output and dwell. Used as a brake release signal for servos with mechanical brakes. Feed pulse is output after this signal goes ON.	
		11B	13B			
		12A	14A	Error counter clear (CLEAR)	Given before and after zero return. Resets deviations in the servo error counter.  	
		12B	14B			
		17A	20A	(+) 24 V power	5 to 24 VDC (external supply) 17B and 20B for 5 to 15 VDC. 17A and 20A for 24 VDC.  <div style="border: 1px solid black; padding: 2px;"> <b>POINT</b>                      Supplied from either one.                      Improper wiring may fail the module.                 </div>	
		17B	20B	(+) 5 to 15 V power		
		15A	18A	A type Forward feed pulse PULSE F	B type Feed pulse PULSE	Forward and reverse feed pulses The operation direction follows the direction sign (SIGN). 
		15B	18B			
		16A	19A	Reverse feed pulse PULSE R	Direction sign SIGN	
		16B	19B			

### 3.9 Battery Specifications

Table 3.12 gives the specifications of a battery used for an AD71.

Table 3.12 Battery Specifications

Items	Type	A6BAT
Type		Thionyl chloride lithium battery
Nominal voltage		3.6 VDC
Guarantee period		5 years
Total power failure time		300 days (7200 hours)
Application		Back-up for setting data
Size (mm)		φ 16 (dia) × 30

### 4. HANDLING

This section explains the handling (installation preparations) and nomenclature of the AD71.

#### 4.1 Handling Instructions

- (1) Since the body case is made of plastic, protect the A1SD71 from dropping and sudden impacts.
- (2) Take care not to allow conductive debris, such as wire scraps generated during wiring or chips produced by drilling, to drop into the module. If debris does get into the module, remove it.
- (3) Turn the PC CPU power supply OFF before installing or removing the unit to or from the base.  
Refer to 5.3 for details on mounting and removing the positioning module.
- (4) Turn the PC CPU and drive module power supply OFF before connecting or disconnecting the drive unit connector.  
After confirming the correct insertion direction, insert the connector directly from the front. Then, tighten the two fixing screws.  
When the drive unit is not connected, keep the connector area cover closed.
- (5) When the AD71 is not BUSY, connect a peripheral device the AD71.  
After confirming the correct insertion direction, insert the connector directly from the front. Then, tighten the two fixing screws.  
When a peripheral device is not connected, keep the connector area cover closed.

4.2 Nomenclature

This section provides the part names of the AD71.

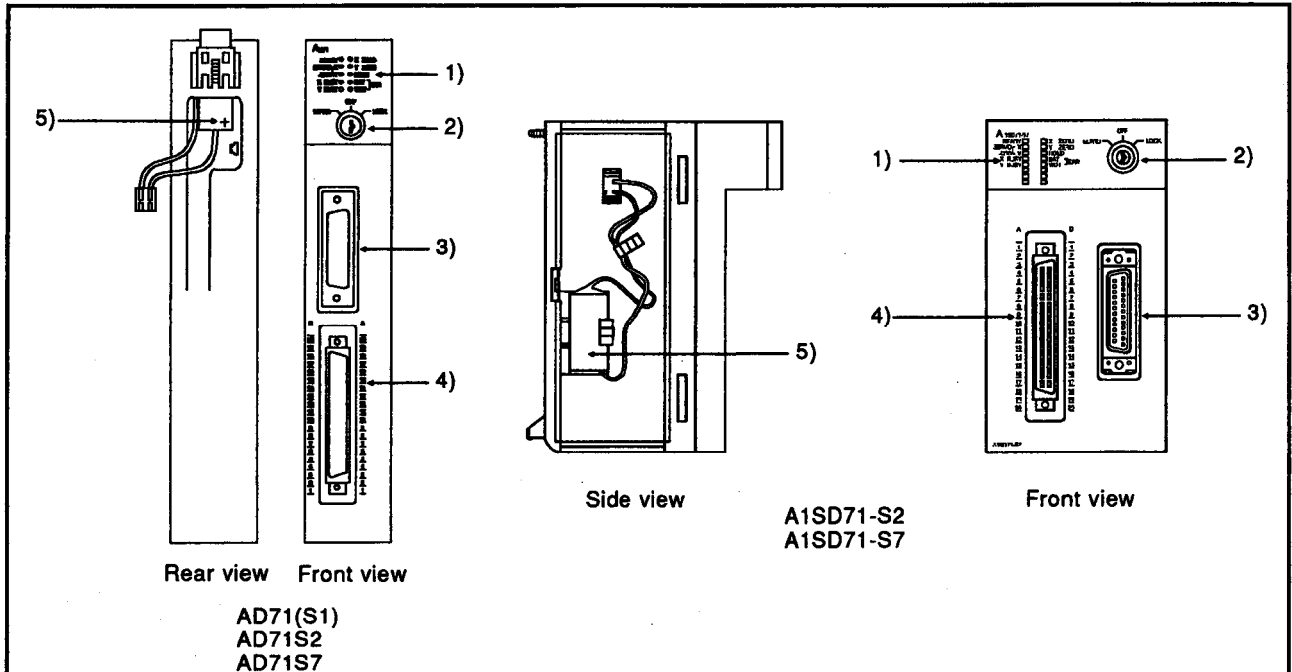

Number	Name	Explanation																		
1)	LED indicator	Indicates operating states and error occurrences.																		
		<table border="1"> <thead> <tr> <th>LED</th> <th>Contents</th> </tr> </thead> <tbody> <tr> <td>READY</td> <td>Lights when the AD71 ready signal (X1) goes ON.</td> </tr> <tr> <td>SERVO <input type="checkbox"/> X - ERR <input type="checkbox"/> Y</td> <td>Lights when the <math>\overline{\text{READY}}</math> signal from the servo unit for the X or Y axis goes OFF.</td> </tr> <tr> <td>X BUSY</td> <td>Lights when the X-axis BUSY signal (X4) goes ON.</td> </tr> <tr> <td>Y BUSY</td> <td>Lights when the Y-axis BUSY signal (X5) goes ON.</td> </tr> <tr> <td>X ZERO</td> <td>Lights when the X-axis zero return request signal (X6) goes ON.</td> </tr> <tr> <td>Y ZERO</td> <td>Lights when the Y-axis zero return request signal (X7) goes ON.</td> </tr> <tr> <td>HOLD</td> <td>Lights when there is an AD71 hardware fault.</td> </tr> <tr> <td>BAT <input type="checkbox"/> WDT <input type="checkbox"/> ERR</td> <td>Lights when the battery error signal (XA) or WDT error signal (X0) goes ON.</td> </tr> </tbody> </table>	LED	Contents	READY	Lights when the AD71 ready signal (X1) goes ON.	SERVO <input type="checkbox"/> X - ERR <input type="checkbox"/> Y	Lights when the $\overline{\text{READY}}$ signal from the servo unit for the X or Y axis goes OFF.	X BUSY	Lights when the X-axis BUSY signal (X4) goes ON.	Y BUSY	Lights when the Y-axis BUSY signal (X5) goes ON.	X ZERO	Lights when the X-axis zero return request signal (X6) goes ON.	Y ZERO	Lights when the Y-axis zero return request signal (X7) goes ON.	HOLD	Lights when there is an AD71 hardware fault.	BAT <input type="checkbox"/> WDT <input type="checkbox"/> ERR	Lights when the battery error signal (XA) or WDT error signal (X0) goes ON.
		LED	Contents																	
		READY	Lights when the AD71 ready signal (X1) goes ON.																	
		SERVO <input type="checkbox"/> X - ERR <input type="checkbox"/> Y	Lights when the $\overline{\text{READY}}$ signal from the servo unit for the X or Y axis goes OFF.																	
		X BUSY	Lights when the X-axis BUSY signal (X4) goes ON.																	
		Y BUSY	Lights when the Y-axis BUSY signal (X5) goes ON.																	
		X ZERO	Lights when the X-axis zero return request signal (X6) goes ON.																	
Y ZERO	Lights when the Y-axis zero return request signal (X7) goes ON.																			
HOLD	Lights when there is an AD71 hardware fault.																			
BAT <input type="checkbox"/> WDT <input type="checkbox"/> ERR	Lights when the battery error signal (XA) or WDT error signal (X0) goes ON.																			
2)	Keyswitches	M.PRO ..... Sets memory protect for the setting data and positioning data areas.																		
		OFF ..... Cancels memory protect for the setting data and positioning data areas.																		
		LOCK ..... Prohibits a pulse chain output from the AD71. (Refer to Section 7 about how of use.)																		
3)	RS-422 connector	Used for connections with a peripheral device such as an A6GPP, A6PHP and AD71TU.																		
4)	40 pin connector	Used for connections with a drive unit.																		
5)	Battery (A6BAT)	For backup of positioning data																		

## 4.3 Battery Connection

The battery backs up the IC-RAM during power failures. The leads are disconnected before shipment to prevent battery drainage. Always connect the battery leads before using the AD71.  
(Refer to Section 9 for details of the timing of battery replacement.)

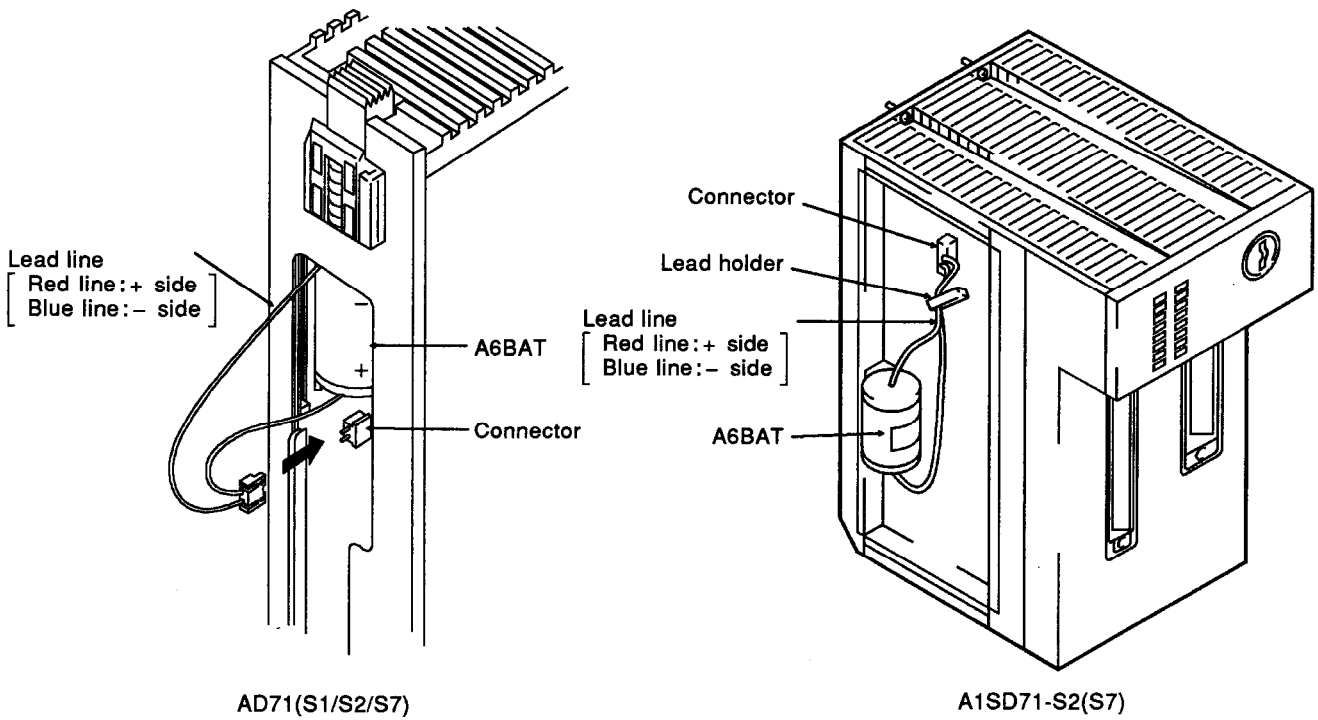

**IMPORTANT**

The components on the printed circuit board may be damaged by static electricity. When handling the printed circuit board:

- 1) Ground all tools, the work bench, etc.
- 2) Do not touch conductive areas or electrical components.



### 5. LOADING AND INSTALLATION

This section explains the methods for loading and installation and the precautions to take to increase system reliability and to use the functions most efficiently.

#### 5.1 Installation Environment

The following installation environments are unsuitable for this equipment.

- (1) Ambient temperature outside the range 0 to 55 °C.
- (2) Ambient humidity outside the range 10 to 90 %RH.
- (3) Excessive condensation (e.g. due to sudden temperature changes)
- (4) Corrosive and/or combustible gasses.
- (5) Excessive amounts of conductive powder such as dust, iron filings, oil mist, salt, or organic solvent.
- (6) Direct exposure to sunlight
- (7) In the vicinity of strong power and magnetic fields.
- (8) Excessive vibration and shock transmitted directly to the main unit.

#### 5.2 Unit Wiring Precautions

When the AD71 is connected to the base (main base unit and extension base), heed the following:

- (1) Do not connect it to the extension base without a power supply module (A5[ ]B/A1S5[ ]B extension base).
- (2) If the board temperature exceeds 55 °C, consider forcible ventilation of the PC CPU board.

## 5.3 Mounting and Removing the Module

This section describes how to mount and remove the AD71.

### 5.3.1 Mounting and removing the AD71(S1/S2/S7)

The procedures for mounting and removing an AD71(S1/S2/S7) type positioning module are shown below.

#### (1) Module mounting

Follow the steps indicated below to mount the module:

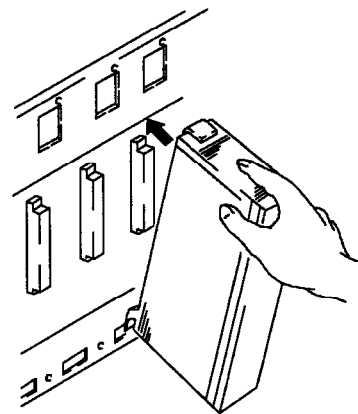
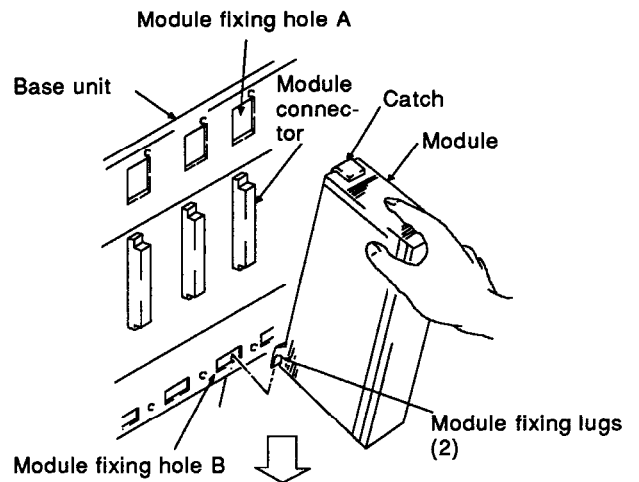
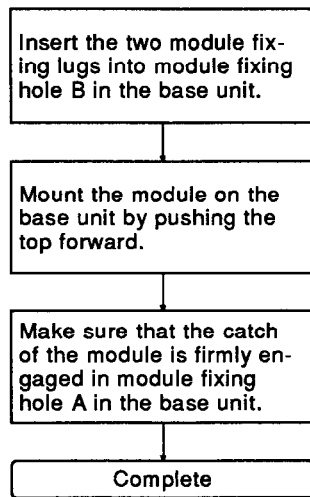

#### POINTS

- (1) Secure the module with the module fixing lugs inserted in module fixing hole B. Do not mount the module by force while they are not inserted since the module connector pins may be bent, or the module itself may be damaged.
- (2) To use the module in a location where it may be exposed to vibration or shock, screw the module to the base unit. Prepare M4 x 0.7 x 12 screws. Refer to the figure to the right for the method.

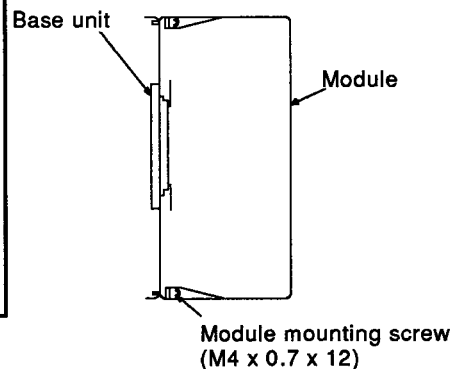

## (2) Removing the module

Follow the steps below to remove the module:

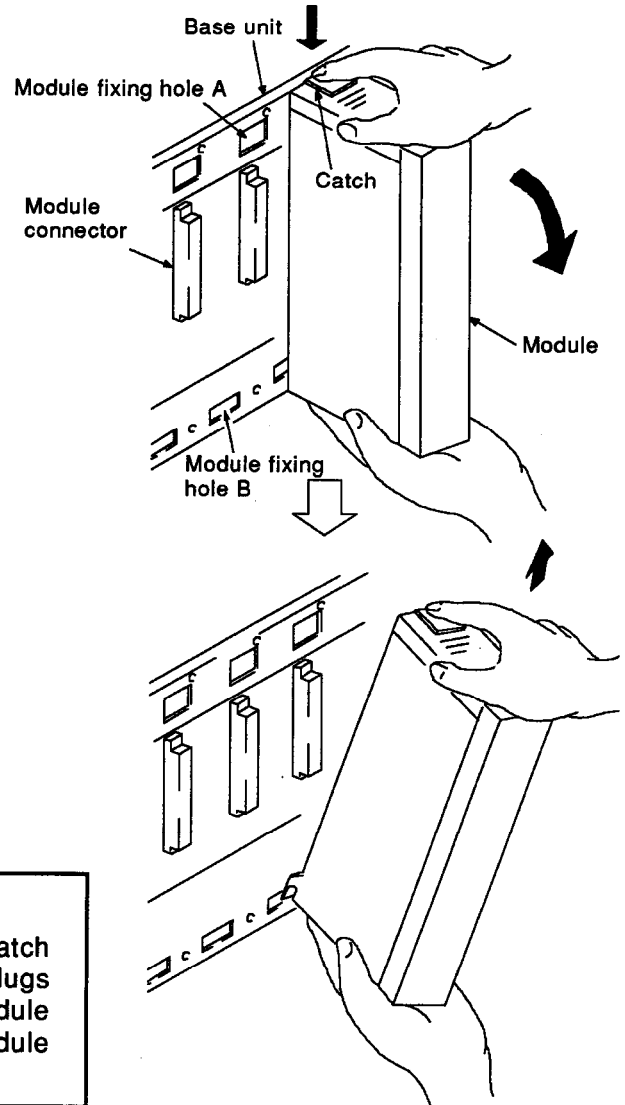
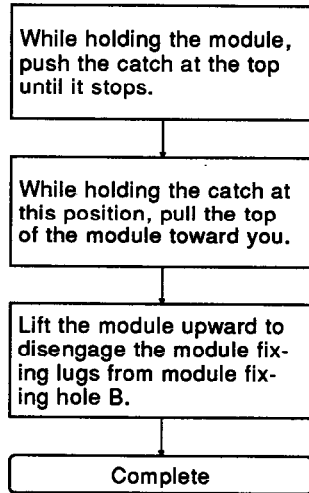

### POINT

When removing the module, first disengage the catch from module fixing hole A, then the module fixing lugs from module fixing hole B. Do not remove the module by force. This could damage the catch or module fixing lugs.

## 5.3.2 Mounting and removing the A1SD71-S2(S7)

The procedures for mounting and removing an A1SD71-S2(S7) type positioning module are shown below.

### (1) Mounting the module

Follow the steps indicated below to mount the module:

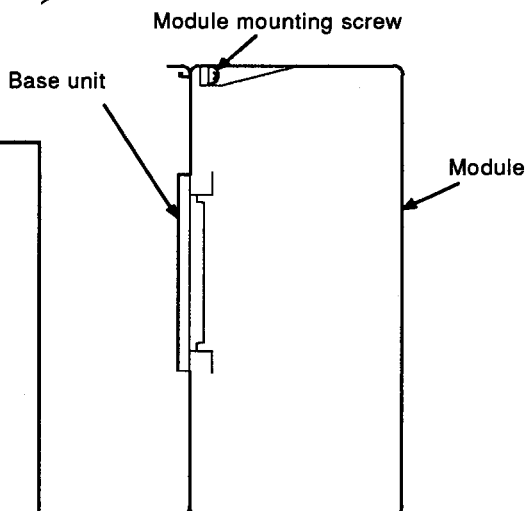
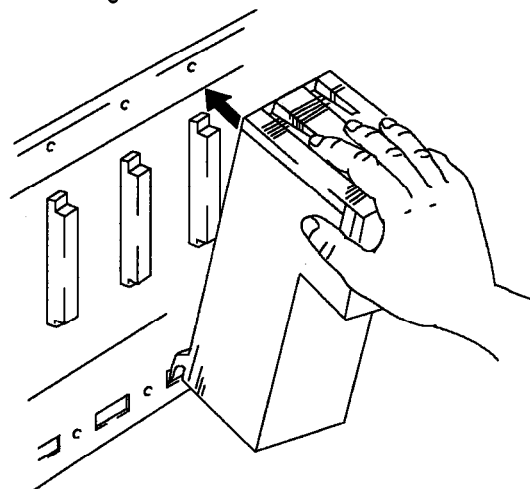
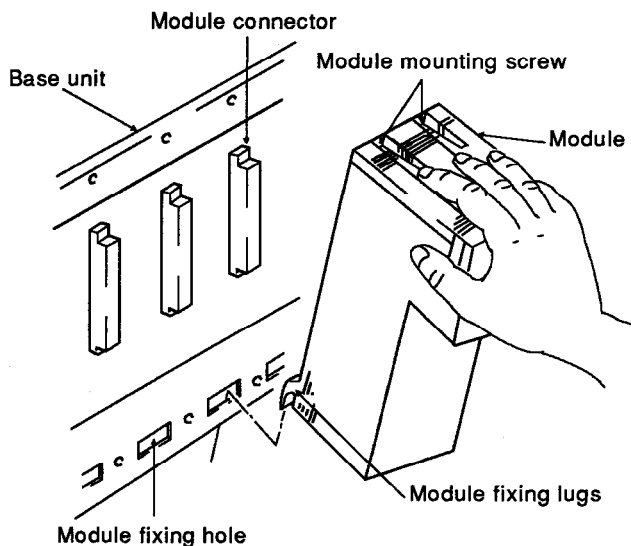
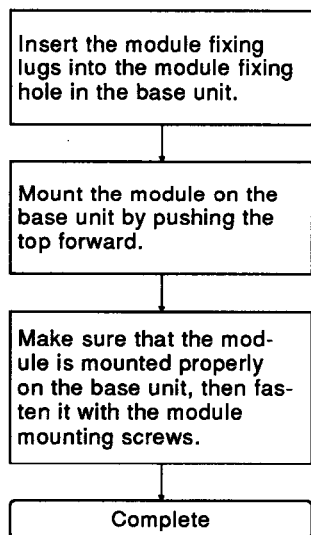

### POINTS

- (1) Fasten the module with the module mounting screws after making sure that the module fixing lugs are engaged in the module fixing hole. Do not mount the module by force while they are not inserted since the module connector pins may be bent, or the module itself may be damaged.
- (2) Turn off the power before mounting or removing the module.

## (2) Removing the module

Follow the steps below to remove the module:

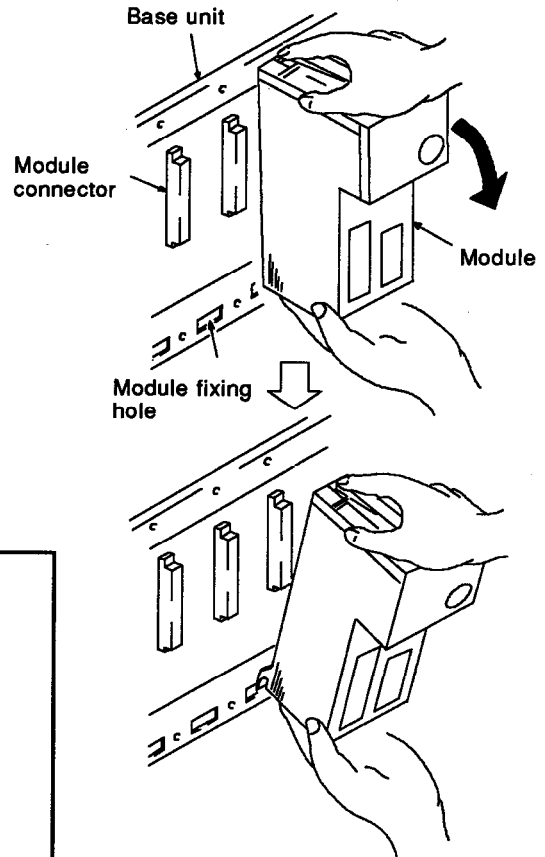
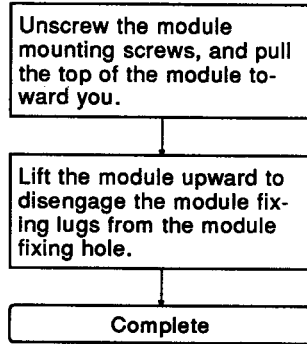

### POINTS

- (1) When removing the module, first unscrew the module mounting screws, then disengage the module fixing lugs from the module fixing hole. Do not remove the module by force: this could damage the module fixing lugs.
- (2) Turn off the power before mounting or removing the module.

### 5.4 Wiring

The following describes (a) precautions when doing wiring between the AD71 and external devices, and (b) how to use the external wiring connector.

#### 5.4.1 Wiring precautions

Precautions when doing wiring between the AD71 and external devices (including a drive unit) are described below. A connection examples is given in Appendix 3.

(1) Length of connection cable between the AD71 and drive unit

The length of the connection cable between the AD71 and the drive unit is generally 1 to 3 meters (3 to 10 feet). However, the distance depends on the drive unit specifications.

Make sure to confirm the correct specifications.

(2) I/O signal wiring

- Do not put the connection cable next to the power or main circuit cable.
- If the connection cable has to be brought close to them, either separate the ducts or use conduct.
- If the cables must be bundled together, use a batch-sealed cable and ground them on the PC CPU side.
- If the cables are wired with conduct, make sure to ground the conduct.
- If the connection cable is too long, and is too close to a main circuit cable, noise may cause a malfunction.

# 5. LOADING AND INSTALLATION

Examples (bad example at top, good example at bottom)

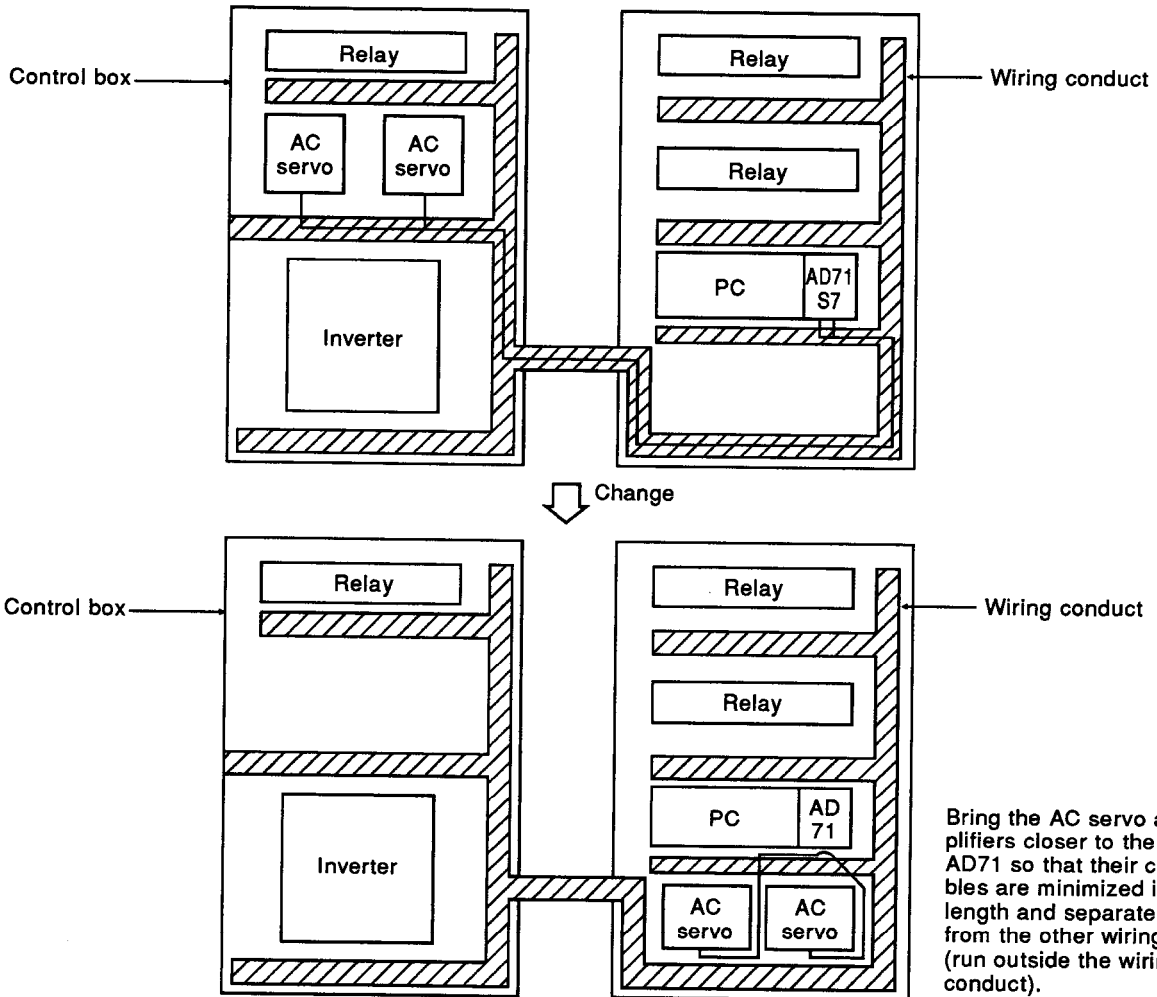

**REMARK**

When there is a lot of noise between the AD71 and servo amplifier, provide wiring from the pulse string output terminal from the AD71 using shielded twisted-pair cable that is different from other shielded cables.

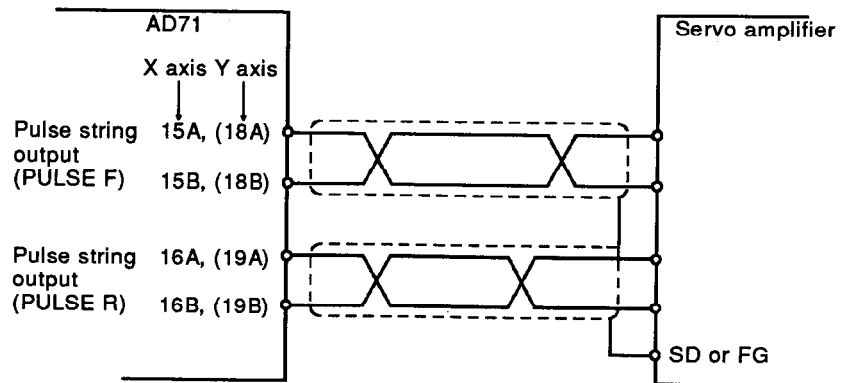

(3) 24 VDC wiring notes

When a servo drive unit has a built-in power supply of 24 VDC, a wraparound circuit is made by the state of a power supply. A malfunction will occur if a separate power supply is supplied externally. Therefore, do not use the built-in power supply and external power supply together.

[Wraparound circuit]

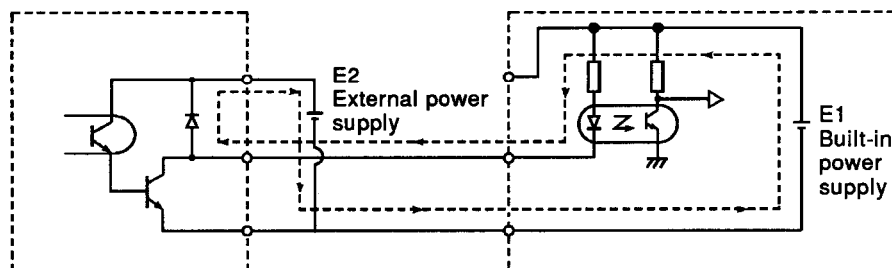

$E1 > E2$

Even if the pulse output of AD71S7 is OFF, the power supply flows in a servo unit pulse input line.



### 5.4.2 Connecting external wiring

The AD71 has the following connectors:

When connecting an electric wire, disassemble as shown in Fig. 5.1.

The disassembly and assembly procedures are as follows:

- 1) Loosen the four screws, and remove them.
  - 2) Open the cover from the connector side.
  - 3) Connect the electric wire (refer to Section 5.4.3(1) to (3)).
  - 4) Put connectors into the cover.
  - 5) Pull open the fixed screws.
  - 6) Put the covers together.
  - 7) Fasten the four screws. Use longer screws for cable clamping.
- Always keep track of small screws and nuts when disassembling.

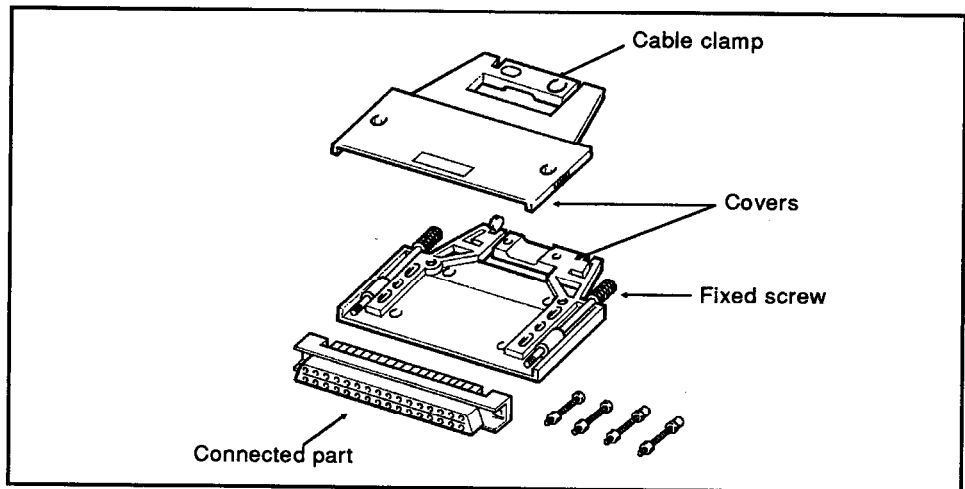

Fig. 5.1 Connector

### 5.4.3 Connecting electric wiring

Connector pin wiring is shown in Fig. 5.2. Connect in accordance with the I/O numbers (refer to Section 3.8.2).

- (1) Use 0.3 mm<sup>2</sup> or less wires. Thicker wires cannot pass through the cable clamps.
- (2) Solder the wires to the pins. Remove electric wire insulation carefully. Be careful not to cause a short circuit. Wires should be threaded through an insulating tube.
- (3) Secure the electric wire in the cable clamp of a cover. When there are several connecting electric wires, wrap them together with tape.

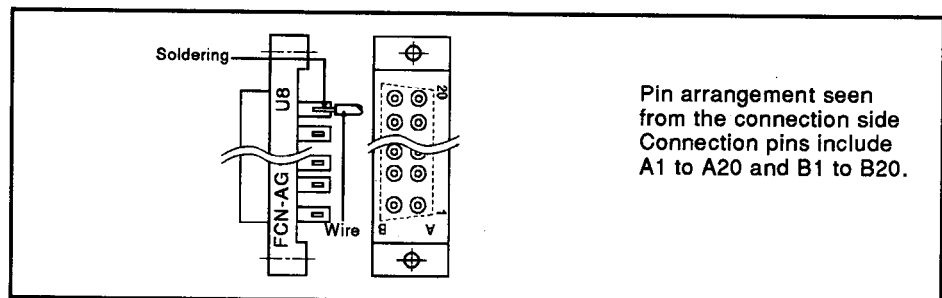

Fig. 5.2 Connection

## 5.4.4 Compliance with EMC and low-voltage directives

To comply with EMC and low-voltage directives, use shielded cables and AD75CK cable clamp (made by Mitsubishi Electric) to ground to the panel.

### 1) When using cable of within 2m for wiring

- Ground the shield part of the external device connection cable with a cable clamp. (Ground the shield part at the point nearest to the external device connection connector of the AD71 / A1SD71.)
- Wire the external device connection cable with the drive unit and external device at the shortest distance.
- Install the drive unit within the same enclosure.

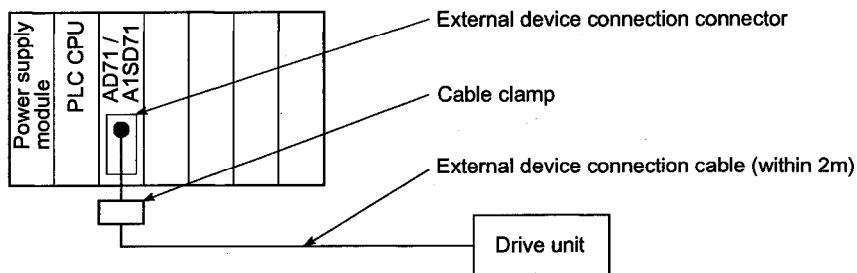

### 2) When using cable of more than 2m to within 10m for wiring

- Ground the shield part of the external device connection cable with a cable clamp. (Ground the shield part at the point nearest to the external device connection connector of the AD71 / A1SD71.)
- Wire the external device connection cable with the drive unit and external device at the shortest distance.
- Fit a ferrite core.

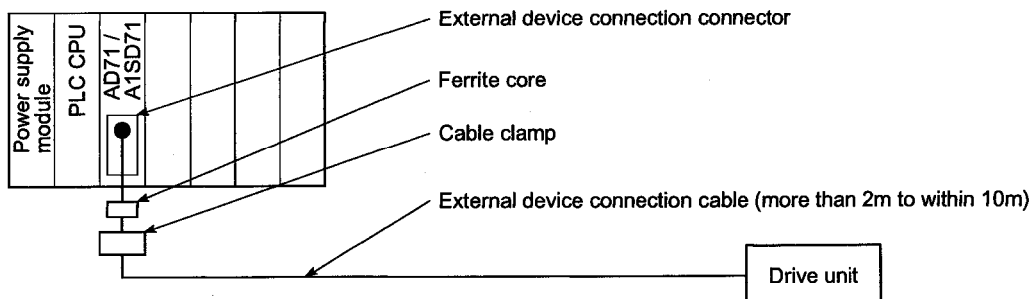

### 3) Ferrite core, cable clamp model names

- Cable clamp  
Model name: AD75CK (Mitsubishi Electric make)
- Ferrite core  
Model name: ZCAT3035-1330 (TDK make ferrite core)

Cable length	Product to be arranged	Required quantity	
		1 axis	2 axes
Within 2m	AD75CK	1	1
More than 2m to within 10m	AD75CK	1	1
	ZCAT3035-1330	1	2

## 4) Cable clamp fitting position and shielded cable grounding method

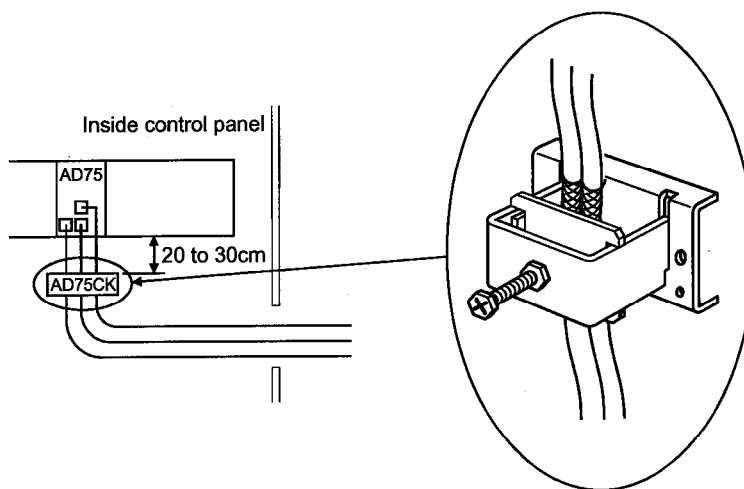

[How to ground shielded cable using AD75CK]

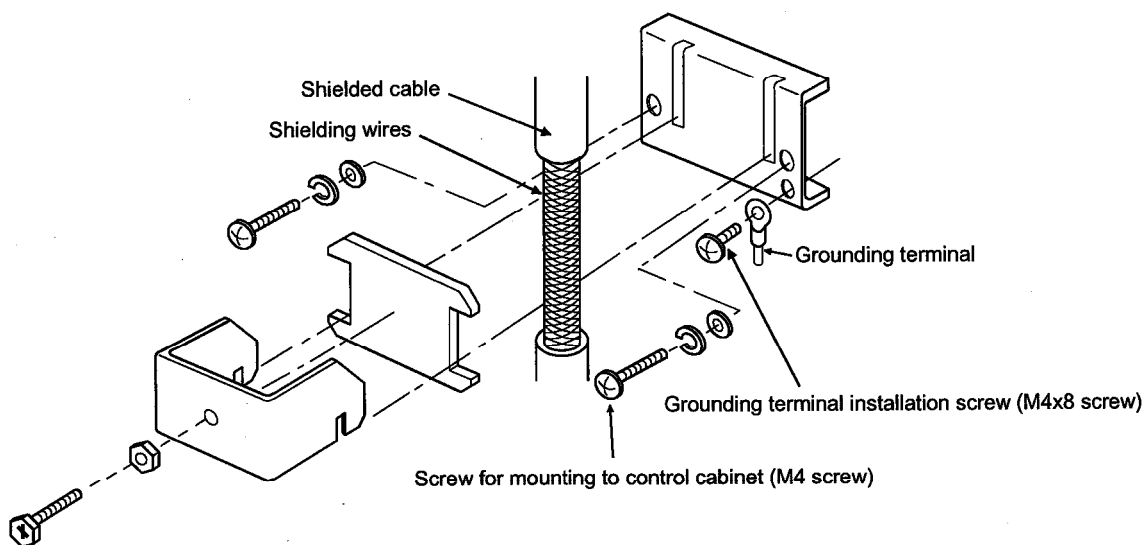

AD75CK can ground up to four shielded cables having about 7 mm or smaller outside diameters. (For details, refer to AD75CK cable clamp operation manual <IB-68682>.)

6. PROGRAMMING

6.1 Program Creation

6.1.1 Program composition

AD71 programs are usually incorporated in an overall program. Programs are classified as follows, and a program example is shown.

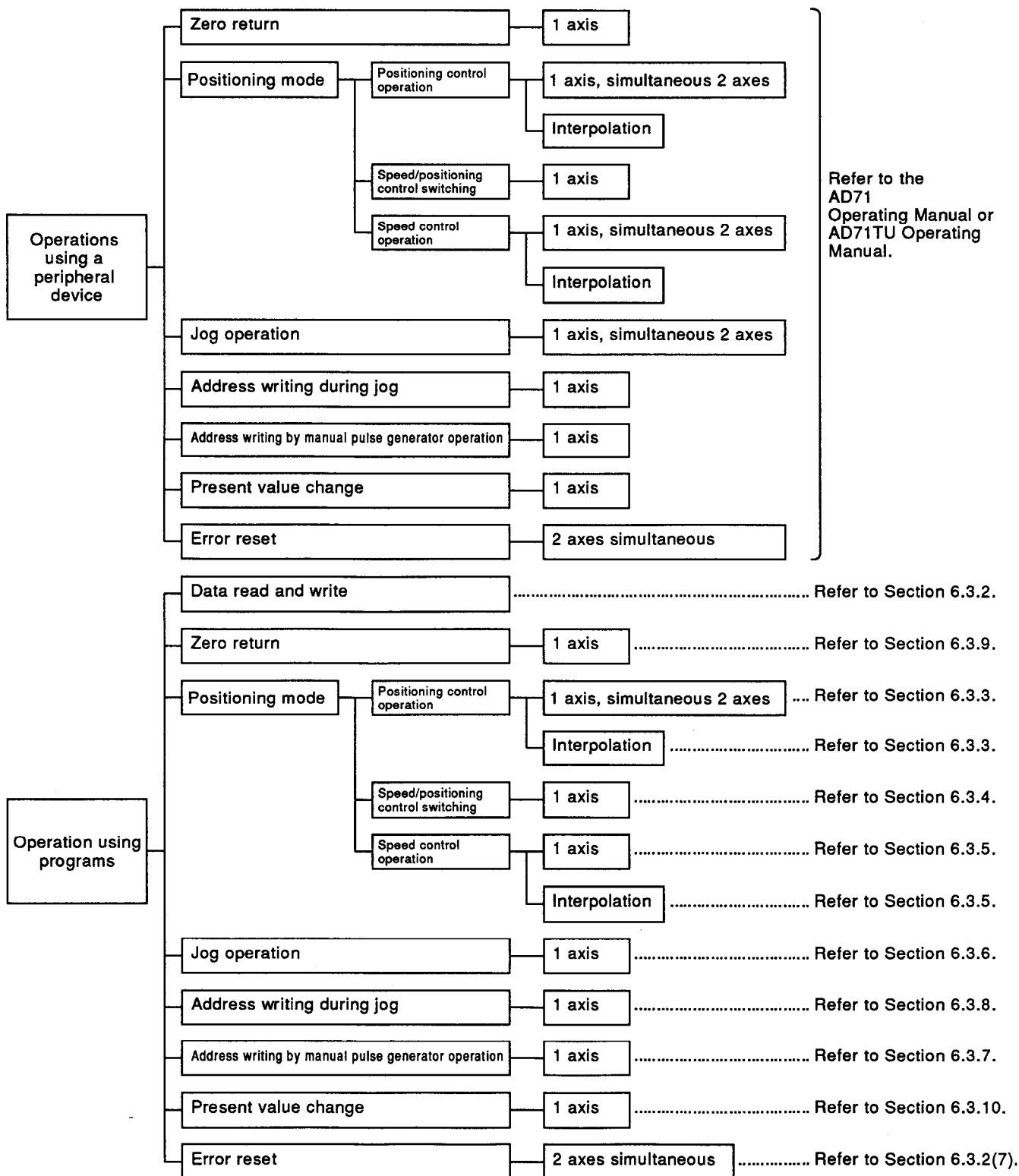

**REMARK**

Unless otherwise indicated, the sequence programs in this section use the I/O numbers (X, Y) when the AD71 is loaded in the following I/O slots:

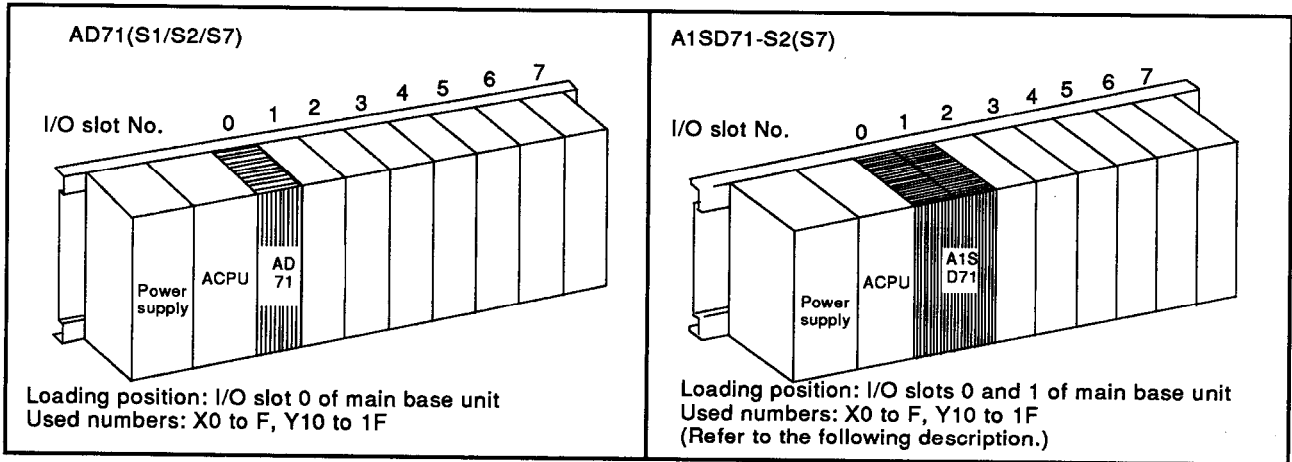

**Fig. 6.1 Loading Slots for the Following Program Example**

[I/O numbers when an A1SD71-S2(S7) is used]

There are 48 A1SD71-S2(S7) input/output points and the module occupies two slots. Therefore, execute I/O allocations using the GPP function as follows:

- First half slot . . . . . Empty slot :16 points
- Second half slot . . . . . Special-function module :32 points

By specifying the 16 points of the first half slot as "vacant slot, 0 points" in I/O allocation using the GPP function, these points can be saved.

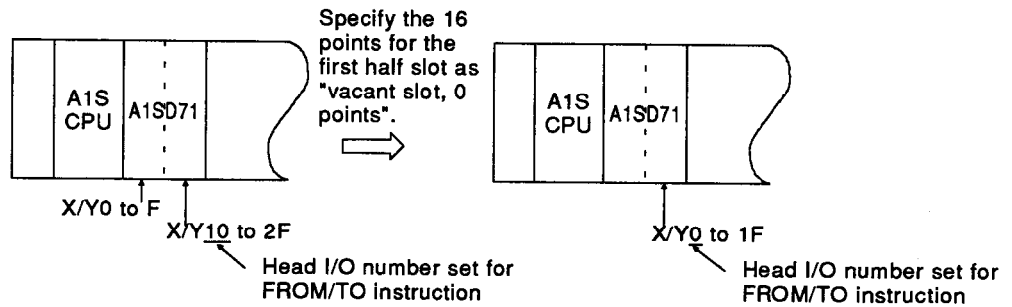

When the first half slot is specified as "vacant slot, 0 points", the head I/O number at which FROM/TO instructions with respect to the A1SD71 will be executed is the same as that allocated to the A1SD71.

This section shows the I/O numbers when the A1SD71 is loaded in slots 0 and 1 and the first half slot is specified as "vacant slot, 0 points" in I/O allocation using the GPP function.

6.1.2 Precautions when creating programs

(1) Sequence program conditions

Use the AD71 to provide the program shown in Fig. 6.2-1 to the system.

(a) Program for AD71S2 or A1SD71-S2

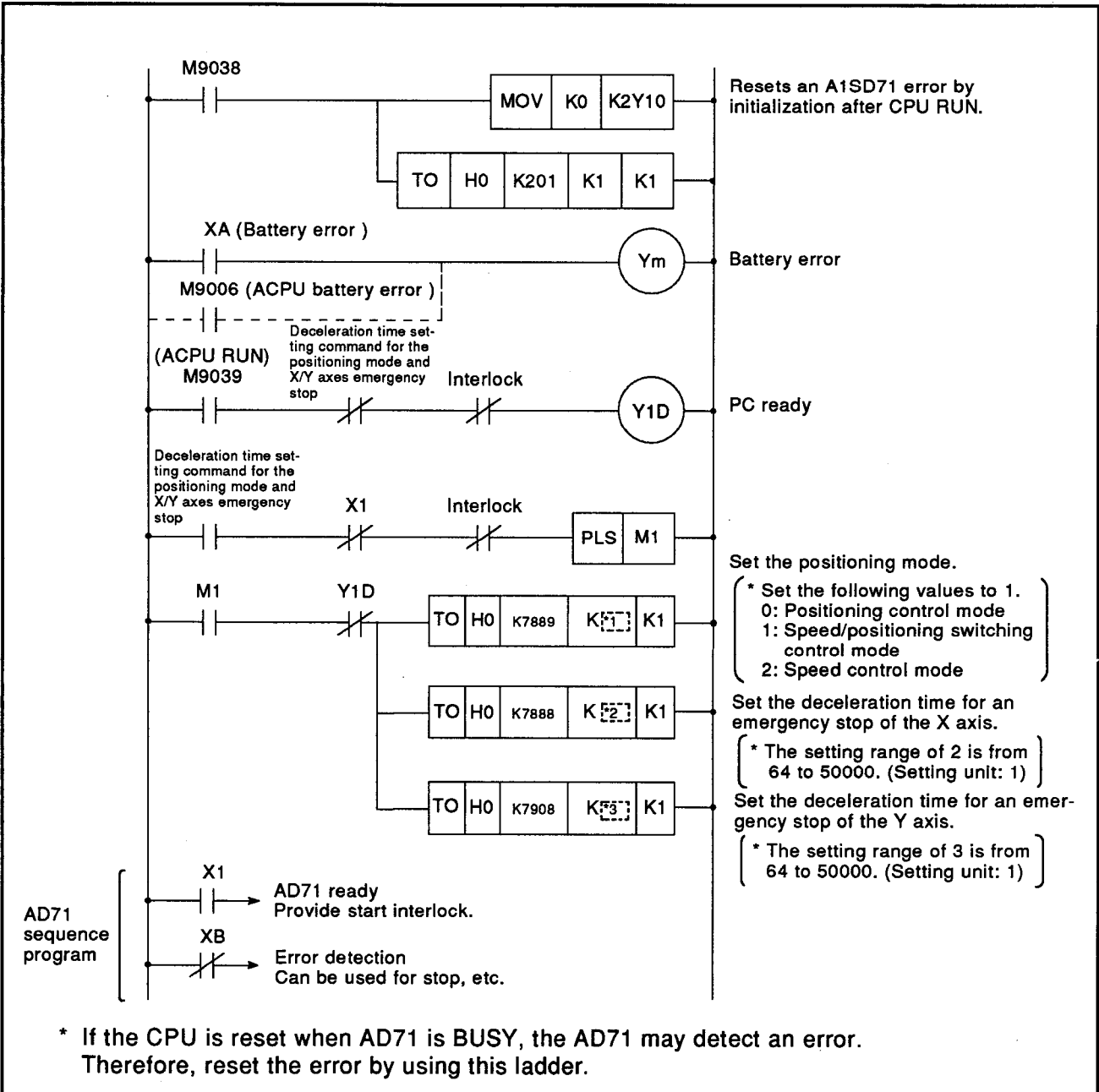

Fig. 6.2-1 Necessary Program for AD71S2 or A1SD71-S2

(b) Program for AD71(S1/S7) or A1SD71-S7

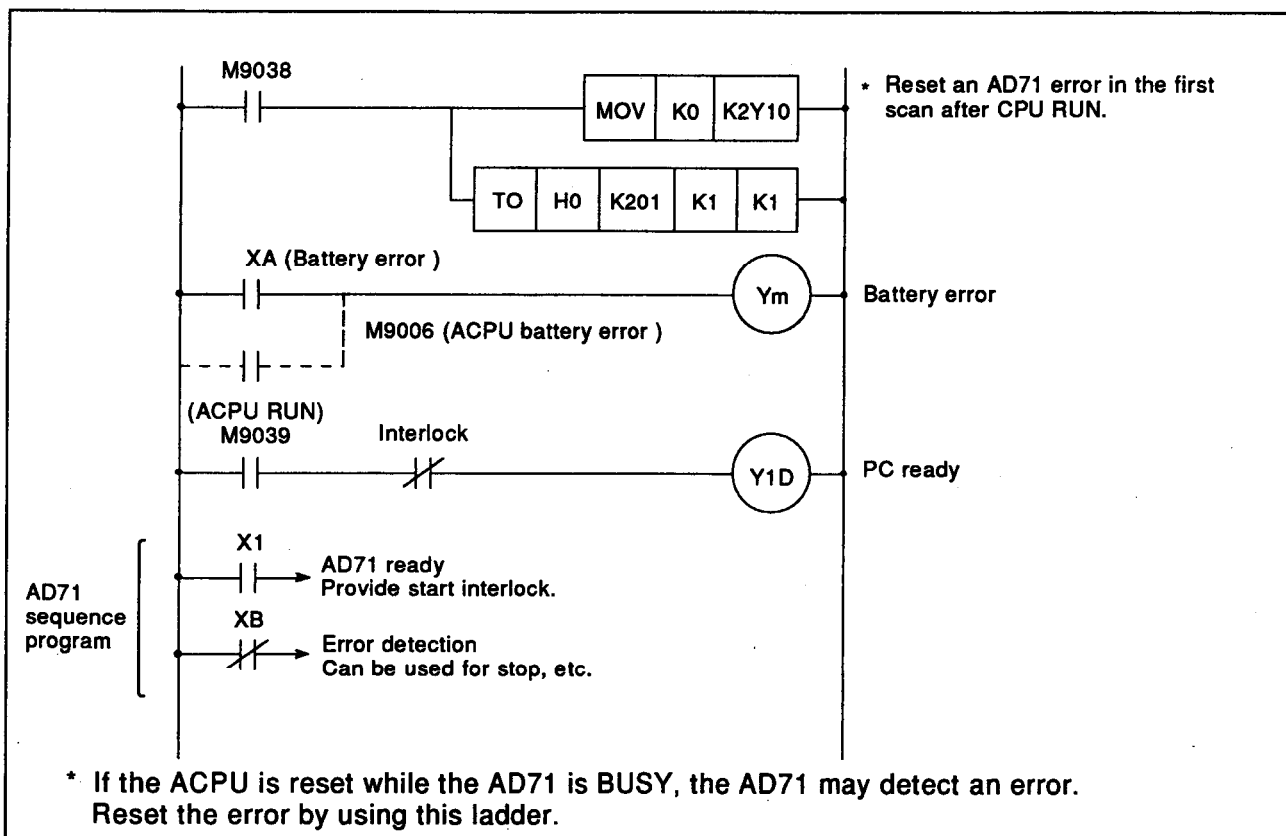

Fig. 6.2-2 Necessary Program for AD71(S1/S2) or A1SD71-S7

(2) PC ready reset

When an error is detected in the sequence program, create a program so that the PC ready signal (Y1D) is reset by detecting the error.

(3) AD71 ready

Following time (t) is needed to turn ON the AD71 ready signal (X1) after checking parameter and zero return data when a PC ready signal (Y1D) is switched from OFF to ON.

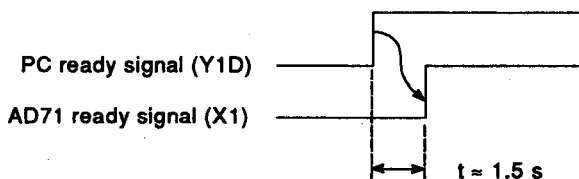

When switching the positioning mode, the PC ready signal (Y1D) must be turned OFF. (When the PC ready signal (Y1D) goes OFF, positioning mode data is written to the AD71.)

Therefore, after switching the positioning mode, the positioning start time will be delayed.

(4) Zero return

Be sure to execute zero return when turning the power ON. (The present values of the positioning module cannot be guaranteed when turning the power ON.)

- (5) Limit switch for near-point dog  
Use a limit switch with high contact reliability. If the near-point dog signal is not input during zero return, the movement continues at the zero return speed.
- (6) Overrun processing  
Overrun is prevented in the upper/lower strokes by limit setting. However, this applies when the AD71 is operating normally. For safety, Mitsubishi recommends setting a marginal limit switch and external circuit that turns OFF power to the motor power when the limit switch goes ON.
- (7) Emergency stop  
The STOP input signal is a positioning deceleration stop signal which cannot be used for an emergency stop. Stop the drive unit by external contact in the case of an emergency stop.
- (8) Upper/lower stroke limit values  
Confirm whether correct upper/lower stroke limit values have been set.
- (9) Speed limit value  
Confirm whether a proper speed limit has been set to a parameter.
- (10) JOG speed  
Do not set the high speed at the JOG speed.  
Execute operations at the low JOG speed.
- (11) Speed during interpolation operations  
The speed during interpolation operations is decided with the X and Y axes. Therefore, set the speed of both axes correctly so that either axis operates at the setting speed or lower.
- (12) Programming for AOJ2CPU  
The program includes some commands which cannot be used for the AOJ2CPU, such as TOP and FROMP. Change these commands as follows. (For details, refer to the AOJ2CPU Programming Manual.)

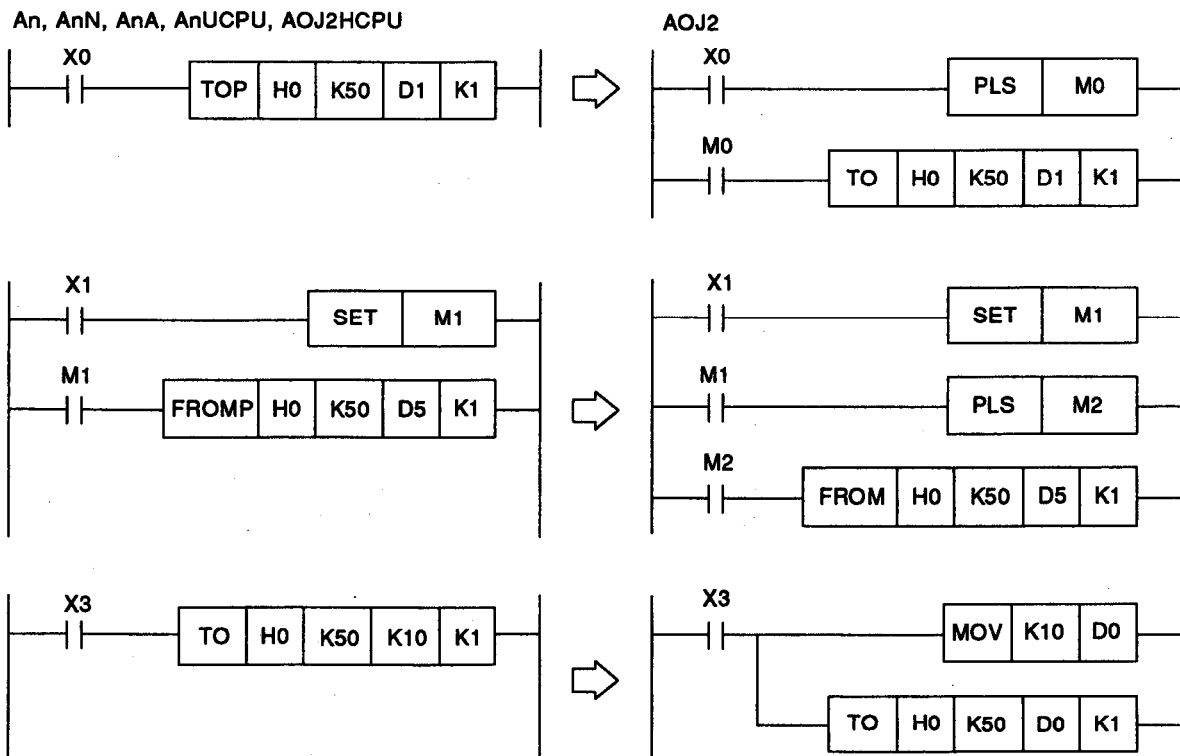



### 6.2 Operations Using a Peripheral Device

A1SD71 positioning operations can be executed in the test mode using a peripheral device. Operating conditions are as follows:

- (1) Install a peripheral device in the AD71.
- (2) Operations are enabled independently of the ON/OFF state of the PC ready signal (Y1D) and AD71 ready signal (X1).
- (3) Data cannot be read and written from/to the peripheral device during BUSY when operating a peripheral device in the test mode.
- (4) ON/OFF of the M code will be ignored. (Buffer memory M code area (X axis: 46, Y axis: 346) is cleared.)

## 6.3 Programming

### 6.3.1 Data read and write precautions

- (1) It is advisable to read and write set data with a peripheral device. Data reading and writing with a sequence program is a very complicated operation and increases the scan time, because it requires numerous programs and devices.
- (2) The parameters and zero return data is checked at power on and when the PC ready signal (Y1D) changes from OFF to ON.
- (3) Positioning data is checked immediately before it is processed. Any error will cause the error signal (XB) to switch on and, in most cases, positioning to stop.

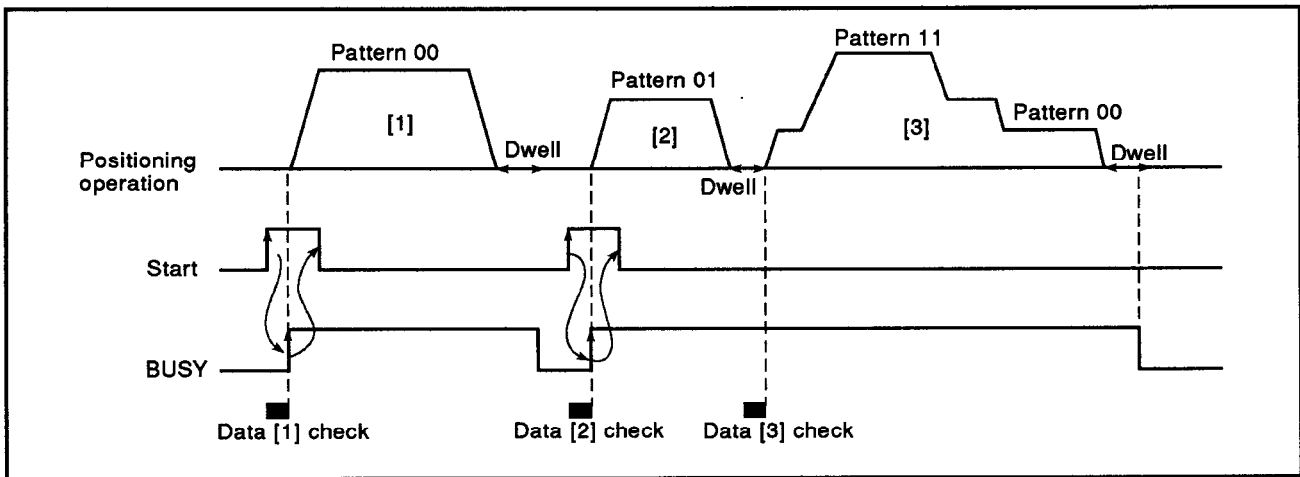

**Fig. 6.3 Positioning Data Check**

An error is flagged if the total distance requested exceeds the upper (or lower) stroke limit when incremental position addressing is used.

6.3.2 Data communication with PC program

(1) Read and write instructions

(a) Read from AD71

FROM instruction: Also FROMP, DFRO, and DFROP.

[Format]

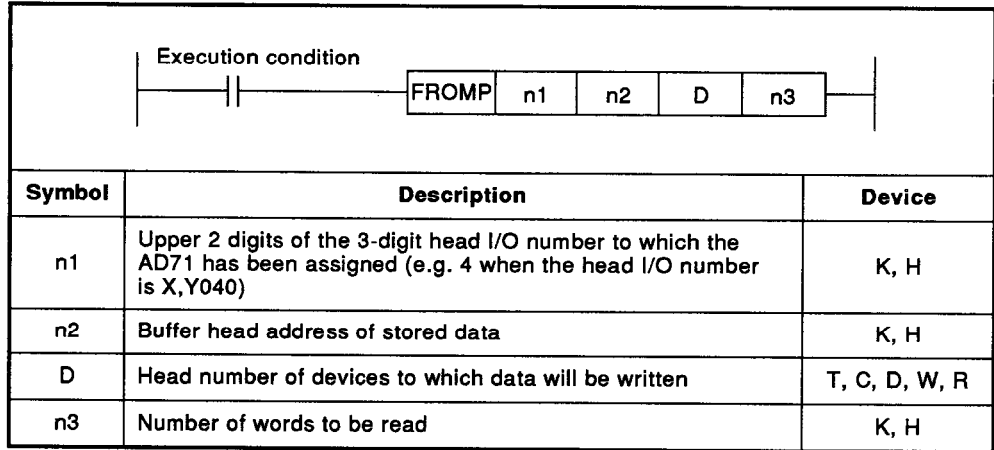

Fig. 6.4 Read Instruction FROM

Example: To read one word from buffer memory address 600 (X axis output speed) to D2 with the AD71 assigned to X130 to X13F and Y140 to Y14F.

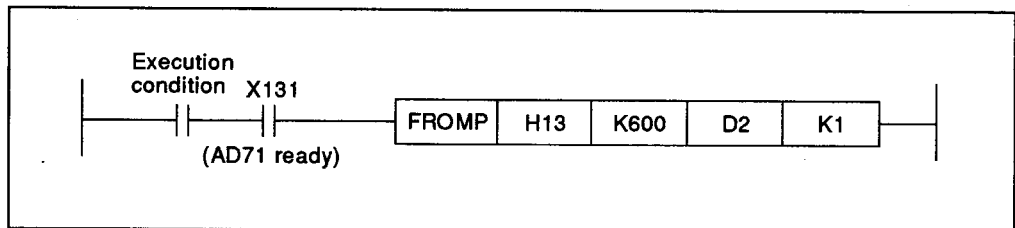

Fig. 6.5 Read Example

(b) Write to AD71

TO instruction: Also TOP, DTO, and DTOP.

[Format]

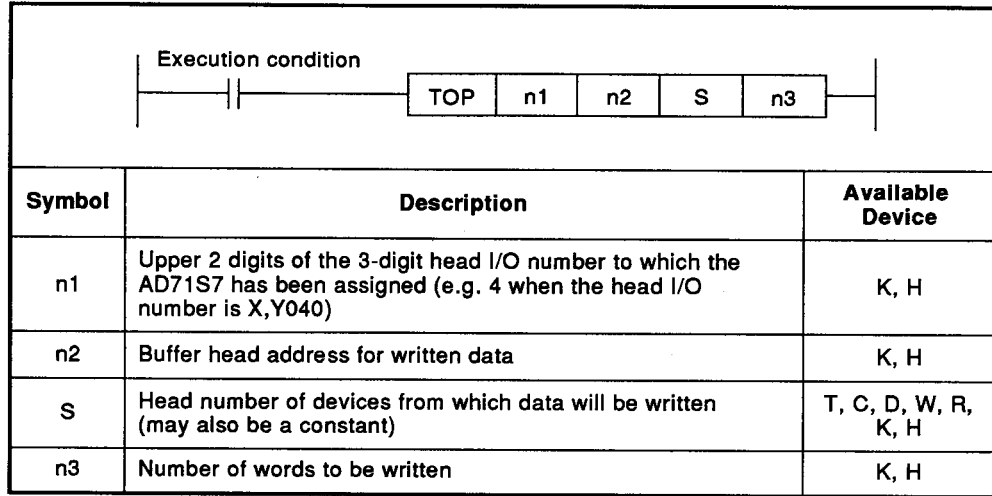

Fig. 6.6 Write Instruction TO

Example: To write positioning information to buffer memory address 3872, with the AD71 assigned to X20 to X2F and Y30 to 3F.

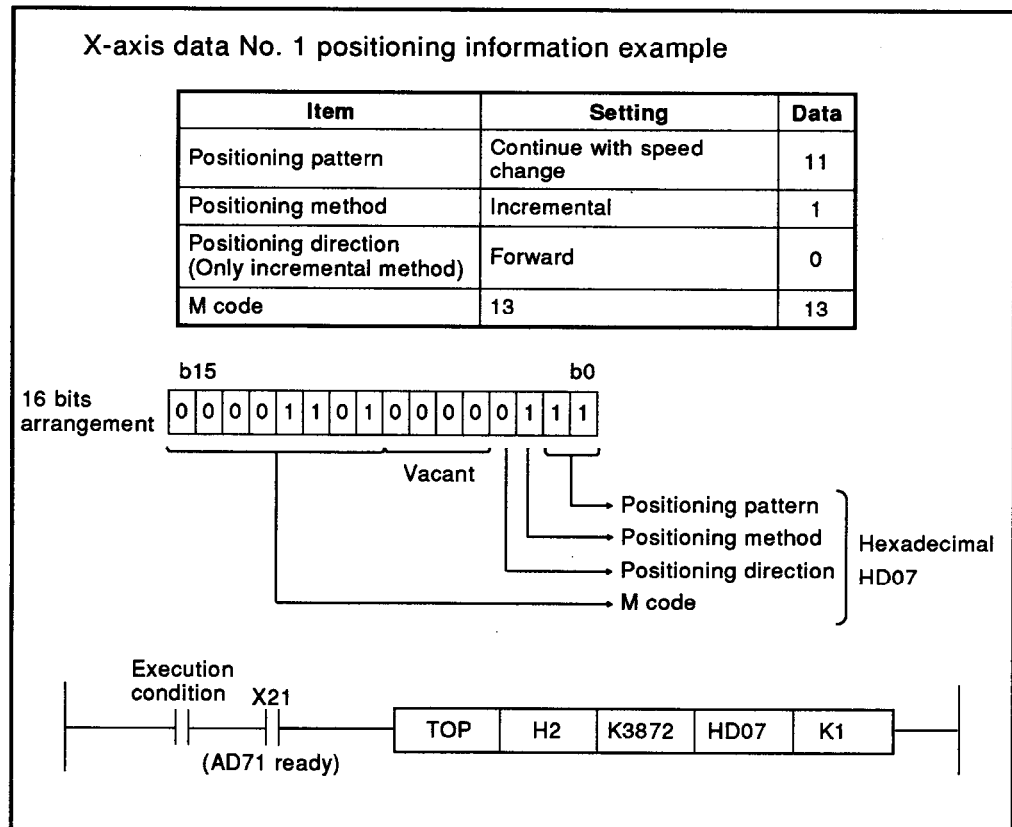
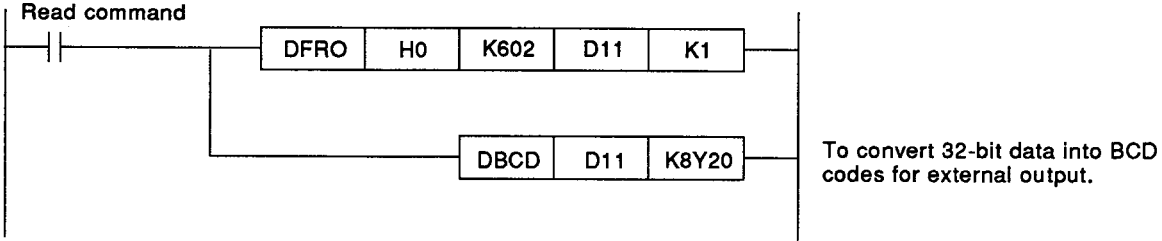

Fig. 6.7 Write Example

**POINT**

A maximum of 2,000 words may be read or written using one instruction. Note however that in this case the watch dog timer (WDT) may need to be reset.

(2) Present value read program example

<b>[Example]</b>	Indication of X axis present value									
<b>[Notes]</b>	(1) During positioning, the present value as stored in the AD71 buffer memory lags behind the actual value by about 0.1 seconds. (2) The present value is two words long.									
<b>[Data transfer]</b>	<div style="display: flex; justify-content: space-around; align-items: center;"> <div style="text-align: center;"> <p>CPU data register</p> <table border="1" style="margin: 0 auto; border-collapse: collapse;"> <tr><td style="padding: 2px 10px;">D11</td></tr> <tr><td style="padding: 2px 10px;">D12</td></tr> <tr><td style="padding: 2px 10px;"> </td></tr> <tr><td style="padding: 2px 10px;"> </td></tr> </table> <p>Written to D11 and 12 (32 bits)</p> </div> <div style="font-size: 2em; margin: 0 20px;">←</div> <div style="text-align: center;"> <p>AD71 buffer memory</p> <table border="1" style="margin: 0 auto; border-collapse: collapse;"> <tr><td style="padding: 2px 10px;">Address</td></tr> <tr><td style="padding: 2px 10px;">602</td></tr> <tr><td style="padding: 2px 10px;">603</td></tr> <tr><td style="padding: 2px 10px;">X axis present value</td></tr> <tr><td style="padding: 2px 10px;"> </td></tr> </table> </div> </div>	D11	D12			Address	602	603	X axis present value	
D11										
D12										
Address										
602										
603										
X axis present value										
<b>[Program]</b>										

(3) Speed read program example while BUSY

<b>[Example]</b>	Y axis speed read																	
<b>[Note]</b>	None																	
<b>[Data transfer]</b>	<div style="display: flex; justify-content: space-around; align-items: center;"> <div style="text-align: center;"> <p>ACPU data register</p> <table border="1" style="border-collapse: collapse; width: 100px; height: 100px;"> <tr><td> </td></tr> <tr><td> </td></tr> <tr><td style="text-align: center;">D14</td></tr> <tr><td> </td></tr> <tr><td> </td></tr> </table> <p>Stored into D14 (16 bits)</p> </div> <div style="font-size: 2em; margin: 0 20px;">←</div> <div style="text-align: center;"> <p>AD71 buffer memory</p> <table border="1" style="border-collapse: collapse; width: 100px; height: 100px;"> <thead> <tr> <th style="width: 30px;">Address</th> <th> </th> </tr> </thead> <tbody> <tr> <td style="text-align: center;">600</td> <td>X-axis output speed</td> </tr> <tr> <td style="text-align: center;">601</td> <td>Y-axis output speed</td> </tr> <tr><td> </td><td> </td></tr> <tr><td> </td><td> </td></tr> <tr><td> </td><td> </td></tr> </tbody> </table> </div> </div>			D14			Address		600	X-axis output speed	601	Y-axis output speed						
D14																		
Address																		
600	X-axis output speed																	
601	Y-axis output speed																	
<b>[Program]</b>	<pre> graph LR     SR[Speed read] --- COIL[FROMP H0 K601 D14 K1]     </pre>																	

(4) Data number and pointer write program example

<b>[Example]</b>	X axis data number and pointer write													
<b>[Note]</b>	The relevant axis must not be BUSY.													
<b>[Data transfer]</b>	<div style="display: flex; justify-content: space-around; align-items: flex-start;"> <div style="text-align: left;"> <p>1st point start data :No. 1</p> <p>2nd point { start data :No. 13 start axis :X axis</p> <p>Pointer : 1</p> </div> <div style="border: 1px solid black; padding: 5px; text-align: center;"> <p>ACPU data register</p> <table border="1" style="margin: auto;"> <tr><td style="width: 20px;">D35</td></tr> <tr><td style="width: 20px;">D36</td></tr> <tr><td style="width: 20px;">D37</td></tr> </table> </div> <div style="font-size: 2em; margin: 0 10px;">➔</div> <div style="text-align: right;"> <p>AD71 buffer memory</p> <table border="1" style="margin: auto;"> <tr><td style="width: 20px;">Address</td><td style="width: 20px;">0</td></tr> <tr><td></td><td>1</td></tr> <tr><td></td><td>2</td></tr> <tr><td colspan="2" style="text-align: center;">⋮</td></tr> <tr><td></td><td>39</td></tr> </table> </div> </div>	D35	D36	D37	Address	0		1		2	⋮			39
D35														
D36														
D37														
Address	0													
	1													
	2													
⋮														
	39													
<b>[Program]</b>	<p style="text-align: center;">Example of pre-storing data in each device</p> <div style="display: flex; align-items: center;"> <div style="flex: 1;"> <p>Write (X axis BUSY) command X14</p> </div> <div style="flex: 1; padding-left: 20px;"> <p>Stores 1st point start data No. into D35.</p> <p>Stores 2nd point start data No. into D36.</p> <p>Stores 2nd point start axis (X axis = 01) into D37.</p> </div> </div>													

# 6. PROGRAMMING

MELSEC-A

## (5) Parameter and zero return data write program example

[Example] X axis parameter write - Assume that the parameters are already in D16 to 31

[Note] When writing parameters and zero return data, the PC ready signal (Y1D) should be off.

[Data transfer]

ACPU data register (Data already written)	
Parameter information	D16
Travel per pulse	D17
Speed limit value	D18
Jog speed limit value	D19
Acceleration and deceleration times	D20
Backlash compensation	D21
Upper stroke limit	D22
	D23
Lower stroke limit	D24
	D25
Error compensation	D26
	D27
Travel per inching input	D28
	D29
Starting bias speed	D30
Positioning complete signal output duration	D31

AD71 buffer memory	
Address	7872
	7873
	7874
	7875
	7876
	7877
	7878
	7879
	7880
	7881
	7882
	7883
	7884
	7885
	7886
	7887

[Program]



(6) Speed change program example while BUSY

[Example] To change X axis positioning speed to 2,000 (20,000 mm/min).

[Note] Speed cannot be changed during interpolation.

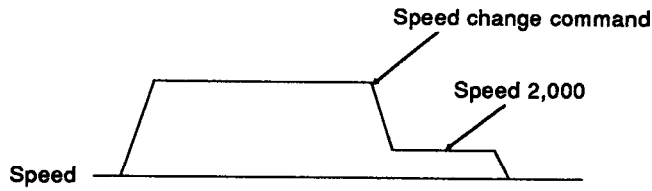

[Data transfer]

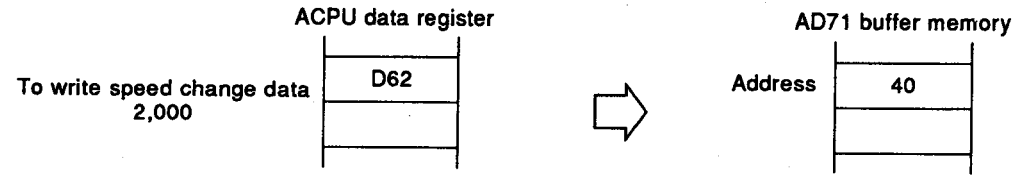

[Program]

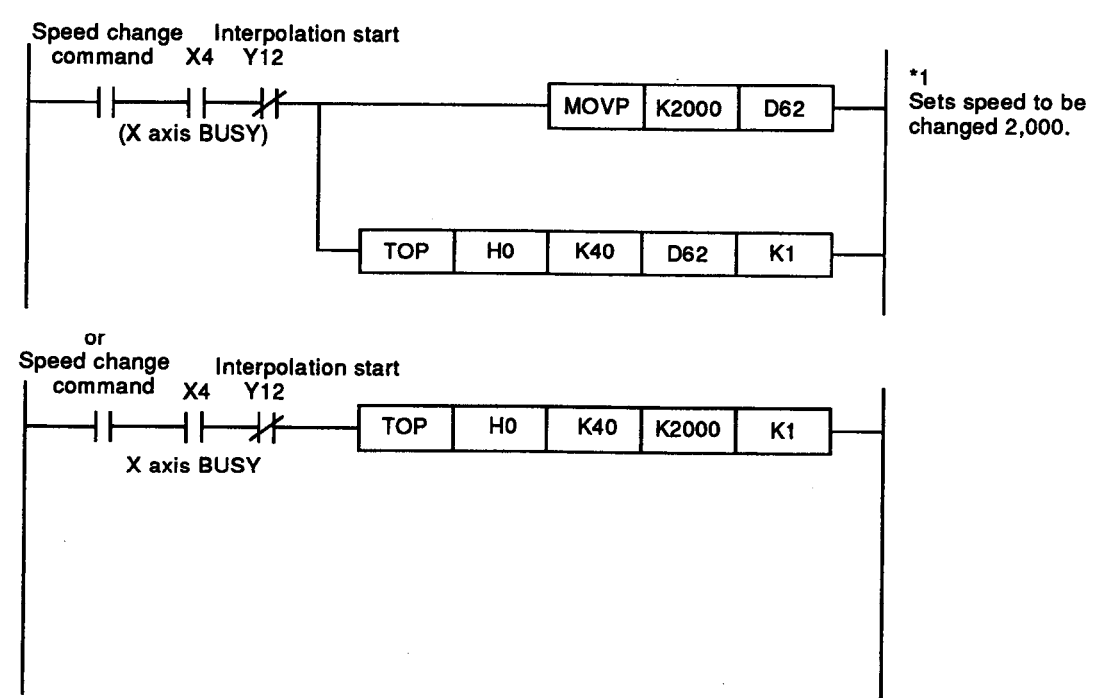

**POINT**

\*1 When the speed is changed to 2,000 in a program, it is internally processed as  $2,000 \times 10^1$ . Therefore, the actual speed becomes 20,000 mm/min.

(7) Error reset program example

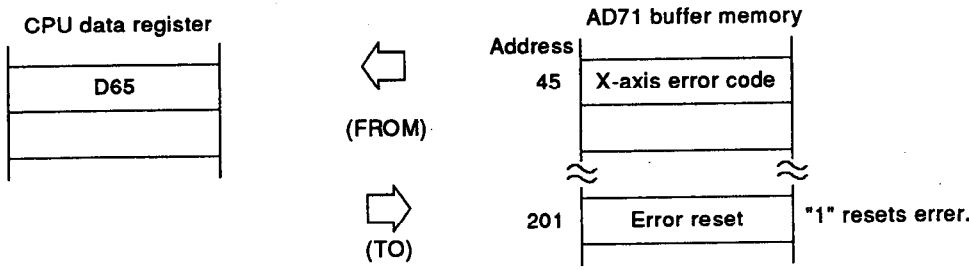
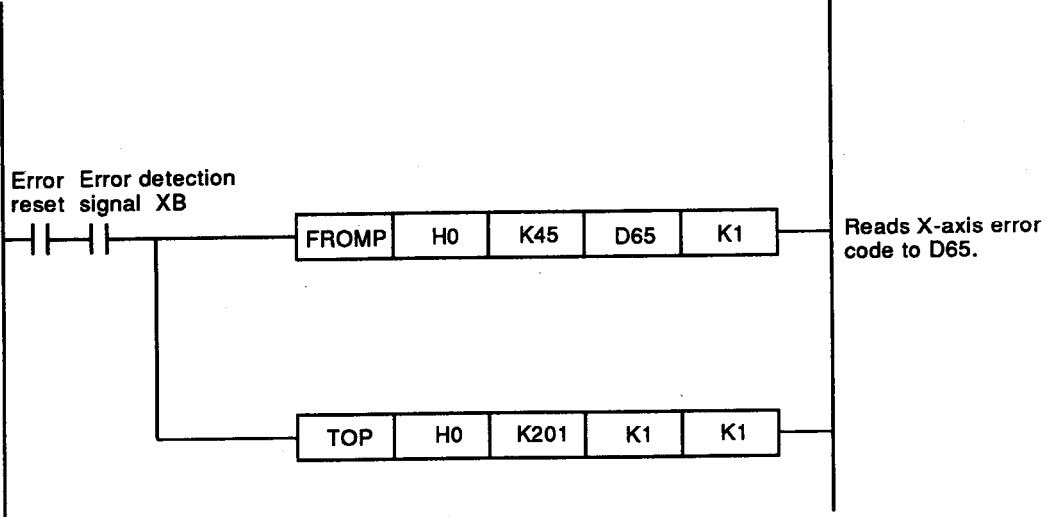
<b>[Example]</b>	To read a X axis error code and then reset it.
<b>[Notes]</b>	(1) The error detection (XB) signal should be used. (2) The buffer memory error reset (address 201) is used for both the X and Y axes. Writing a 1 to this address clears the error.
<b>[Data transfer]</b>	
<b>[Program]</b>	
<div style="border: 1px solid black; padding: 5px; display: inline-block; margin-bottom: 10px;"><b>REMARK</b></div> <p>Writing "1" to the buffer memory error reset address resets the error code and XB. The error reset address is then automatically changed to "0".</p>	

### 6.3.3 Positioning start program

There are two start programs (a) and (b) below.

- (a) **When setting data is written by using a peripheral device**  
The program is simple because it is not necessary to communicate setting data between a ACPU and AD71.  
This method is recommended when the positioning data is within 400 points and there are few setting data changes.
  
- (b) **When setting data is externally set**  
When there are a great many positioning data changes, communications between the ACPU and AD71 and a program for the writing/reading to/from the buffer memory are necessary.  
Many data registers and programs must be utilized and the operations takes a long time. Therefore, simplify operations without using unnecessary programs.

(1) Flow chart

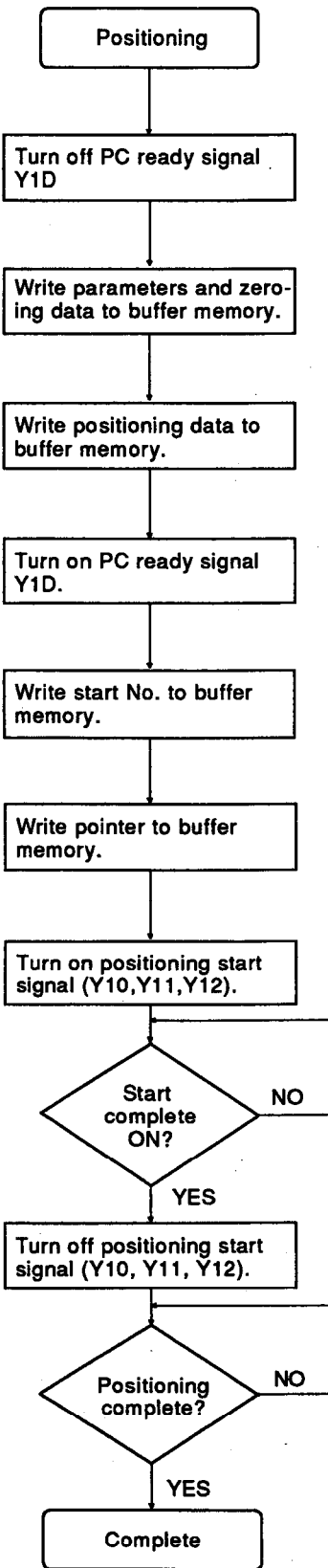

(2) Conditions Signal State Remarks

Table 6.1 Start Conditions

	Signal	State	Remarks
External signal	Drive unit READY	ON	
	Stop signal STOP	OFF	
Interface signal	AD71 ready (X1)	ON	*
	Relevant axis busy (X4, X5)	OFF	
	Relevant axis positioning commenced (X8, X9)	OFF	
	Relevant axis M code ON (XE, XF)	OFF	
	Relevant axis stop (Y15, Y16)	OFF	
	PC ready (Y1D)	ON	*
Other	Positioning data	Within setting range	If positioning speed is higher than the speed limit value, positioning is executed at the speed limit value.
	Start data number		
	Start axis		
	Pointer		
	Zero address		
	Monitor present value	$0 \leq \text{present value} \leq 16,252,928$	
After BREAK signal from the A6GPP or STOP signal from the AD71TU, neither axis should be busy.			

\* In the peripheral device test mode, X1 and Y1D may remain off.

(3) Timing

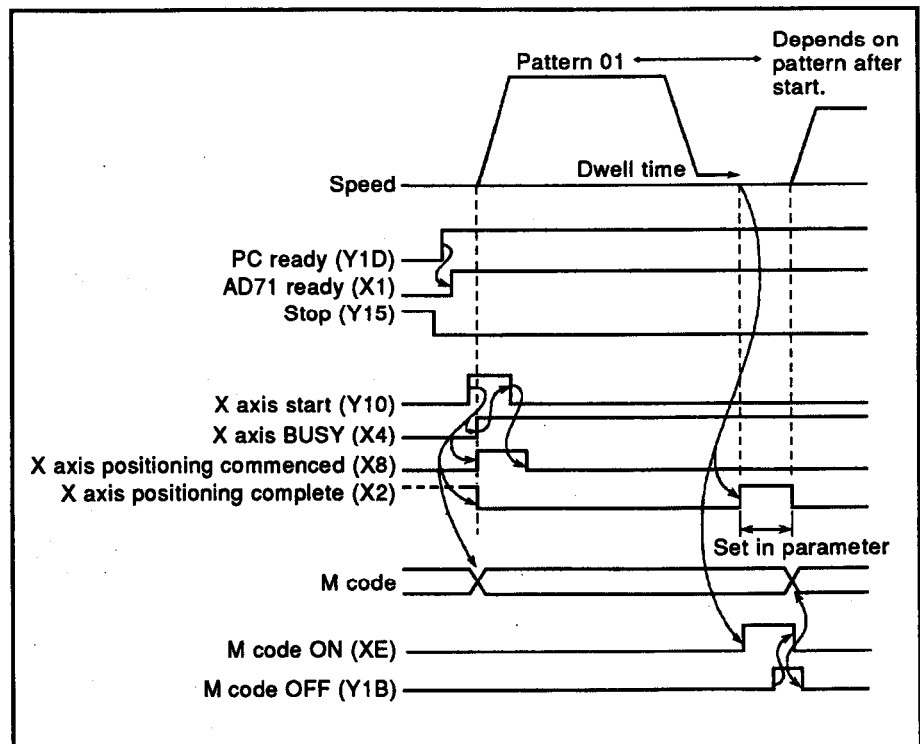

(4) Program

(a) Operating data already written from the peripheral device or AD71TU.

The following program assumes that parameters, zero return data, and positioning data have already been written to the AD71 buffer memory using the peripheral device or AD71TU. (Note that some parameters should be written from the sequence program.)

<b>[Example]</b>	To start at X axis data number 1.																																														
<b>[Notes]</b>	(1) For start conditions, see Table 6.1. Provide necessary interlock in accordance with its use. (2) Actual positioning operation depends on data No. 1 pattern setting. (3) For stop during positioning, refer to Section 6.3.11.																																														
<b>[Data transfer]</b>	<div style="display: flex; justify-content: space-around; align-items: center;"> <div style="text-align: center;"> <p>CPU data register</p> <p>To write start data No.</p> <table border="1" style="margin: auto;"> <tr><td style="width: 40px; height: 20px;">D2</td></tr> <tr><td style="width: 40px; height: 20px;">D3</td></tr> </table> </div> <div style="font-size: 2em; margin: 0 20px;">➔</div> <div style="text-align: center;"> <p>AD71 buffer memory</p> <p>Address</p> <table border="1" style="margin: auto;"> <tr><td style="width: 40px; height: 20px;">0</td></tr> <tr><td style="width: 40px; height: 20px;">7889</td></tr> </table> </div> </div>	D2	D3	0	7889																																										
D2																																															
D3																																															
0																																															
7889																																															
<b>[Program]</b>	<div style="border: 1px dashed black; padding: 10px; margin-bottom: 10px;"> <p>Creating necessary programs for AD71</p> <p>[ Program for AD71(S1/S7) or A1SD71-S7 : Refer to Fig. 6.2-2. ]</p> <p>[ Program for AD71S2 or A1SD71-S2 : Refer to Fig. 6.2-1. ]</p> </div> <div style="border: 1px solid black; padding: 10px;"> <table style="width: 100%; border-collapse: collapse;"> <tr> <td style="width: 15%; border-right: 1px solid black; padding: 5px;">X-axis start</td> <td style="width: 15%; border-right: 1px solid black; padding: 5px;">X1</td> <td style="width: 15%; border-right: 1px solid black; padding: 5px;">X4</td> <td style="width: 15%; border-right: 1px solid black; padding: 5px;">X8</td> <td style="width: 15%; border-right: 1px solid black; padding: 5px;">XB</td> <td style="width: 15%; border-right: 1px solid black; padding: 5px;">XE</td> <td style="width: 15%; padding: 5px;">Interlock</td> <td style="width: 15%; padding: 5px;">PLS M30</td> <td style="width: 15%;"></td> </tr> <tr> <td style="border-right: 1px solid black; padding: 5px;">M30</td> <td colspan="5" style="border-right: 1px solid black; padding: 5px;"></td> <td style="padding: 5px;">MOV K1 D2</td> <td style="padding: 5px;">Set the start data number (No. 1)</td> <td></td> </tr> <tr> <td style="border-right: 1px solid black; padding: 5px;"></td> <td colspan="5" style="border-right: 1px solid black; padding: 5px;"></td> <td style="padding: 5px;">T H0 K0 D2 K1</td> <td style="padding: 5px;">Write the data number to buffer memory address 0.</td> <td></td> </tr> <tr> <td style="border-right: 1px solid black; padding: 5px;"></td> <td colspan="5" style="border-right: 1px solid black; padding: 5px;"></td> <td style="padding: 5px;">SET Y10</td> <td style="padding: 5px;">X-axis start signal</td> <td></td> </tr> <tr> <td style="border-right: 1px solid black; padding: 5px;">Y10</td> <td style="border-right: 1px solid black; padding: 5px;">X8</td> <td colspan="5" style="border-right: 1px solid black; padding: 5px;"></td> <td style="padding: 5px;">RST Y10</td> <td style="padding: 5px;">Reset the X-axis start signal by using the X-axis start complete.</td> <td></td> </tr> </table> </div>	X-axis start	X1	X4	X8	XB	XE	Interlock	PLS M30		M30						MOV K1 D2	Set the start data number (No. 1)								T H0 K0 D2 K1	Write the data number to buffer memory address 0.								SET Y10	X-axis start signal		Y10	X8						RST Y10	Reset the X-axis start signal by using the X-axis start complete.	
X-axis start	X1	X4	X8	XB	XE	Interlock	PLS M30																																								
M30						MOV K1 D2	Set the start data number (No. 1)																																								
						T H0 K0 D2 K1	Write the data number to buffer memory address 0.																																								
						SET Y10	X-axis start signal																																								
Y10	X8						RST Y10	Reset the X-axis start signal by using the X-axis start complete.																																							

# 6. PROGRAMMING

(b) Setting data specified using sequence program

Assumes data is stored in registers as shown in Table 6.2.

[Notes]								
		(1) For start conditions, see Table 6.1.						
		Provide necessary interlock in accordance with its use.						
		(2) For stop during positioning, refer to Section 6.3.11.						
		(3) To write parameters and zero return data, turn off PC ready signal (Y1D).						
[Data transfer]								
		ACPU data register (Data already written)		AD71 buffer memory				
(X axis)								
1st point	start data No.	D0		0				
2nd point	start data No.	D1		1				
	start axis	D2		2				
3rd point	start data No.	D3		3				
	start axis	D4		4				
X axis pointer		D5		39				
(Y axis)								
1st point	start data No.	D10		300				
2nd point	start data No.	D11		301				
	start axis	D12		302				
3rd point	start data No.	D13		303				
	start axis	D14		304				
Y axis pointer		D15		339				
(X axis)								
Positioning information data		No.1 D20		3872				
		No.2 D21		3873				
		No.3 D22		3874				
		No.4 D23	→	3875				
		No.5 D24		3876				
		No.6 D25		3877				
		No.7 D26		3878				
		No.8 D27		3879				
		No.9 D28		3880				
		No.10 D29		3881				
(X axis)								
Positioning speed data		No.1 D30		4272				
		No.2 D31		4273				
		No.3 D32		4274				
		No.4 D33		4275				
		No.5 D34		4276				
		No.6 D35		4277				
		No.7 D36		4278				
		No.8 D37		4279				
		No.9 D38		4280				
		No.10 D39		4281				
						(X axis)		
						Dwell time data		
						No.1	D40	4672
						No.2	D41	4673
						No.3	D42	4674
						No.4	D43	4675
						No.5	D44	4676
						No.6	D45	4677
						No.7	D46	4678
						No.8	D47	4679
						No.9	D48	4680
						No.10	D49	4681
						(X axis)		
						Positioning address data		
						No.1	D50	5072
						No.2	D51	5073
							D52	5074
						No.3	D53	5075
							D54	5076
						No.4	D55	5077
							D56	5078
						No.5	D57	5079
							D58	5080
						No.6	D59	5081
							D60	5082
						No.7	D61	5083
							D62	5084
						No.8	D63	5085
							D64	5086
						No.9	D65	5087
							D66	5088
						No.10	D67	5089
							D68	5090
							D69	5091
						(Y axis positioning data omitted)		

(X axis parameters)		
Parameter Information	D120	7872
Travel per pulse	D121	7873
Speed limit value	D122	7874
Jog speed limit value	D123	7875
Acceleration and deceleration times	D124	7876
Backlash compensation	D125	7877
Upper stroke limit	D126	7878
	D127	7879
Lower stroke limit	D128	7880
	D129	7881
Error compensation	D130	7882
	D131	7883
*1 Travel distance per manual pulse pulse	D132	7884
	D133	7885
Starting bias speed	D134	7886
Positioning complete signal output duration	D135	7887
Deceleration time for emergency stop	D136	7888
Positioning mode	D137	7889
(Y axis parameters)		
Parameter information	D140	7892
Travel per pulse	D141	7893
Speed limit value	D142	7894
Jog speed limit value	D143	7895
Acceleration and deceleration times	D144	7896
Backlash compensation	D145	7897
Upper stroke limit	D146	7898
	D147	7899
Lower stroke limit	D148	7900
	D149	7901
Error compensation	D150	7902
	D151	7903
*1 Travel distance per manual pulse pulse	D152	7904
	D153	7905
Starting bias speed	D154	7906
Positioning complete signal output duration	D155	7907
*2 Deceleration time for emergency stop	D156	7908
(X axis zero return data)		
Zero address	D160	7912
	D161	7913
Zero return speed	D162	7914
Zero return creep speed	D163	7915
Zero return dwell time	D164	7916
Torque limit	D165	7917
Zero return information	D166	7918
(Y axis zero return data)		
Zero address	D170	7922
	D171	7923
Zero return speed	D172	7924
Zero return creep speed	D173	7925
Zero return dwell time	D174	7926
Torque limit	D175	7927
Zero return information	D176	7928

Table 6.2 Data Register Contents

Item		Data Register	
X axis start data number (3 points)		D0 to 4	
X axis pointer (2)		D5	
Y axis start data number (3 points)		D10 to 14	
Y axis pointer (2)		D15	
Positioning data	X axis	Positioning information (No. 1 to 10)	D20 to 29
		Positioning speed (No. 1 to 10)	D30 to 39
		Dwell time (No. 1 to 10)	D40 to 49
		Positioning address (No. 1 to 10)	D50 to 69
	Y axis	Positioning information (No. 1 to 10)	D70 to 79
		Positioning speed (No. 1 to 10)	D80 to 89
		Dwell time (No. 1 to 10)	D90 to 99
		Positioning address (No. 1 to 10)	D100 to 119
X axis parameters		D120 to 137	
Y axis parameters		D140 to 156	
X axis zero return data		D160 to 166	
Y axis zero return data		D170 to 176	

**REMARKS**

- 1) Set the data register number to any desired value.
- 2) The buffer memory address is fixed.
- \*1: Set a value within the setting range even if an AD71S2 or A1SD71-S2 is used.
- \*2: Set a value only when an AD71S2 or A1SD71-S2 is used.

[Example 1] X axis start  
 (On the assumption that, of the above data, only X-axis data is set. Y-axis data is not required.)

Creating necessary programs for AD71

- [ Program for AD71(S1/S7) or A1SD71-S7 : Refer to Fig. 6.2-2. ]
- [ Program for AD71S2 or A1SD71-S2 : Refer to Fig. 6.2-1. ]

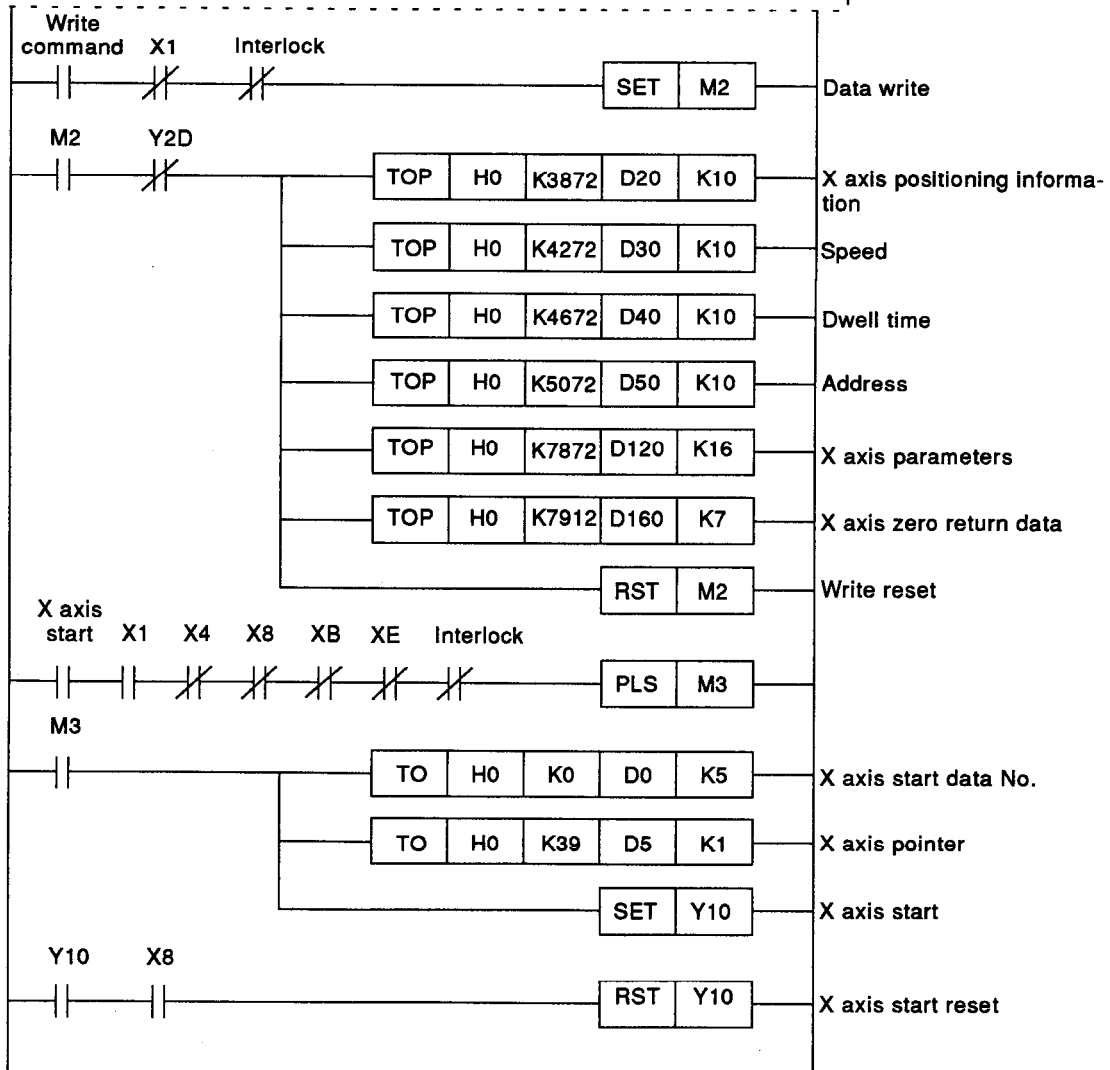

Timing is same as on page 6-16.



[Example 2] Start programs  
 Program to start the X and Y axes, interpolation starts, and zero return are possible.

Creating necessary programs for AD71  
 [ Program for AD71(S1/S7) or A1SD71-S7 : Refer to Fig. 6.2-2. ]  
 [ Program for AD71S2 or A1SD71-S2 : Refer to Fig. 6.2-1. ]

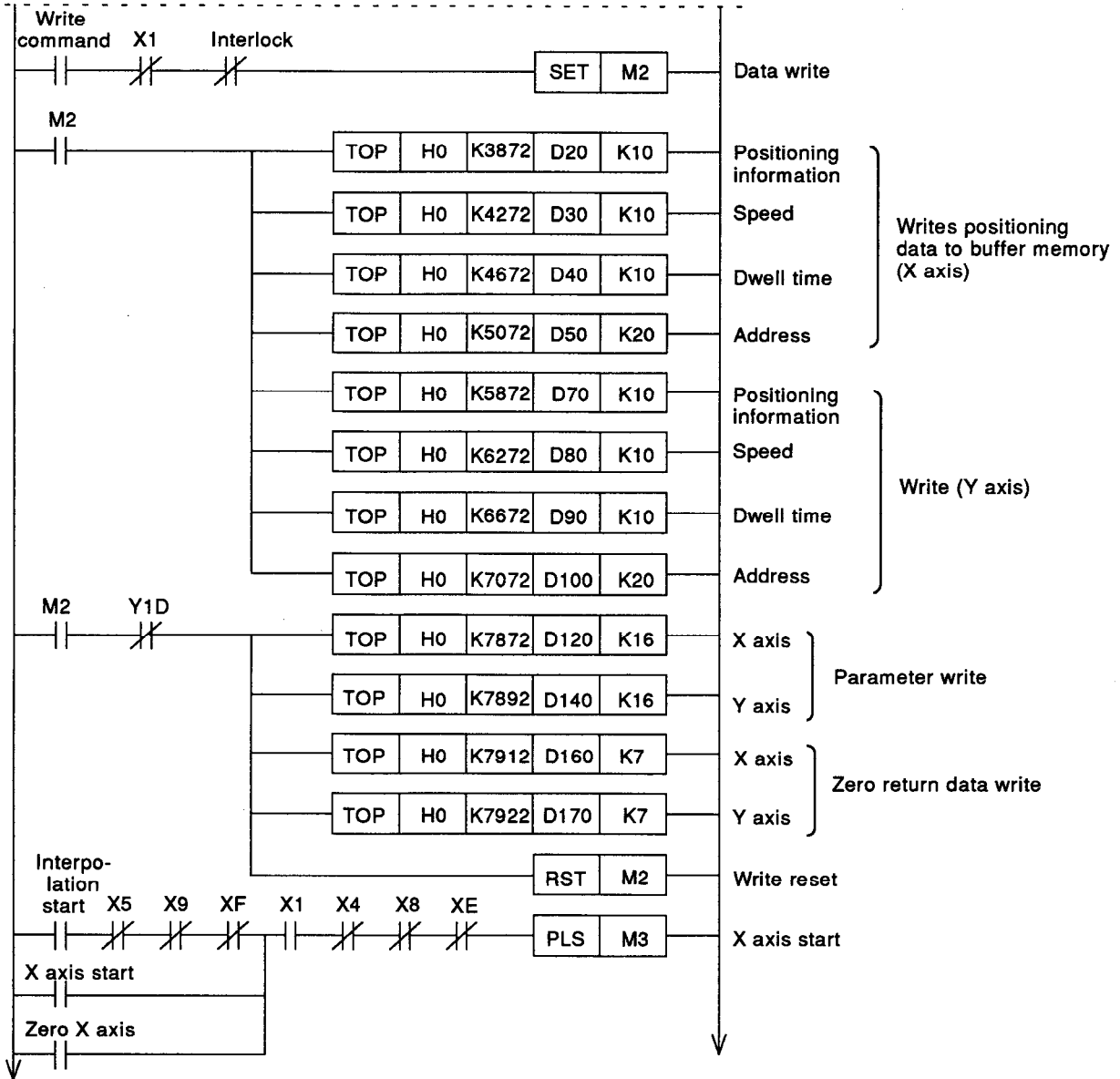

(To be continued)

(Continued from preceding page)

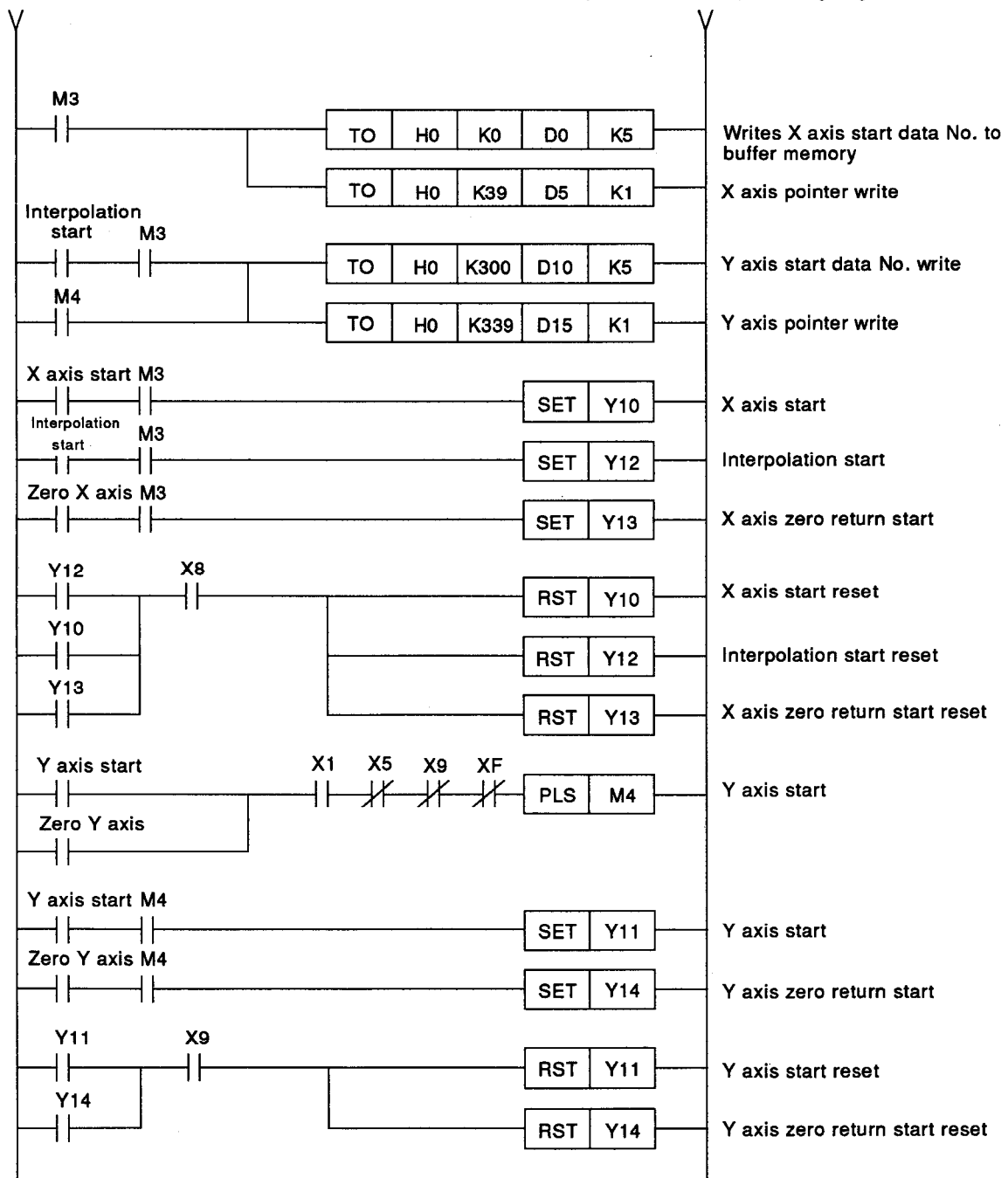

**Note :** For time schedule, refer to Fig. 3.50

6.3.4 Speed/positioning control switching program (for AD71S2 or A1SD71-S2)

(1) Flow chart

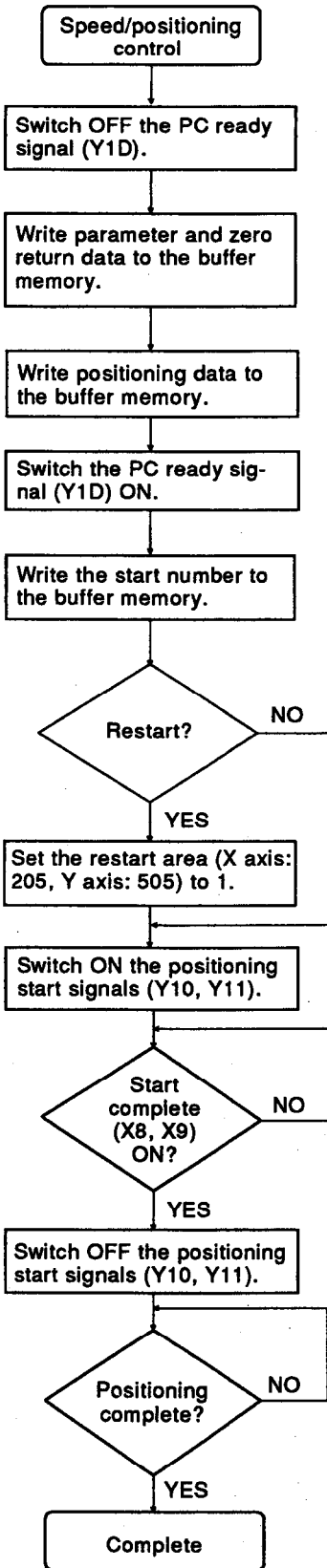

(2) Conditions

Table 6.3 Start Conditions

	Signal	State at Start	State at Restart	Remarks
External signals	Drive unit READY	ON	ON	
	Stop signal STOP	OFF	OFF	
Interface signals	AD71 ready signal (X1)	ON	ON	*
	Relative axis BUSY signals (X4, X5)	OFF	OFF	
	Relative axis positioning commenced signals (X8, X9)	OFF	OFF	*
	Relative axis M code ON signals (XE, XF)	OFF	OFF	*
	Relative axis stop signals (Y15, Y16)	OFF	OFF	
	PC ready signal (Y1D)	ON	ON	*
Others	Positioning data	Within the setting range.	Within the setting range. The start data number should be the same as the execution data number.	If the positioning speed is specified higher than the speed limit value, operations are performed at the speed limit value.
	Start data number			
Zero address				
	Timing		Stop during operations after positioning has already been started. This should be the initial start.	

Neither axis should be busy after a BREAK signal has been received from a peripheral device or after a STOP signal has been received from the AD71TU.

\* In the peripheral device test mode, the signals are not checked.

(3) Timing

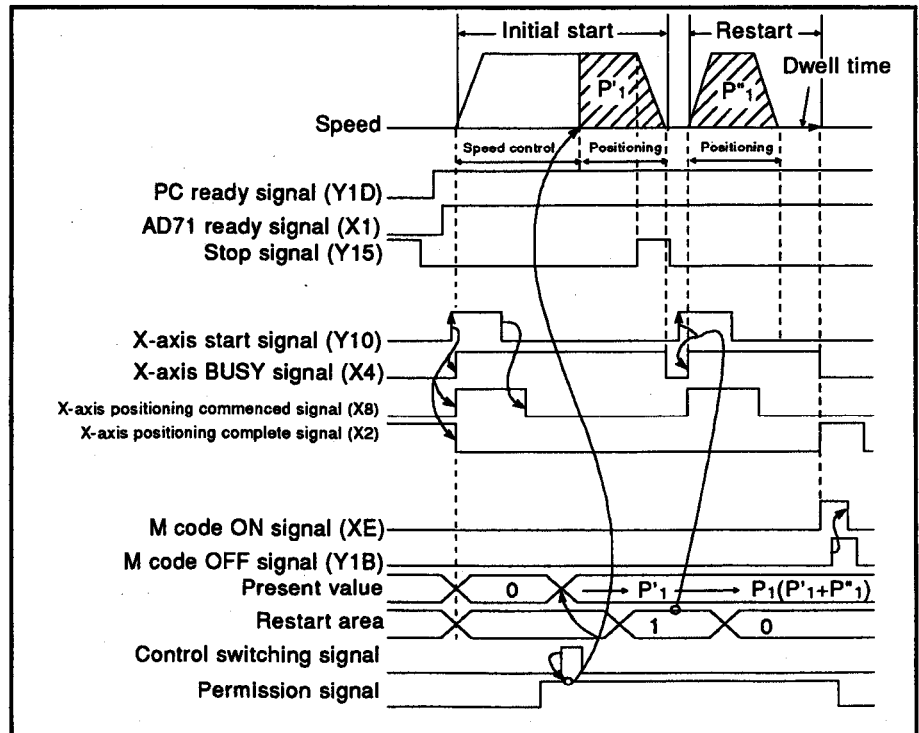

(4) Program

(a) When setting data has been already written using a peripheral device.

The following shows the program when parameter, zero return data, and positioning data have been already written to the AD71 buffer memory using a peripheral device.

(However some data should be written to the parameter using a sequence program.)

[Example]	To start, stop, and restart X-axis data number 1.									
[Notes]	<p>(1) Start conditions are shown in Table 6.3. Provide necessary interlock in accordance with its use.</p> <p>(2) Speed/positioning control operation after start follow the pattern specification of data number 1.</p>									
[Data transfer]	<div style="display: flex; justify-content: space-around; align-items: center;"> <div style="text-align: center;"> <p>ACPU data register</p> <table border="1" style="border-collapse: collapse; width: 80px;"> <tr><td style="height: 20px;"> </td></tr> <tr><td style="text-align: center;">D2</td></tr> <tr><td style="text-align: center;">D3</td></tr> <tr><td style="text-align: center;">D4</td></tr> <tr><td style="height: 20px;"> </td></tr> </table> </div> <div style="font-size: 2em; margin: 0 20px;">➔</div> <div style="text-align: center;"> <p>AD71 buffer memory</p> <table border="1" style="border-collapse: collapse; width: 80px;"> <tr><td style="text-align: center;">0</td></tr> <tr><td style="text-align: center;">205</td></tr> <tr><td style="text-align: center;">7889</td></tr> <tr><td style="height: 20px;"> </td></tr> </table> </div> </div> <p style="margin-top: 20px;">To write the start data number</p>		D2	D3	D4		0	205	7889	
D2										
D3										
D4										
0										
205										
7889										

[Program] To start and restart data number 1

Necessary program for AD71S2 or A1SD71-S2 (Refer to Fig. 6.2-1.)

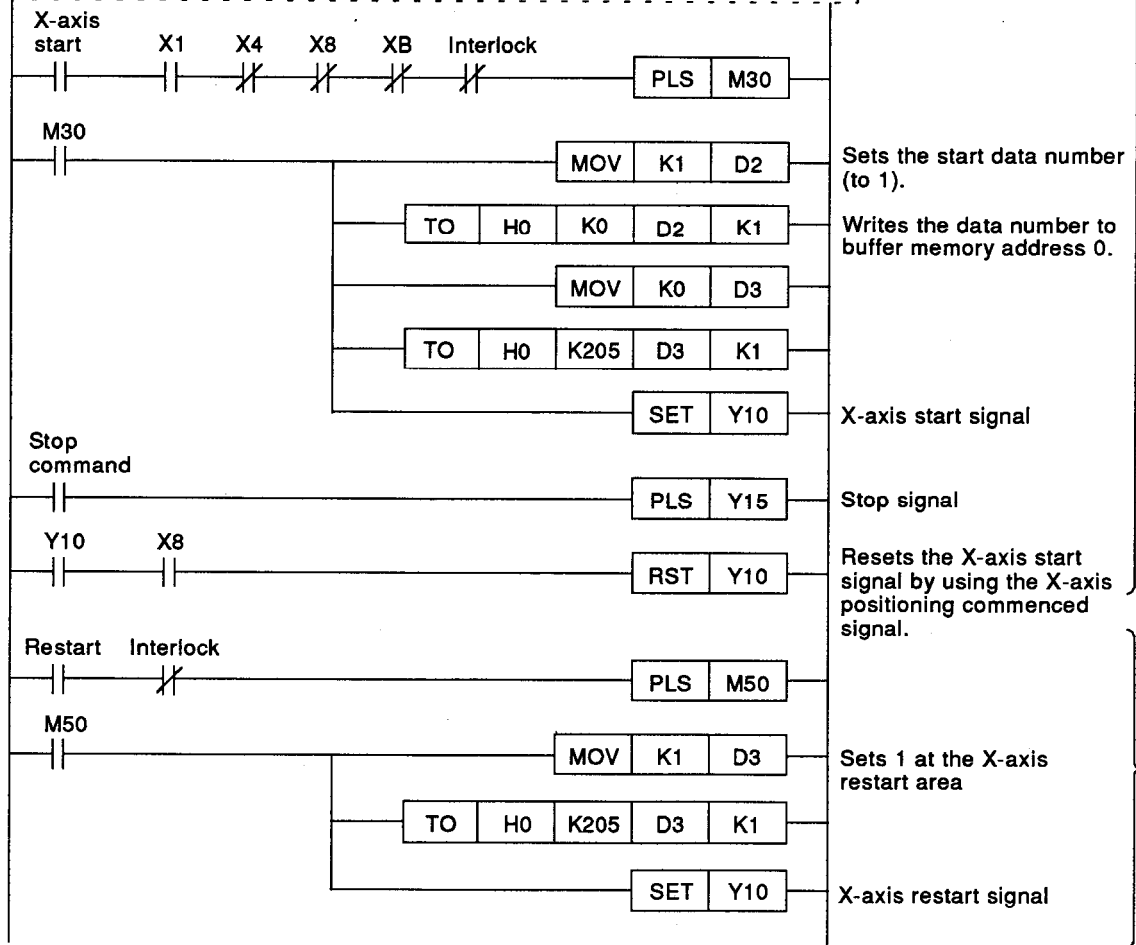

Start

Restart

6.3.5 Speed control program (for AD71S2 or A1SD71-S2)

(1) Flow chart

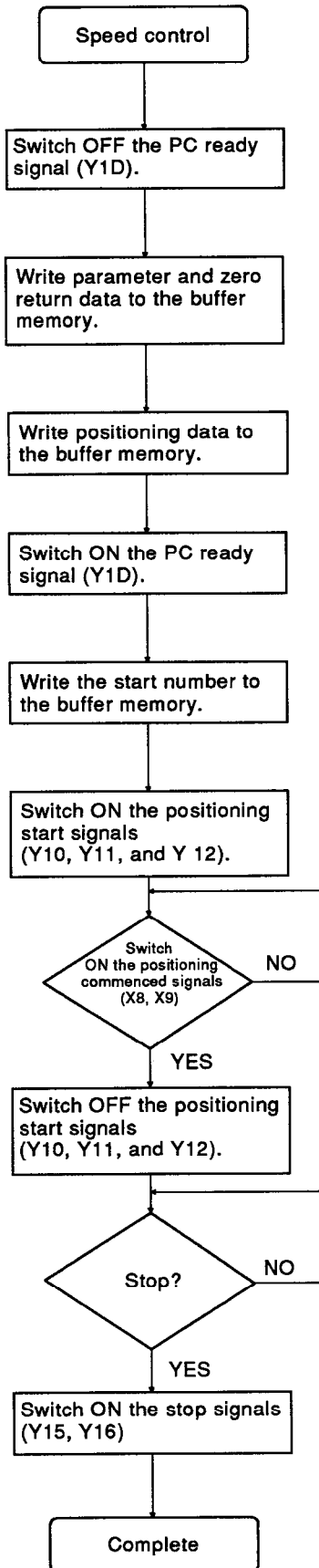

(2) Conditions

Table 6.4 Start Conditions

	Signal	State	Remarks
External signals	Drive unit READY	ON	
	Stop signal STOP	OFF	
Interface signals	AD71 ready signal (X1)	ON	*
	Relative axis BUSY signals (X4, X5)	OFF	
	Relative axis positioning commenced signals (X8, X9)	OFF	*
	Relative axis M code ON signals (XE, XF)	OFF	*
	Relative axis stop signals (Y15, Y16)	OFF	
	PC ready signal (Y1D)	ON	*
Others	Positioning data	Within the setting range.	If the positioning speed is specified higher than the speed limit value, operations are performed at the speed limit value.
	Start data number		
Neither axis should be BUSY after a BREAK signal has been received from the A6GPP or after a STOP signal has been received from the AD71TU.			

\* In the peripheral device test mode, the signals are not checked.

(3) Timing

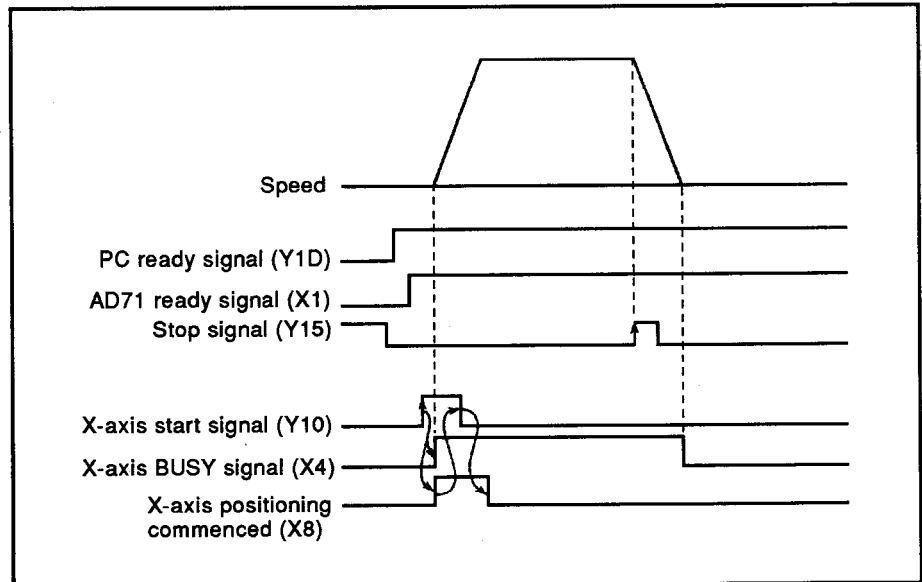

(4) Program

- (a) The following shows the program when parameter, zero return data, and positioning data have been already written to the AD71 buffer memory using a peripheral device.  
(However some data should be written to the parameter using a sequence program.)

<b>[Example]</b>	To start X-axis data number 1.					
<b>[Notes]</b>	(1) Start conditions are shown in Table 6.4. Provide necessary interlock in accordance with its use. (2) Speed/positioning control operation after start follow the pattern specification of data number 1.					
<b>[Data transfer]</b>	<div style="display: flex; justify-content: space-around; align-items: center;"> <div style="text-align: center;"> <p>CPU data register</p> <table border="1" style="margin: auto;"> <tr><td>D2</td></tr> <tr><td>D3</td></tr> </table> </div> <div style="font-size: 2em;">➔</div> <div style="text-align: center;"> <p>AD71 buffer memory</p> <table border="1" style="margin: auto;"> <tr><td>Address</td></tr> <tr><td>0</td></tr> <tr><td>7889</td></tr> </table> </div> </div>	D2	D3	Address	0	7889
D2						
D3						
Address						
0						
7889						
<b>[Program]</b>	<div style="border: 1px dashed black; padding: 10px; margin-bottom: 10px;"> <p>Necessary program for AD71S2 or A1SD71-S2 (Refer to Fig. 6.2-1.)</p> </div> <div style="margin-top: 10px;"> <table border="0" style="width: 100%;"> <tr> <td style="width: 50%; vertical-align: top;"> <p>X-axis start</p> <p>M30</p> <p>Stop command</p> <p>Y10</p> <p>X8</p> </td> <td style="width: 50%; vertical-align: top;"> <p>PLS M30</p> <p>MOV K1 D2</p> <p>T0 H0 K0 D2 K1</p> <p>SET Y10</p> <p>PLS Y15</p> <p>RST Y10</p> </td> </tr> <tr> <td></td> <td style="vertical-align: top;"> <p>Sets the start data number (to 1).</p> <p>Writes the data number to buffer memory address 0.</p> <p>X-axis start signal</p> <p>Stop signal</p> <p>Resets the X-axis start signal using the X-axis positioning commenced signal.</p> </td> </tr> </table> </div>	<p>X-axis start</p> <p>M30</p> <p>Stop command</p> <p>Y10</p> <p>X8</p>	<p>PLS M30</p> <p>MOV K1 D2</p> <p>T0 H0 K0 D2 K1</p> <p>SET Y10</p> <p>PLS Y15</p> <p>RST Y10</p>		<p>Sets the start data number (to 1).</p> <p>Writes the data number to buffer memory address 0.</p> <p>X-axis start signal</p> <p>Stop signal</p> <p>Resets the X-axis start signal using the X-axis positioning commenced signal.</p>	
<p>X-axis start</p> <p>M30</p> <p>Stop command</p> <p>Y10</p> <p>X8</p>	<p>PLS M30</p> <p>MOV K1 D2</p> <p>T0 H0 K0 D2 K1</p> <p>SET Y10</p> <p>PLS Y15</p> <p>RST Y10</p>					
	<p>Sets the start data number (to 1).</p> <p>Writes the data number to buffer memory address 0.</p> <p>X-axis start signal</p> <p>Stop signal</p> <p>Resets the X-axis start signal using the X-axis positioning commenced signal.</p>					

# 6. PROGRAMMING

## 6.3.6 Jog operation program

(1) Flow chart

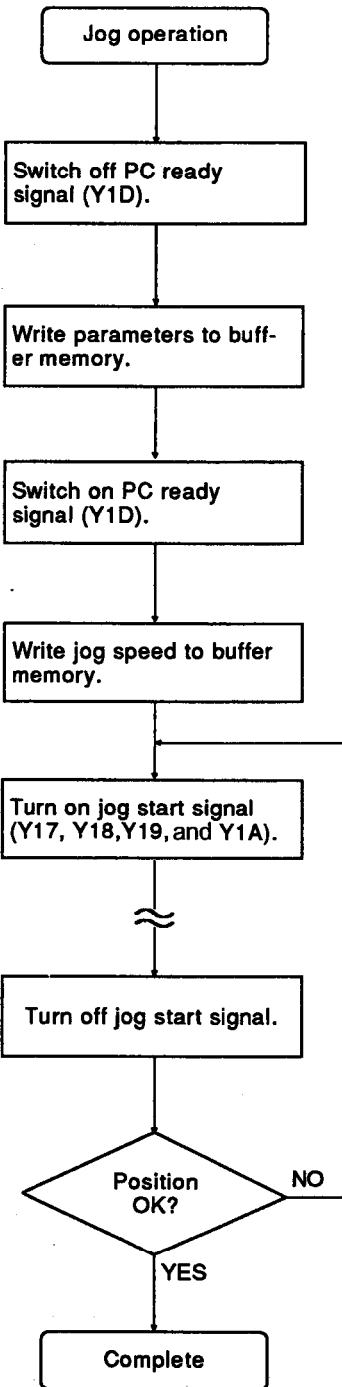

(2) Conditions

Table 6.5 Jog Operation Start Conditions

	Signal	State	Remarks
External signal	Drive unit READY	ON	
	Stop signal STOP	OFF	
Interface signal	AD71 ready (X1)	ON	*
	Relevant axis busy (X4, X5)	OFF	
	Relevant axis positioning commenced (X8, X9)	OFF	
	Relevant axis M code ON (XE, XF)	OFF	
	Relevant axis stop (Y15, Y16)	OFF	
	PC ready (Y1D)	ON	*
Others	Jog speed	Starting bias speed or higher	If jog speed specified is higher than the jog speed limit value, operation is performed at the jog speed limit value.
	Parameter	Must be within the permissible setting range.	
	Neither axis should be BUSY after a BREAK signal has been received from the A6GPP and both axes have stopped.		
	Neither axis should be BUSY after a STOP signal has been received from the AD71TU and both axes have stopped.		

\* In the peripheral device test mode, X1 and Y1D may remain off.

(3) Timing

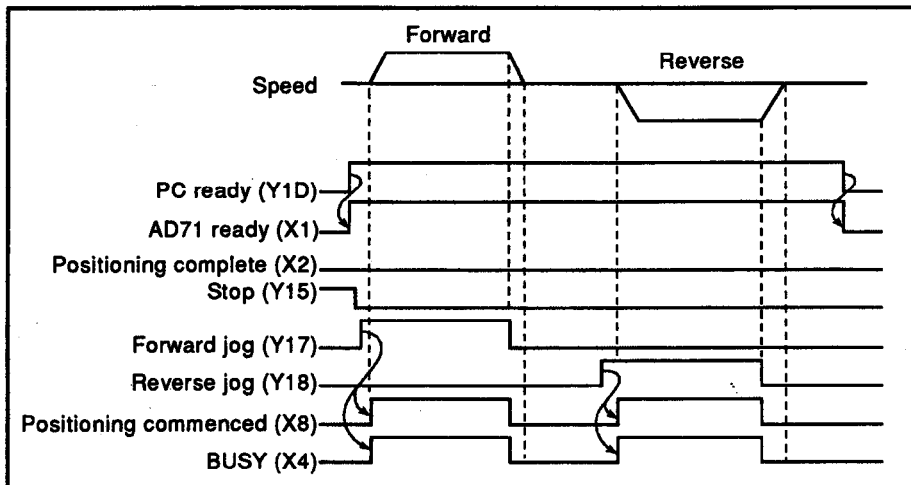

### POINTS

- (1) During jog operation the upper and lower stroke limits are ignored.
- (2) When backlash compensation has been specified, the minimum movement allowed will be the backlash specified.



(4) Program

The drive is enabled for as long as the jog switch is pressed.

[Example]	X axis jog at speed 2,000 (20,000 mm/min)						
[Notes]	Start conditions are shown in Table 6.5. The jog speed must be written to the buffer memory.						
[Data transfer]	<div style="display: flex; align-items: center; justify-content: space-around;"> <div style="text-align: center;"> <p>X axis jog operation speed 2,000</p> </div> <div style="font-size: 2em;">➔</div> <div style="text-align: center;"> <p>AD71 buffer memory</p> <table border="1" style="margin-left: auto; margin-right: auto;"> <tr> <td style="padding: 2px;">Address</td> <td style="padding: 2px;">44</td> </tr> <tr> <td style="padding: 2px;"> </td> <td style="padding: 2px;"> </td> </tr> <tr> <td style="padding: 2px;"> </td> <td style="padding: 2px;"> </td> </tr> </table> </div> </div>	Address	44				
Address	44						

[Program]

Creating necessary programs for AD71  
 [ Program for AD71(S1/S7) or A1SD71-S7 : Refer to Fig. 6.2-2. ]  
 [ Program for AD71S2 or A1SD71-S2 : Refer to Fig. 6.2-1. ]

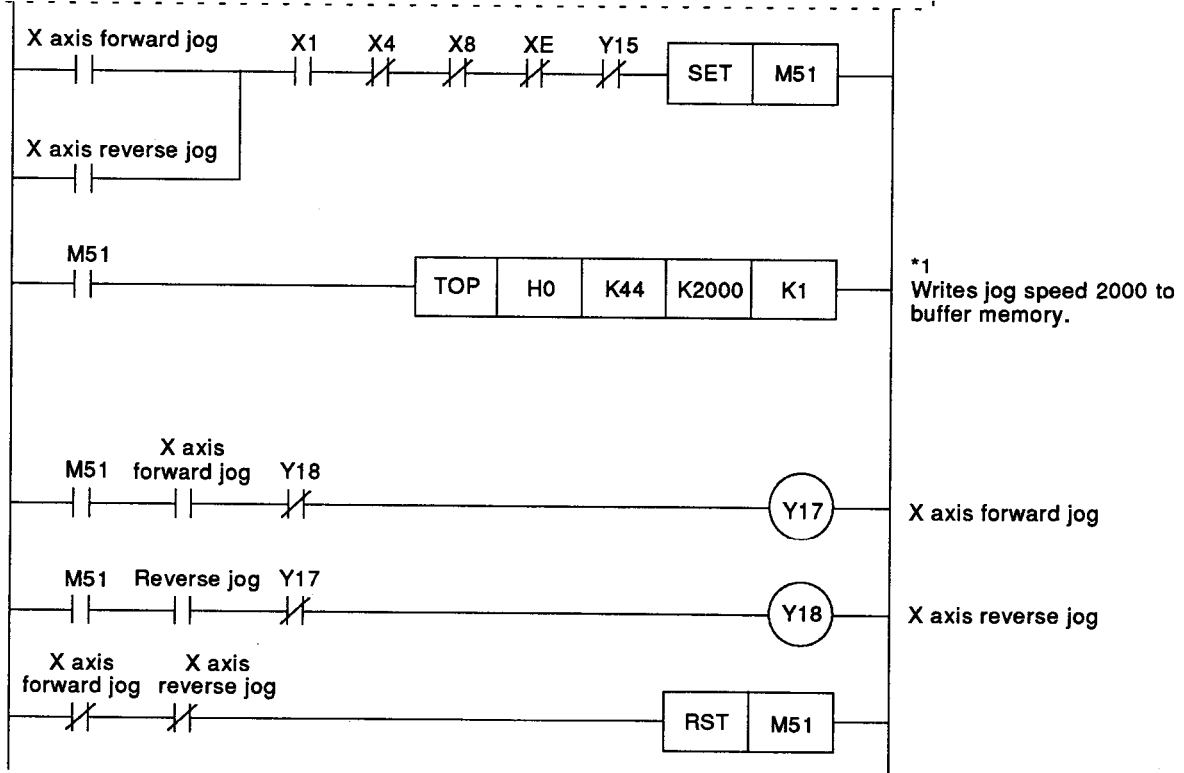

**REMARKS**

1. If the JOG start signal is turned on again after being turned off during deceleration, the speed will decrease to 0, then JOG operation will automatically resume.

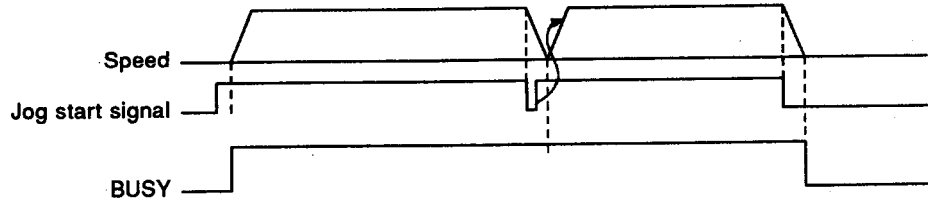
**Fig. 6.7 Jog Repetition**

2. Interpolation is not enabled during jog operation.
3. The AD71 defaults to forward jog if both forward and reverse jog commands are given simultaneously.

**POINT**

\*1 When the speed is changed to 2,000 in a program, it is internally processed as  $2,000 \times 10^1$ . Therefore, the actual speed becomes 20,000 mm/min.

6.3.7 Manual pulse operation program (for AD71(S1/S7) or A1SD71-S7)

The following principle underlies positioning by manual pulse operation:

- (1) When the manual pulse is operated, the pulse is transmitted to the AD71.
- (2) The AD71 converts the received pulse into an output pulse.

The AD71 requires several tens of milliseconds to perform internal processing, such as output pulse conversion.

Conversion expression

$$\text{Number of AD71 output pulses} = \frac{R \times Q}{P} \dots\dots (\text{Expression 1})$$

- P: "Travel distance per pulse" in the parameters (setting unnecessary when the set unit is "PLS")
- Q: "Travel distance per manual puls" in the parameters
- R: Number of input manual pulse pulses

- (3) The AD71 transmits output pulses, calculated in accordance with Expression 1, to the drive unit. The AD71 transmits output pulses as shown below:

- (a) In response to each input pulse from the manual pulse to the AD71, the AD71 transmits output pulses to the drive unit.

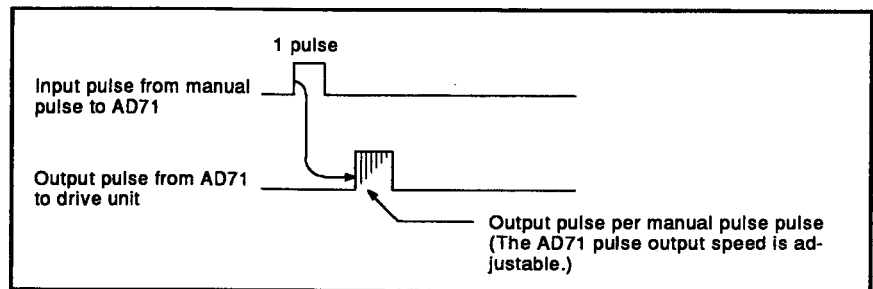

- (b) The AD71 requires the time calculated from the following expression to complete pulse output in response to each manual pulse.

(The pulse output speed of the AD71S7 or A1SD71-S7 depends on the manual pulse output speed setting in the buffer memory (address 202 or 502). If the manual pulse output speed is too fast, the drive unit may not respond to it. In such a case, set a lower pulse output speed.)

$$\text{AD71 pulse output time} = \frac{(\text{AD71 internal processing time}) + (\text{Pulse output time}) [\text{ms}]}{1} \dots\dots (\text{Expression 2})$$

- 1) AD71 internal processing time: Several tens of milliseconds
- 2) Pulse output time:

$$\frac{(\text{Travel distance per manual pulse}) \times (\text{Number of pulses the AD71 counts})}{(\text{AD71 pulse output speed})^*} [\text{ms}] \dots\dots (\text{Expression 3})$$

\* In the case of the AD71(S1), the pulse output speed is fixed at 20,000 pulse/s.  
As for the AD71S7 and the A1SD71-S7, the pulse output speed is adjustable within the range of 10 pulse/s to 20,000 pulse/s (in 10 pulse/s units).

As soon as the AD 71 completes pulse output, it receives the next input pulse from the manual pulse, and accordingly transmits output pulses to the drive unit within the time calculated in accordance with Expression 2.

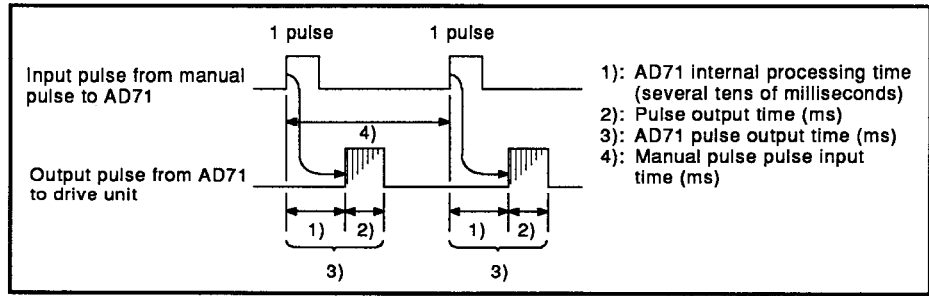

Consequently, the AD71 transmits output pulses intermittently even if it receives continuous pulse input.

If the manual pulse input time (ms) is shorter than the value obtained in accordance with Expression 2, output pulses remain in the AD71. These pulses will be transmitted after the AD71 completes each internal processing (several tens of milliseconds).

- (4) While the AD71 is transmitting pulses to the drive unit, the BUSY signal of the relevant axis is on.

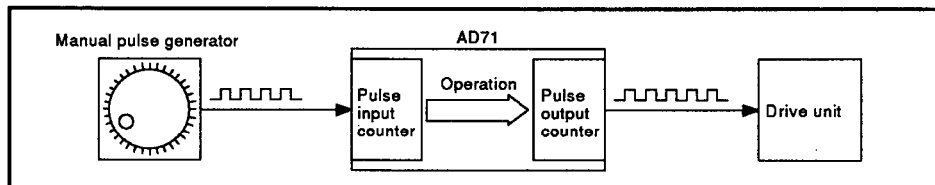

### POINTS

- (1) After manual pulse operation is completed, set "0" in the manual pulse enable area. If the manual pulse is operated with the setting unchanged from "0" (enabled), incorrect positioning may be performed.
- (2) Input pulses from the manual pulse generator are counted only when the following conditions are met:
  - The manual pulse enable area in the buffer memory is set to "1".
  - The relevant axis is not BUSY, or it is BUSY in the manual pulse mode.
- (3) About 2.2 seconds after the manual pulse enable area is set to "0" or the PC ready signal (Y1D) is turned off, the pulse input and pulse output counters are cleared. The pulse counters are cleared as soon as the stop signals (Y15 and Y16) are turned on.
- (4) The system does not start travelling in the direction of backlash if the number of output pulses is smaller than the backlash setting.
- (5) When the manual pulse does not start running due to an error, the pulse input counter will not be cleared. If the manual pulse continues transmitting input pulses to the AD71, the pulse input counter will cause an overflow, and will not retain the correct number of input pulses. After an error occurs, stop manual pulse operation, and write "0" to the manual pulse enable area to clear the pulse input counter. Then, rewrite "1" to the area, and start manual pulse operation.
- (6) The pulse output counter retains up to 16,777,215 pulses. If the number of output pulses exceeds this value, an overflow will occur, and the excess pulses will not be counted. A pulse output counter overflow can be prevented by setting a limit on the number of input pulses or increasing the manual pulse output speed (when an AD71S7 or A1SD71-S7 is used.)

(1) Flow chart

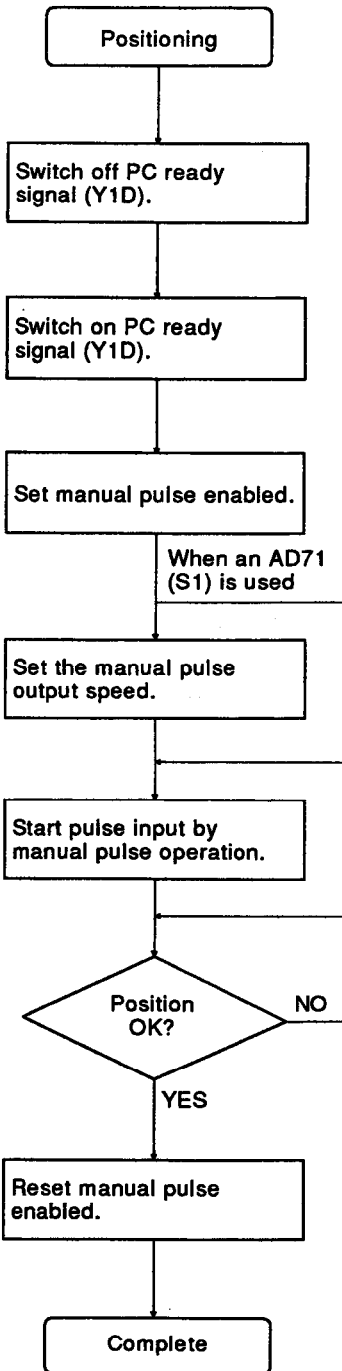

(2) Conditions

Table 6.6 Manual Pulse Operation Start Conditions

	Signal	State	Remarks
External signal	Drive unit READY	ON	
	Stop signal STOP	OFF	
Interface signal	AD71 ready (X1)	ON	*
	Relevant axis busy (X4, X5)	OFF	On during manual pulse generation.
	Relevant axis positioning commenced (X8, X9)	OFF	
	Relevant axis M code ON (XE, XF)	OFF	
	Relevant axis stop (Y15, Y16)	OFF	
	PC ready (Y1D)	ON	*
Others	Buffer memory "manual pulse enable" [ X axis: address 47 Y axis: address 347 ]	Bit = 1	When bit = 0, pulse input by manual pulse operation will be ignored. It will not cause any error.
	Parameter	Within the setting range.	In the case of the AD71S7 and A1SD71-S7, the pulse output speed is adjustable.
	Buffer memory manual pulse output speed (202, 502)		
The relevant axis should not be BUSY after a BREAK signal has been transmitted from a peripheral device using the A6GPP function, or after a STOP signal has been transmitted from the AD71TU.			

\* In the peripheral device test mode, the signals may remain off.

(3) Timing

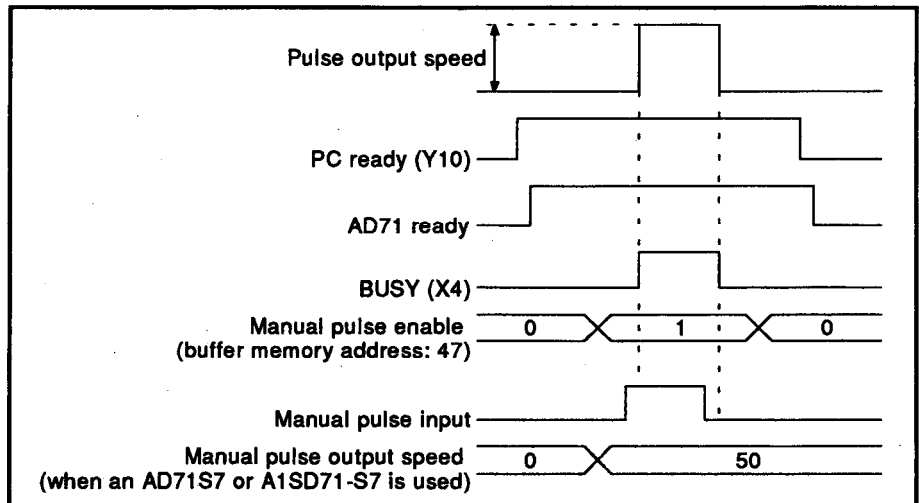

**IMPORTANT**

An error (code 73) will occur if manual pulse operation starts with manual pulse enabled set in the positioning, zero return or JOG operation mode while the relevant axis is BUSY. Write 0 (disabled) to the manual pulse enable area for modes other than the manual pulse mode.

(4) Program

<b>[Example]</b>	X axis manual pulse operation								
<b>[Notes]</b>	The start conditions are shown in Table 6.6.								
<b>[Data transfer]</b>	<div style="display: flex; align-items: center; justify-content: space-around;"> <div style="text-align: center;"> <p>"1"</p> <p>"0"</p> </div> <div style="font-size: 2em;">➔</div> <div style="text-align: center;"> <p>Address</p> <table border="1" style="border-collapse: collapse;"> <tr> <td style="width: 20px; height: 20px;"></td> <td style="width: 20px; height: 20px; text-align: center;">47</td> <td style="width: 20px; height: 20px;"></td> <td style="width: 20px; height: 20px;"></td> </tr> <tr> <td style="width: 20px; height: 20px;"></td> <td style="width: 20px; height: 20px;"></td> <td style="width: 20px; height: 20px;"></td> <td style="width: 20px; height: 20px;"></td> </tr> </table> </div> <div style="text-align: right;"> <p>*1*: Manual pulse operation enabled *0*: Disabled</p> </div> </div>		47						
	47								
<b>[Program]</b>	<div style="border: 1px dashed black; padding: 10px; margin-bottom: 10px;"> <p>Necessary program for AD71(S1/S7) or A1SD71-S7 (Refer to Fig. 6.2-2.)</p> </div> <div style="display: flex; align-items: flex-start;"> <div style="flex: 1;"> </div> <div style="flex: 1; padding-left: 10px;"> <p>X axis Enables manual pulse operation.</p> <p>X axis The manual pulse output speed is set at 500 pulse/s.</p> <p>X axis Disables manual pulse operation.</p> </div> <div style="flex: 0.5; padding-left: 10px; border-left: 1px dashed black; border-right: 1px dashed black;"> <p>Setting required only for AD71S7 or A1SD71-S7.</p> </div> </div>								

### 6.3.8 Positioning address teaching program

Positioning addresses can be written using devices.

(1) Using the jog operation

Addresses set by using the jog operation are written to the target data number of the AD71 buffer memory.

(2) Method by manual pulse operation (when an AD71(S1/S7) or A1SD71-S7 is used)

This method executes fine positioning by JOG operation, and requires an additional pulse.

The manual pulse determines the address, and the system writes the address to the reserved data area number in the AD71 buffer memory.

(3) Method using both JOG operation and manual pulse operation JOG operation is used for approximate positioning, and a manual pulse for fine positioning of the last address.

# 6. PROGRAMMING

[1] Jog to position and teach

(1) Flow chart

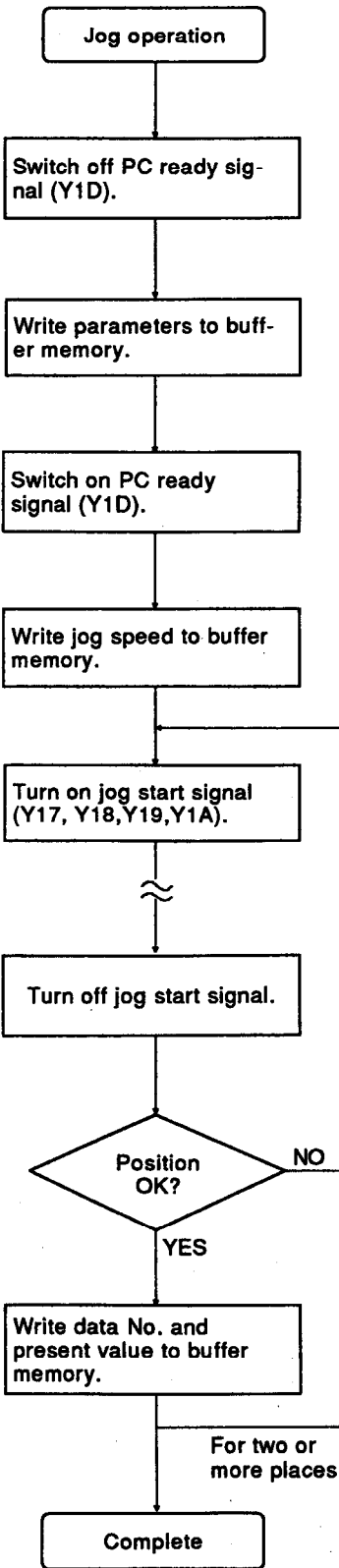

(2) Conditions

Table 6.7 Address Write Conditions Using Jog Operation

	Signal	State	Remarks
External signal	Drive unit READY	ON	
	Stop signal STOP	OFF	
Interface signal	AD71 ready (X1)	ON	*
	Relevant axis busy (X4, X5)	OFF	
	Relevant axis positioning commenced (X8, X9)	OFF	
	Relevant axis M code ON (XE, XF)	OFF	
	Relevant axis stop (Y15, Y16)	OFF	
	PC ready (Y1D)	ON	*
Others	Jog speed	Starting bias speed or higher	If jog speed specified is higher than the jog speed limit value, operation is performed at the jog speed limit value.
	Parameter		Must be within the permissible setting range.
			Neither axis should be BUSY after a BREAK signal has been received from the A6GPP and both axes have stopped.
			Neither axis should be BUSY after a STOP signal has been received from the AD71TU and both axes have stopped.

\* In the peripheral device test mode, X1 and Y1D may remain off.

(3) Timing

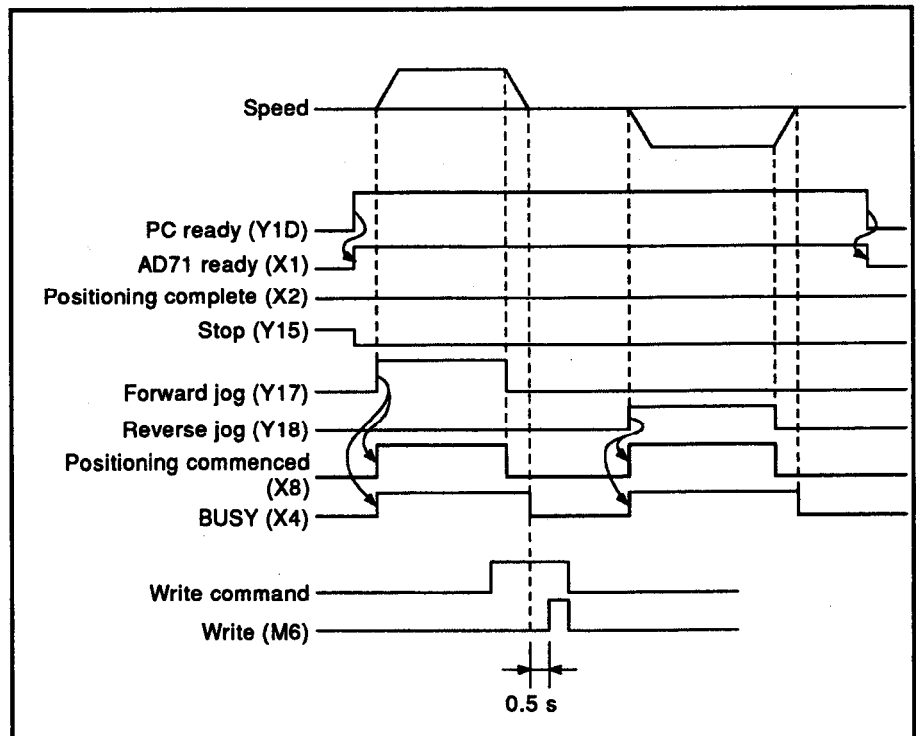



(4) Program

System is positioned in jog mode and resulting address written to buffer memory.

[Example]	X axis jog and address written as data No. 1 (jog speed = 2,000 (20,000 mm/min))																	
[Notes]	(1) Start conditions are shown in Table 6.7. (2) A delay of approx. 0.5 seconds occurs after positioning stops to allow the present value of the buffer memory to be updated.																	
[Data transfer]																		
<p style="text-align: center;">ACPU data register</p> <p>X axis jog operation speed      2000</p> <table border="1" style="margin-left: auto; margin-right: auto;"> <tr><td style="width: 40px; height: 15px;">D11</td></tr> <tr><td style="width: 40px; height: 15px;">D12</td></tr> </table>	D11	D12	<p>➡ (TO)</p> <p>← (FROM)</p> <p>➡ (TO)</p>	<p style="text-align: center;">AD71 buffer memory</p> <table border="1" style="margin-left: auto; margin-right: auto;"> <tr><td style="width: 40px;">Address</td><td style="width: 60px;">44</td></tr> <tr><td colspan="2" style="text-align: center;">⋯</td></tr> <tr><td></td><td>602</td></tr> <tr><td></td><td>603</td></tr> <tr><td colspan="2" style="text-align: center;">⋯</td></tr> <tr><td></td><td>5072</td></tr> <tr><td></td><td>5073</td></tr> </table> <p style="text-align: right;">} X axis present value</p> <p style="text-align: right;">} X axis data No.1 positioning address</p>	Address	44	⋯			602		603	⋯			5072		5073
D11																		
D12																		
Address	44																	
⋯																		
	602																	
	603																	
⋯																		
	5072																	
	5073																	

[Program]

To write address to data No.1

Creating necessary programs for AD71  
 [ Program for AD71(S1/S7) or A1SD71-S7 : Refer to Fig. 6.2-2. ]  
 [ Program for AD71S2 or A1SD71-S2 : Refer to Fig. 6.2-1. ]

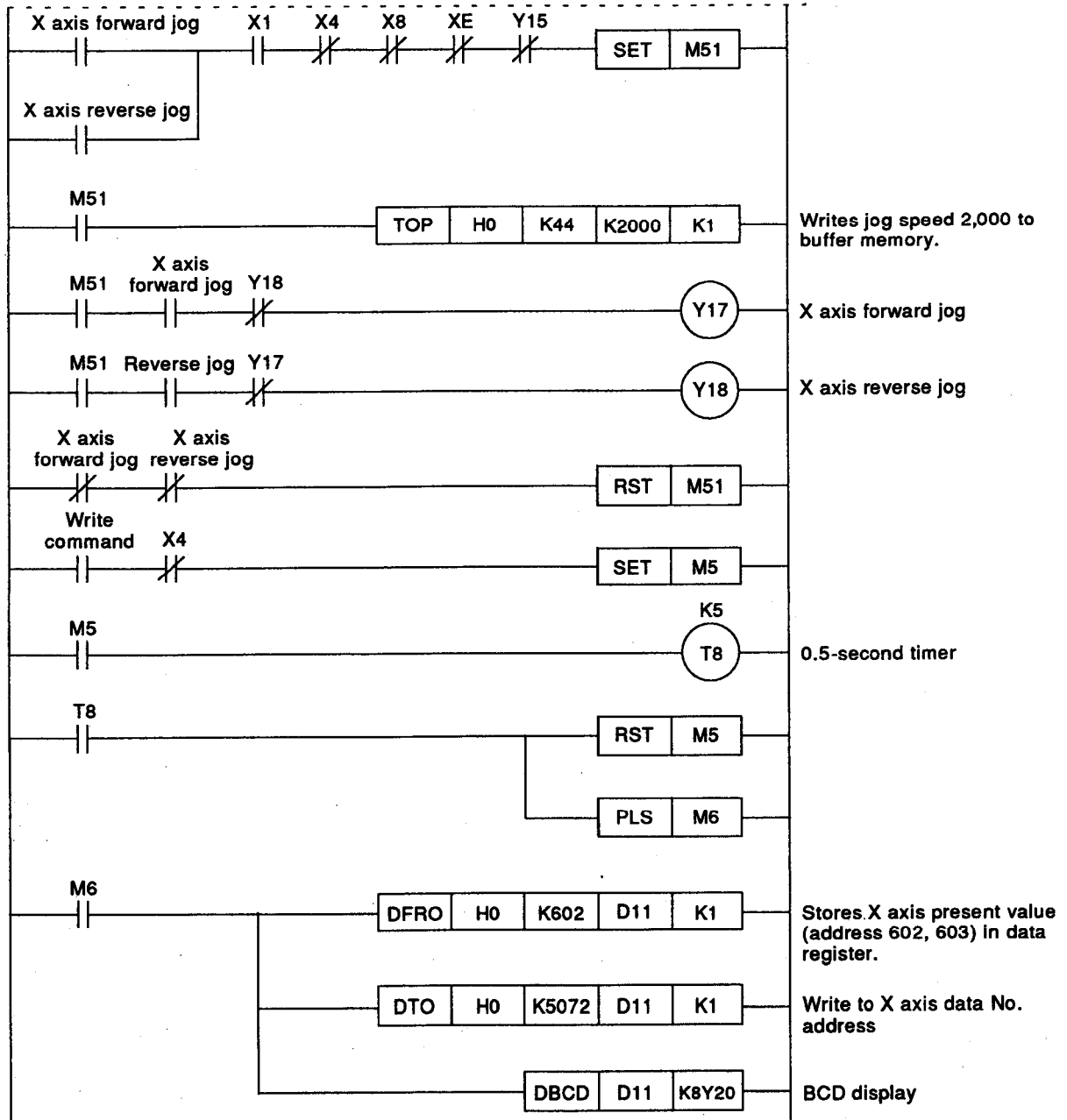

[2] Program for address writing using manual pulse operation

(1) Flow chart

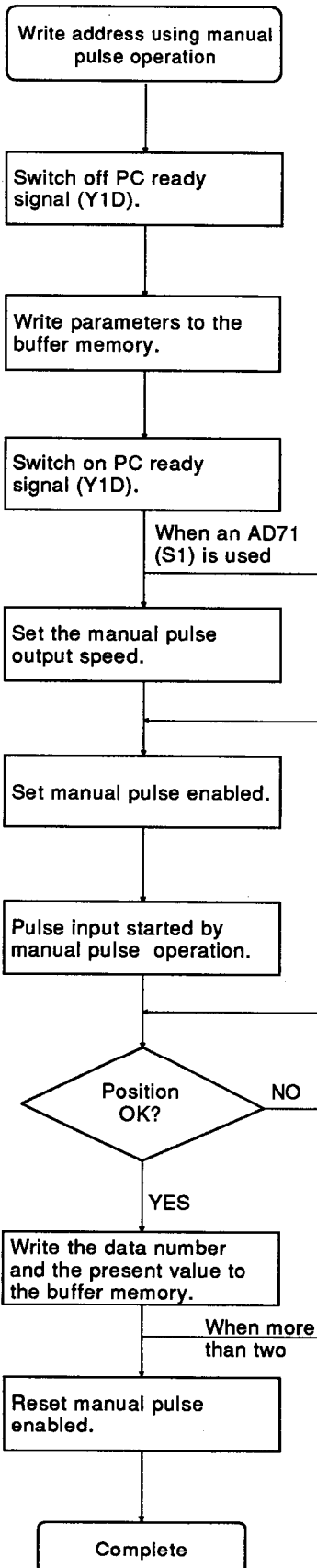

(2) Conditions

Table 6.8 Manual Pulse Operation Start Conditions

	Signal	State	Remarks
External signal	Drive unit READY	ON	
	Stop signal STOP	OFF	
Interface signal	AD71 ready (X1)	ON	*
	Relevant axis busy (X4, X5)	OFF	
	Relevant axis positioning commenced (X8, X9)	OFF	
	Relevant axis M code ON (XE, XF)	OFF	
	Relevant axis stop (Y15, Y16)	OFF	
	PC ready (Y1D)	ON	*
Others	Buffer memory "manual pulse enable" X axis: address 47 Y axis: address 347	0 bit = 1	When 0 bit = 0, pulse input by manual pulse generator operation will be ignored. It will not cause any error.
	Parameter	Within the setting range.	In the case of the AD71S7 and A1SD71-S7, the pulse output speed is adjustable.
	Buffer memory manual pulse output speed (202, 502)		
The relevant axis should not be BUSY after a BREAK signal has been transmitted from a peripheral device using the A6GPP function, or after a STOP signal has been transmitted from the AD71TU.			

\* In the peripheral device test mode, the signals may remain off.

(3) Timing

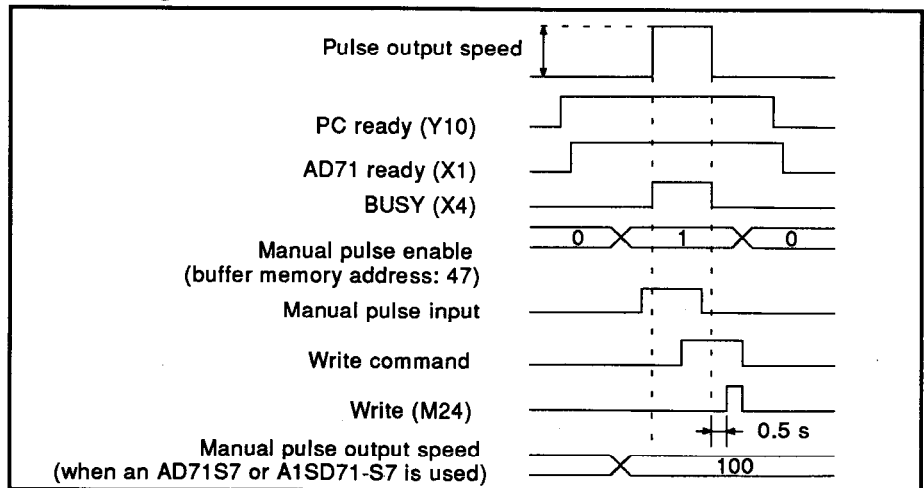

**IMPORTANT**

An error (code 73) will occur if manual pulse operation starts with manual pulse enabled set in the positioning, zero return or JOG operation mode while the relevant axis is BUSY. Write 0 (disabled) to the manual pulse enable area for modes other than the manual pulse mode.

(4) Program

Execute the specified positioning by manual pulse operation, and write the address as the designated data number.

[Example]	Writing address by X axis manual pulse operation as data No. 1
[Notes]	<p>(1) The start conditions are shown in Table 6.8.</p> <p>(2) After positioning stops, a delay of approximately 0.5 seconds applies for the present value in the AD71 buffer memory due to internal processing.</p>
[Data transfer]	<p>The diagram illustrates the data transfer process between the ACPU data register and the AD71 buffer memory. On the left, the ACPU data register contains two data points, D21 and D22. On the right, the AD71 buffer memory is organized into three sections:         <ul style="list-style-type: none"> <li><b>Address 47:</b> A single data point representing the manual pulse operation status. A legend indicates that "1" means "Manual pulse operation enabled" and "0" means "Disabled".</li> <li><b>X axis present value:</b> A two-point data block containing values 602 and 603.</li> <li><b>X axis data No. 1 positioning address:</b> A two-point data block containing values 5072 and 5073.</li> </ul>         Arrows indicate the direction of data flow:         <ul style="list-style-type: none"> <li>An arrow labeled "(TO)" points from the ACPU data register to the AD71 buffer memory at address 47.</li> <li>An arrow labeled "(FROM)" points from the AD71 buffer memory (specifically the present value section) back to the ACPU data register.</li> <li>An arrow labeled "(TO)" points from the ACPU data register to the AD71 buffer memory at addresses 5072 and 5073.</li> </ul> </p>

[Program]

Necessary program for AD71(S1/S7) or A1SD71-S7 (Refer to Fig. 6.2-2.)

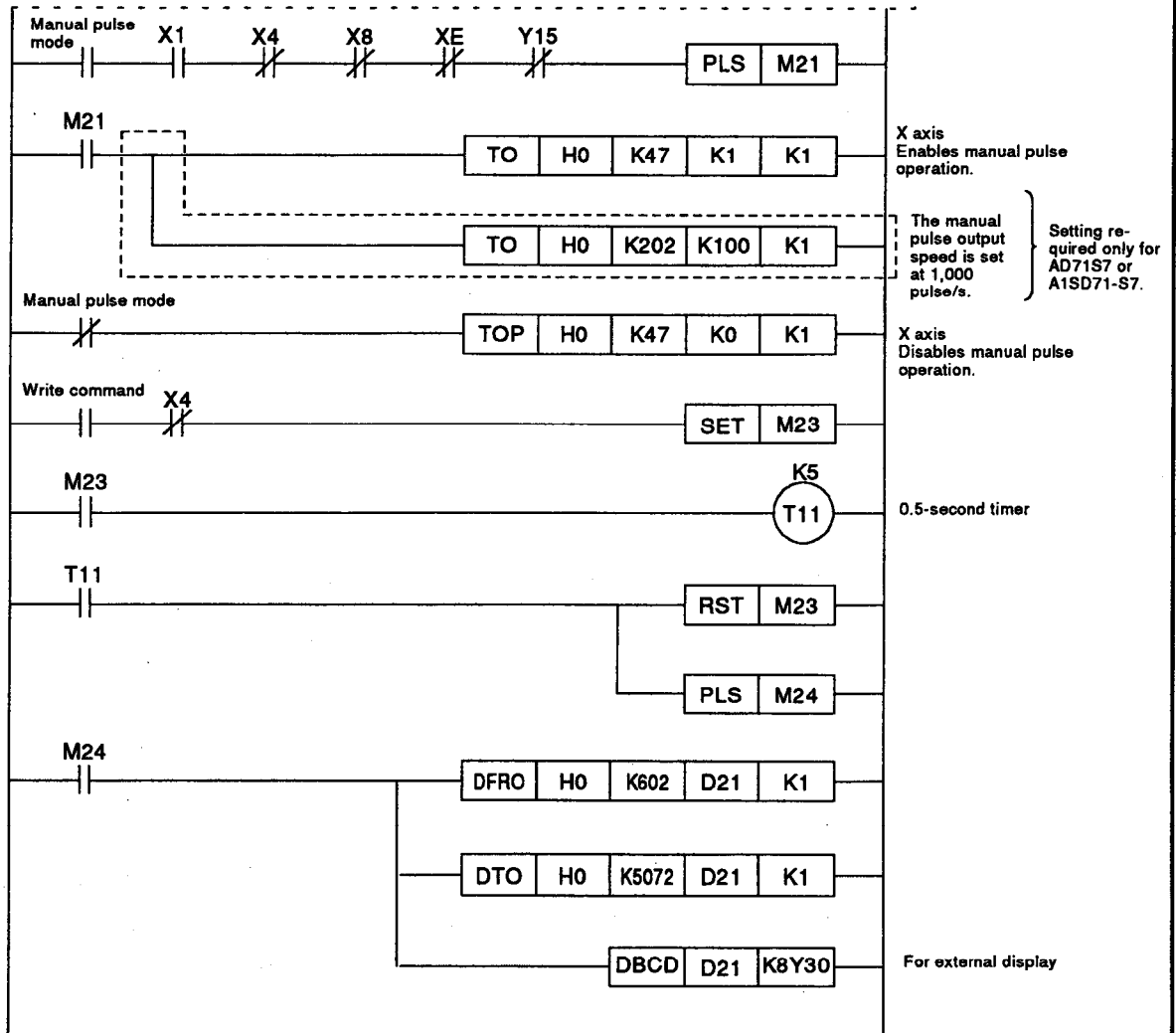

[3] Write the positioning addresses according to the data numbers entered with the digital switches.

Program example

Shown below is an example of a program for writing positioning addresses after positioning by JOG operation or manual pulse operation, to the specified buffer memory areas.

This example is based on the assumption that the data number is a 3-digit BCD code between X50 and X5B.

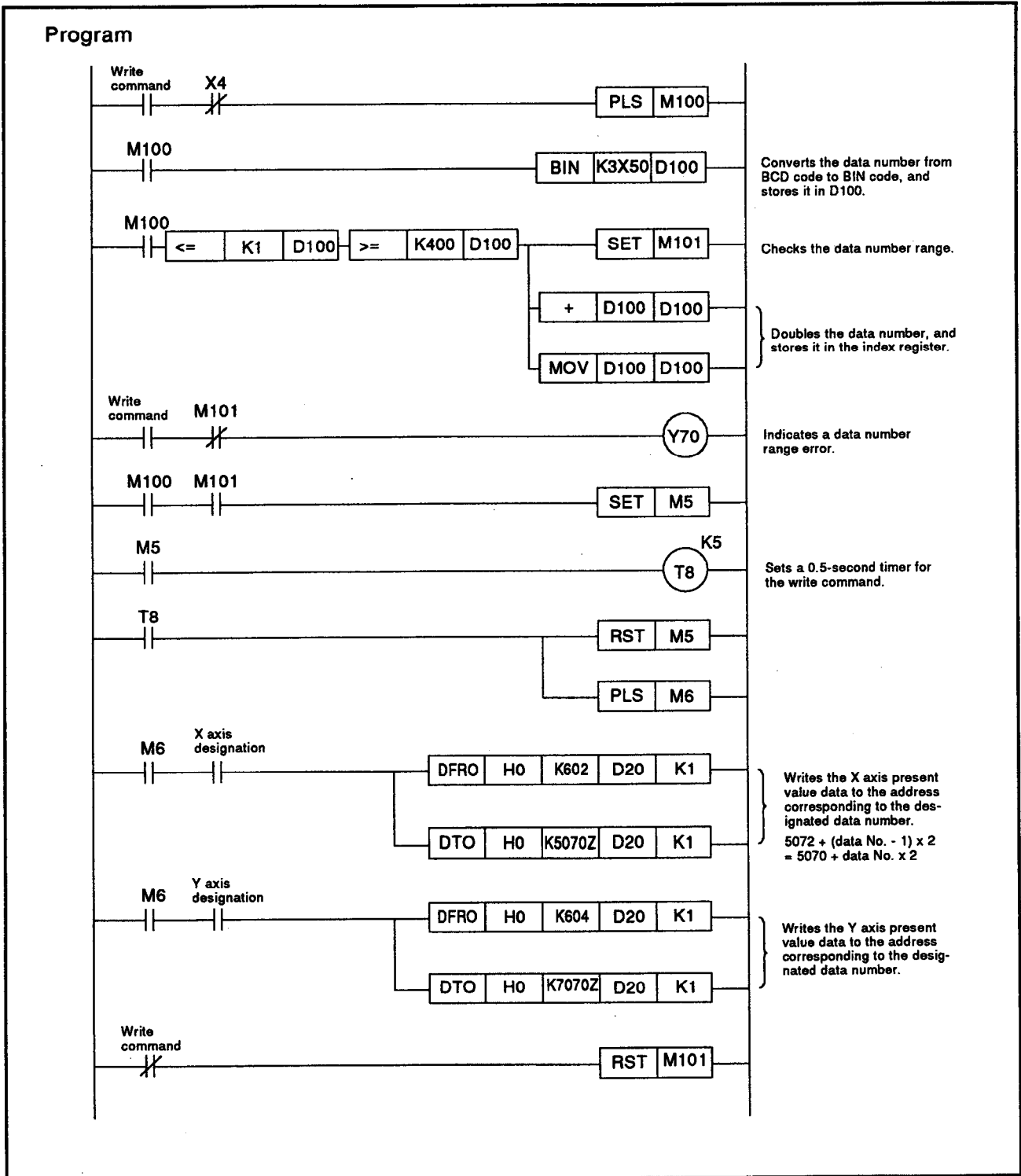

6.3.9 Zero return

(1) Flow chart

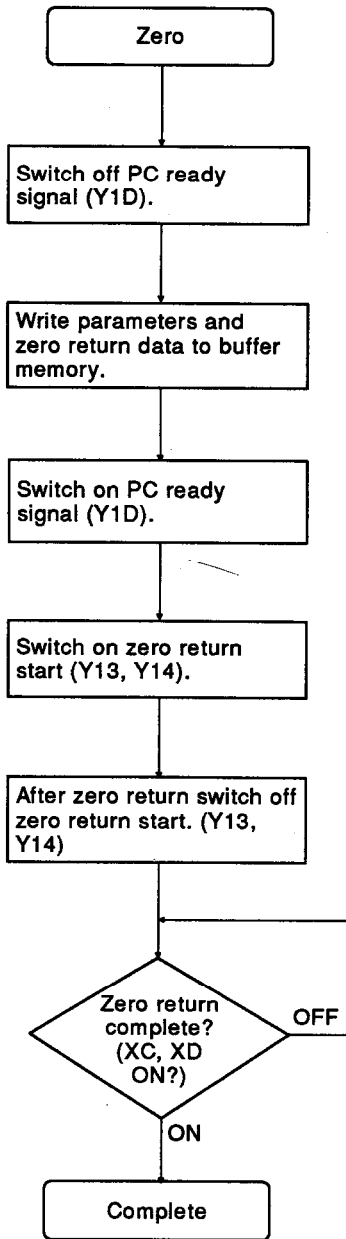

(2) Conditions

Table 6.9 Zero Return Conditions

	Signal	State	Remarks
External signal	Drive unit READY	ON	
	Stop signal STOP	OFF	
Interface signal	AD71 ready (X1)	ON	*
	Relevant axis busy (X4, X5)	OFF	
	Relevant axis positioning commenced (X8, X9)	OFF	
	Relevant axis zero return complete (XC, XD)	OFF	
	Relevant axis M code ON (XE, XF)	OFF	
	Relevant axis stop (Y15, Y16)	OFF	
	PC ready (Y1D)	ON	*
Others	Zero return data	No error	
	Repetition of zero return start	Max. twice consecutively.	
	Neither axis should be BUSY after BREAK (A6GPP) or STOP (AD71TU) has been received and positioning has stopped.		

\*In the peripheral device test mode, X1 and Y1D may remain off.

(3) Timing

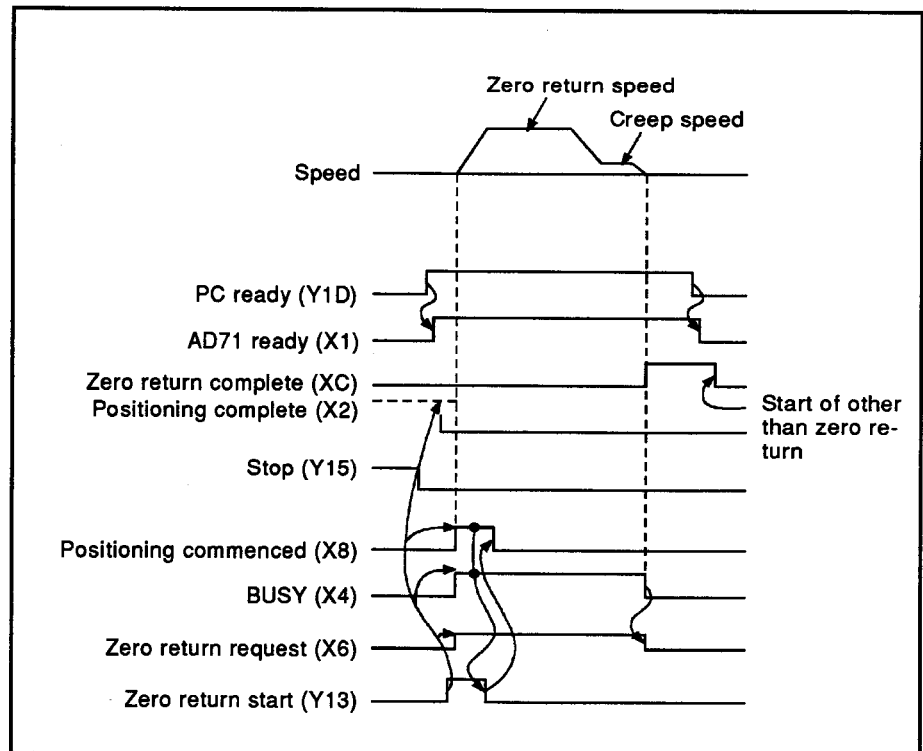

(4) Program

[Example] Zero return using a zero return command. (Note: When an error occurs, program execution is stopped and the error code is stored in the data register.)

- [Data transfer]
- (1) Start conditions are shown in Table 6.9.
  - (2) Interpolation operations are disabled during zero return.  
A delay of approx. 50 ms occurs at one axis when zero return is started at the X and Y axes simultaneously.
  - (3) Zero return cannot be repeated. When zero return is stopped, restart zero return after a jog operation or positioning operation.

[Program]

Creating necessary programs for AD71  
 [ Program for AD71(S1/S7) or A1SD71-S7 : Refer to Fig. 6.2-2. ]  
 [ Program for AD71S2 or A1SD71-S2 : Refer to Fig. 6.2-1. ]

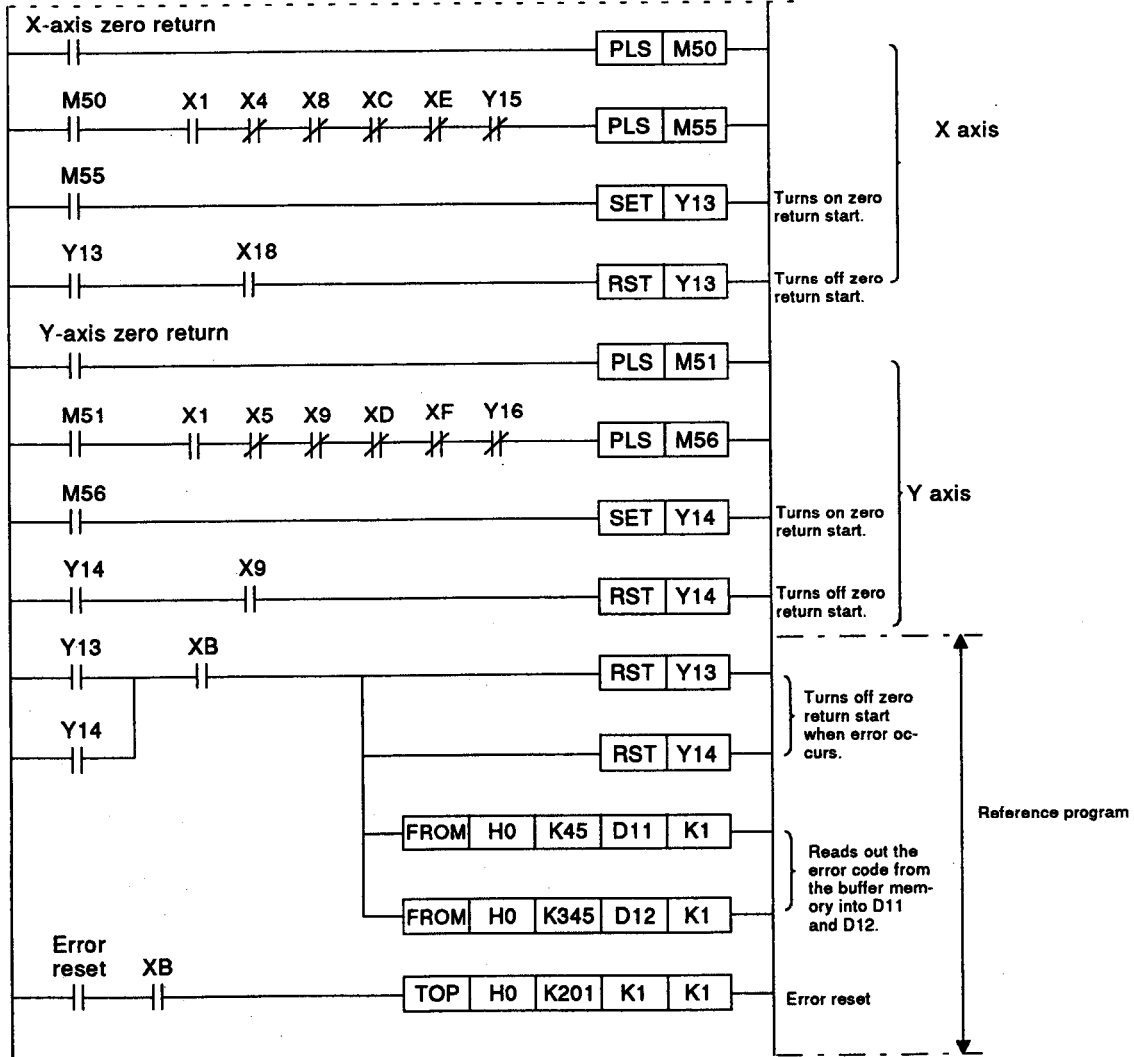



6.3.10 Present value change

(1) Flow chart

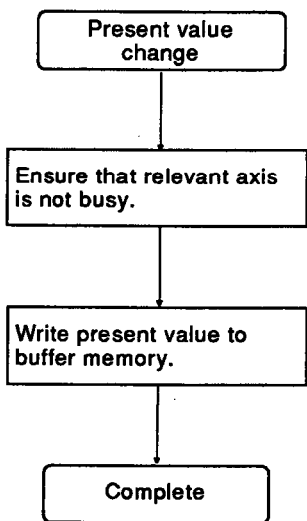

(2) Conditions

Table 6.10 Present Value Change Condition

Signal	State	Remark
Relevant axis BUSY	OFF	

(3) Program

**[Example]** To change the current value to 500 when the X-axis present value change command is switched form OFF to ON.

---

**[Data transfer]**

<p>ACPU data register</p> <table border="1" style="border-collapse: collapse; text-align: center;"> <tr><td style="padding: 2px;">D15</td></tr> <tr><td style="padding: 2px;">D16</td></tr> <tr><td style="padding: 2px;">D17</td></tr> <tr><td style="padding: 2px;">D18</td></tr> </table>	D15	D16	D17	D18	<p>⇒</p> <p>⇐</p>	<p>AD71 buffer memory</p> <table border="1" style="border-collapse: collapse; text-align: center;"> <tr><td style="padding: 2px;">Address</td><td style="padding: 2px;">41</td><td rowspan="2" style="padding: 2px;">} X-axis present value change data</td></tr> <tr><td></td><td style="padding: 2px;">42</td></tr> <tr><td></td><td style="padding: 2px;">≈</td><td></td></tr> <tr><td></td><td style="padding: 2px;">602</td><td rowspan="2" style="padding: 2px;">} X-axis present value (O, S)</td></tr> <tr><td></td><td style="padding: 2px;">603</td></tr> </table>	Address	41	} X-axis present value change data		42		≈			602	} X-axis present value (O, S)		603
D15																			
D16																			
D17																			
D18																			
Address	41	} X-axis present value change data																	
	42																		
	≈																		
	602	} X-axis present value (O, S)																	
	603																		

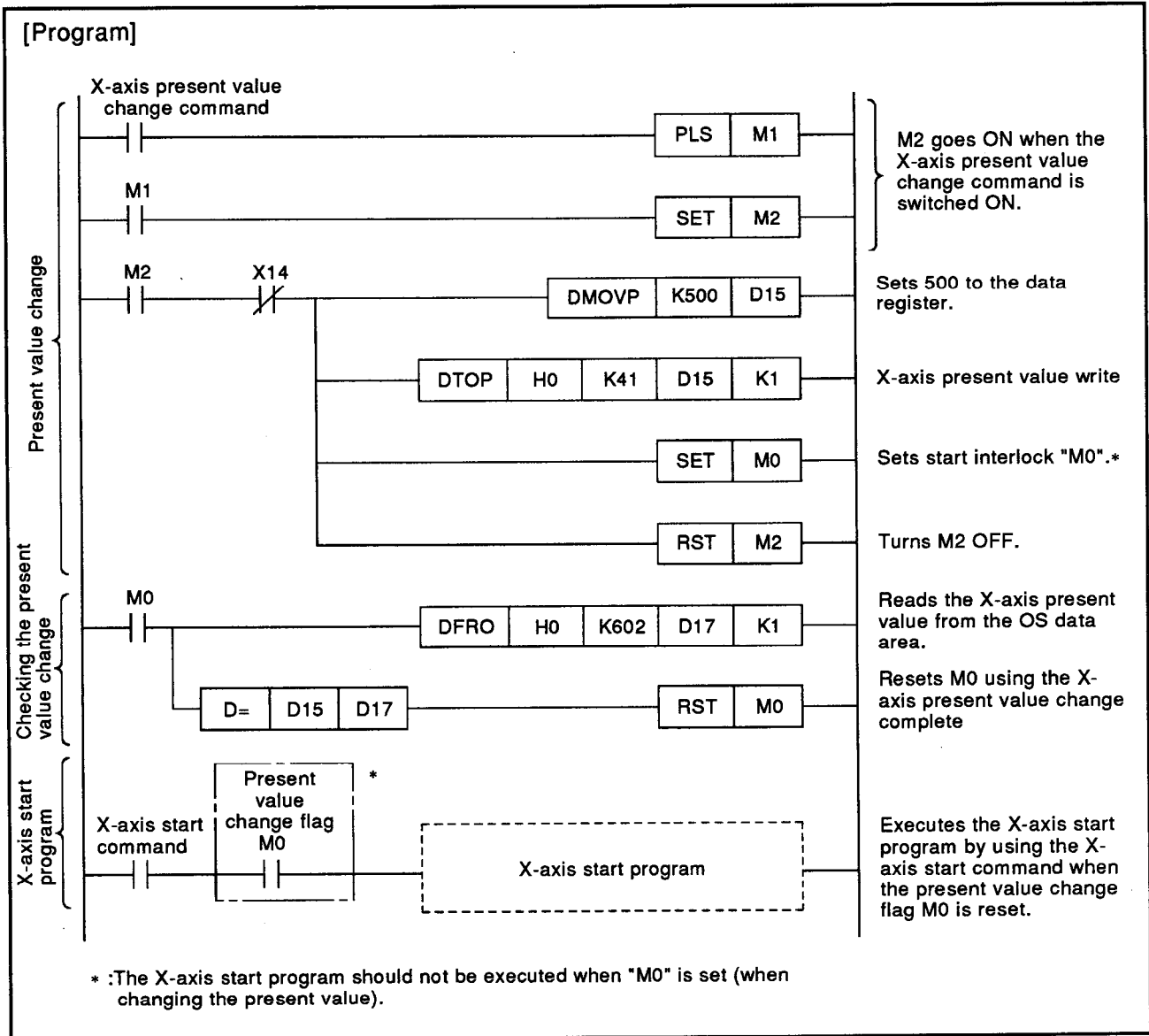

**REMARKS**

1. Data should be written to two words of the upper and lower digits in the present value change area. Writing to only one word causes an error, and the present value is not changed.
2. The present value is modified to a zero address by zero return after changing the present value. However, parameter and zero return data must be written before zero return.

6.3.11 Positioning stop

The positioning process may be stopped while the AD71 is busy as follows:

Table 6.11 Stop Signals

Item	Valid Signal	Independent Operation		Interpolation Operation
		Relevant Axis	Other Axis	
STOP signal from drive unit ON		○		○
PC ready signal (Y1D) OFF*		○	○	○
Stop signal from PC (Y15, Y16) ON*		○		○
BREAK key input from A6GPP or STOP key input from AD71TU		○	○	○

○ indicates that the signal is valid.

\* :In peripheral device test mode, positioning is not stopped if YD is ON or OFF.

(1) Note on use of stop signal

(a) Deceleration is valid after stop signal is received

On receiving any of the stop commands given in Table 6.11, the system is decelerated to a stop.

Arrange for stopping at upper and lower stroke limits and emergency stops to be controlled independently of the PC.

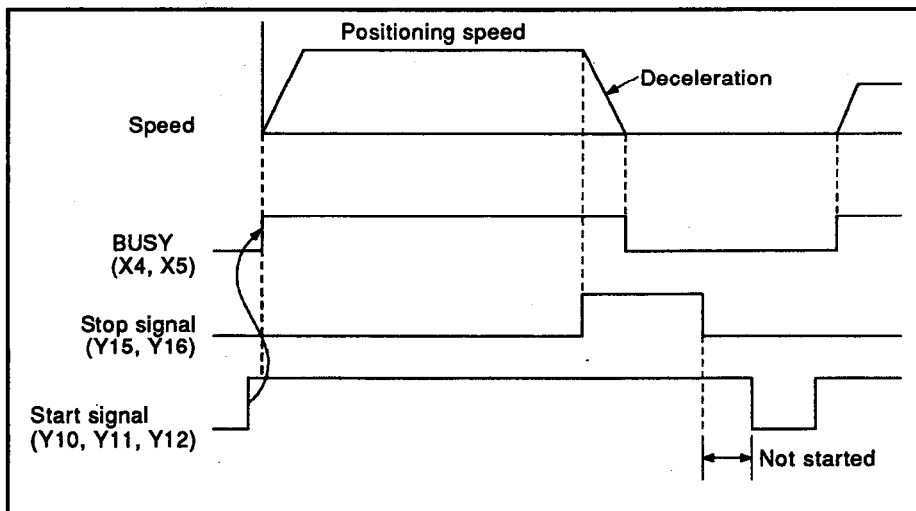

Fig. 6.8 Stop Signal

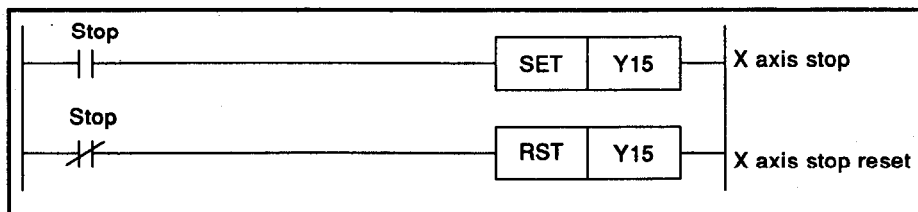

Fig. 6.9 Stop Program Example

(b) Stop signal during deceleration

The operation decelerates and stops at that speed except in the following cases.

- 1) When zero return is executed, only the stop signal during deceleration is stopped.

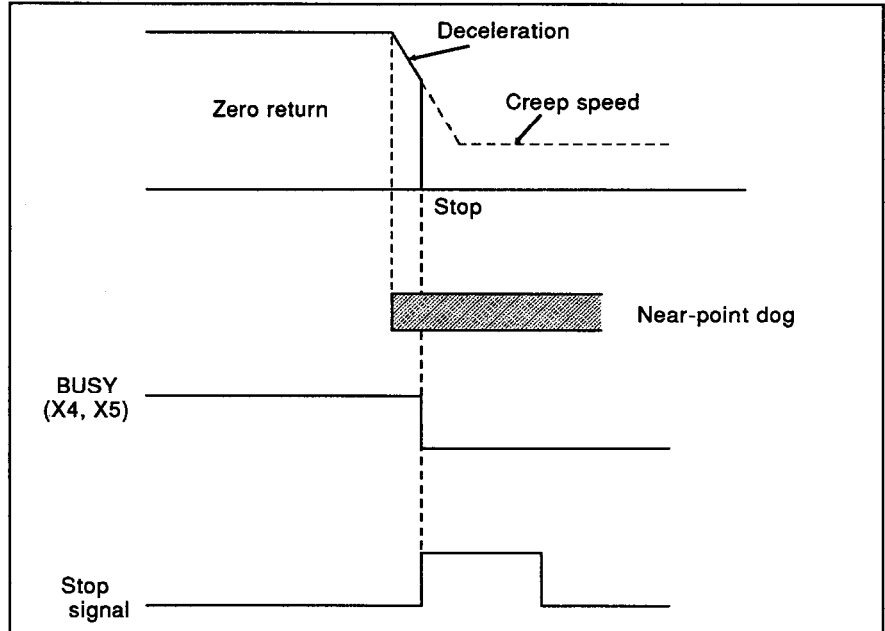
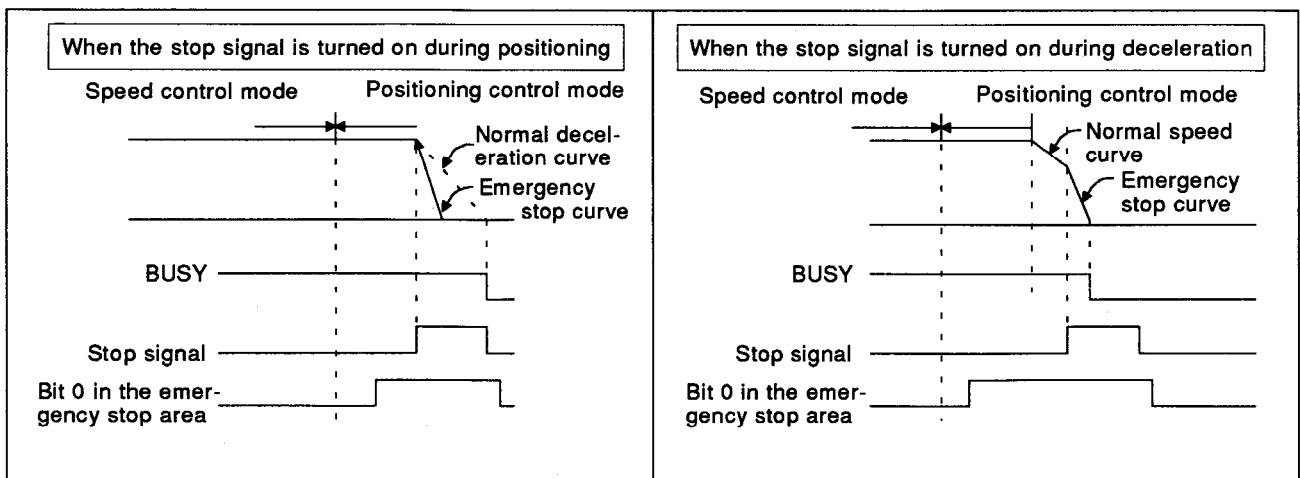

Fig. 6.10 Stop Command Received During Zero Return Deceleration

**REMARK**

In the case of a stop when the stop signal is turned ON after the near-point dog for zero return, return to the position prior to the zero-point dog by jog operation, and retry. Otherwise, the A1SD71 can malfunction.

- 2) When bit 0 in the emergency stop area is set to 1 in the speed/positioning control switching mode when using an AD71S2 or A1SD71-S2, the deceleration curve changes to the emergency stop curve.



(c) Stop signal reset

A start signal (Y0, Y1, Y2) is only valid at its leading edge, therefore if it is already on when the stop signal is reset the process will not restart.

(d) M code

The conditions shown in Table 6.11 turn off the M code ON signal at the relevant axis. When the PC ready signal is turned off, the M code is set to "0".

(e) Stop during interpolation operations

During interpolation operations, both axes can be stopped by either the X- or the Y-axis stop signal. However, when interpolation and independent operations are combined in the start data number automatic switching (pointer setting), the axis stops as shown below at the point update. Therefore, after going to independent positioning, the stop signal is only valid for the self axis.

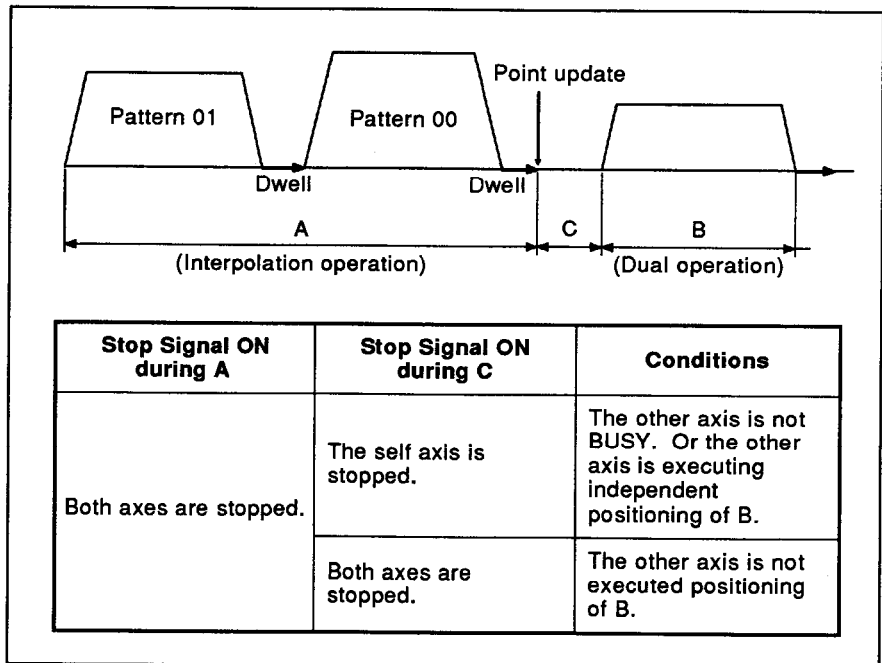

Fig. 6.11 Stop during Interpolation

(2) Other stop signals

In addition to the four stop signals in Table 6.11, the following also stop processing while the AD71 is BUSY. For all the following, positioning is decelerated to a stop and the A6GPP displays an error message.

Table 6.12 Stop Signals

Item	Valid Signal	Independent Operation		Interpolation Operation
		Relevant Axis	Other Axis	
Ready signal from drive unit OFF		○		○
Operation error (8231 error)		○	○	○
AD71 bus error		○	○	○

- (3) Restarting after a stop
  - (a) Proceed to the next address

The table below shows when data number automatic switching is used and not used.

	Absolute Method	Incremental Method
	Two Axes Independent Operation/ Two Axes Interpolation Operation	Two Axes Independent Operation/ Two Axes Interpolation Operation
Data number automatic switching is used.	Available	Unavailable
Data number automatic switching is not used.	Unavailable	Unavailable

**REMARK**

Apply the following processes for the unavailable mode:

- Restart after zero return.
- Restart after resetting the positioning data.
- When setting the data number to the 1st point (X-axis address: 0, Y-axis address: 300) in the AD71S7 positioning start data area, data number automatic switching is not used.
- When setting several data numbers to the AD71S7 positioning start data area (X-axis addresses: 0 to 39, Y-axis addresses: 300 to 339), data number automatic switching is used.

- 1) When data number automatic switching is not used in the absolute method.

The executing data number is stored to buffer memory addresses 48 (X axis) and 348 (Y axis) during positioning and kept until the next start. This applies to the restart after stop.

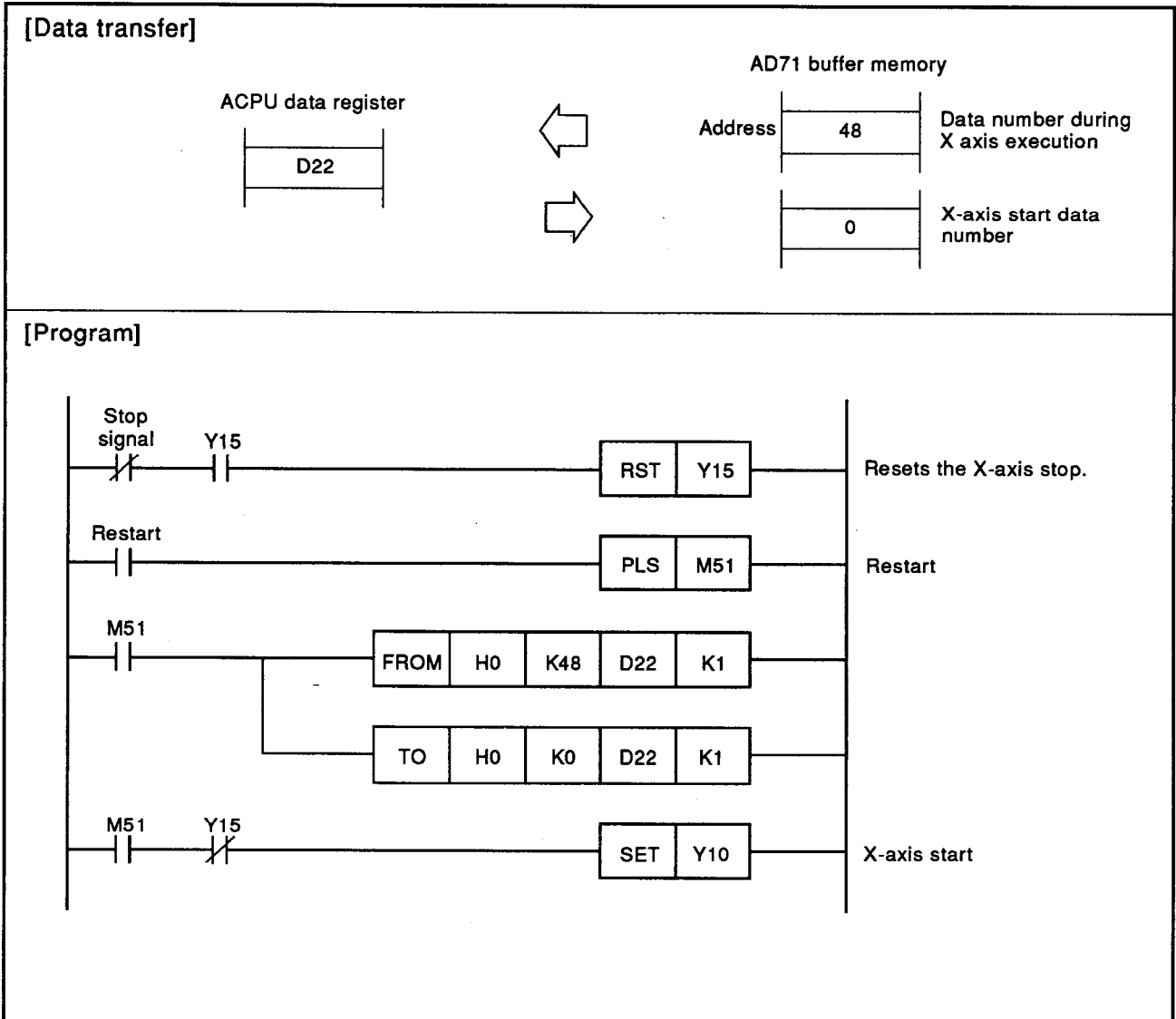

(b) Zero return method

Refer to Section 6.3.9.

(c) Restarting after a stop during zero return

Zero return starts cannot be repeated. Execute zero return after the following operations.

- 1) Execute positioning from the correct data number.
- 2) Execute positioning using a jog operation when positioning is stopped near the zero point.

(d) Positioning is stopped by using the BREAK key on the A6GPP.

BREAK key is valid for the X and Y axes. Positioning can be restarted when both axes are not BUSY. If one axis is BUSY, starting is disabled.



### 6.4 ACPU Remote I/O Station Programming

This section explains the programming of the master station (ACPU) when the AD71 is loaded in a remote station.

#### 6.4.1 Notes on programming

Data communication with a remote I/O station is on a batch refresh basis after the END (or FEND) instruction is executed in the master station program.

Note the following points when loading an AD71 in a remote I/O station:

For detailed data link specifications, refer to the Data Link Unit User's Manual.

- (1) There is a short time delay in the communication of control data between master and remote I/O stations which must be allowed for when specifying the system.
- (2) The following data communication instructions are used between master and remote stations:

Data write from master to AD71 : RTOP instruction

Data read from AD71 to master : RFRP instruction

Link registers (W) are used for data communication between the master station CPU and the AD71. Therefore, it is necessary to write a program to perform the following processing: (a) transfer the data stored in the link registers to other devices after execution of the RFRP instruction, and (b) write the data that is to be transferred, to the link registers, before execution of the RTOP instruction.

- (3) The RTOP and RFRP instructions cannot be executed in the same scan for one AD71 in a remote I/O station. (These may be used in the same scan if addressed to separate AD71 units.)

(When two AD71s are loaded in a remote I/O station, an RTOP instruction for AD71 number one can be executed simultaneously (i.e. within the same scan) with an RFRP instruction for AD71 number two.)

All data communication must therefore be interlocked as shown in the examples that follow.

I/O numbers have been assigned as X0 to 1F and Y0 to 1F.

- (4) AD71 control signals
  - Due to the relationship between the master station scan time and the link scan time, Y[ ][ ] may not be output to the remote I/O station by PLS Y[ ][ ].
  - Since data is communicated between the master station and the remote I/O stations in the batch refresh mode after the END (FEND) instruction is executed, pulse output cannot be used to execute the RST instruction subsequent to the SET instruction.

Signal Direction: PC CPU to AD71		Signal Direction: AD71 to PC CPU	
Device No.	Signal	Device No.	Signal
Y0 to YC	Reserved	X10 to X1C	Reserved
YD	Switches X1D off	X1D	On indicates AD71 fault. RFRP and RTOP instructions cannot be used.
YE	Switched on by master station CPU when RFRP instruction is executed (data transferred from link unit to master station CPU). To be reset in user program after ensuring that X1E is on.	X1E	On while AD71 in remote station is processing RFRP instruction.
YF	Switched on by master station CPU when RTOP instruction is executed (data transferred from master station CPU to link unit). To be reset in user program after ensuring that X1F is on.	X1F	On while AD71 in remote station is processing RTOP instruction.

Timing

AD71 fault. RTOP and RFRP instructions cannot be used.

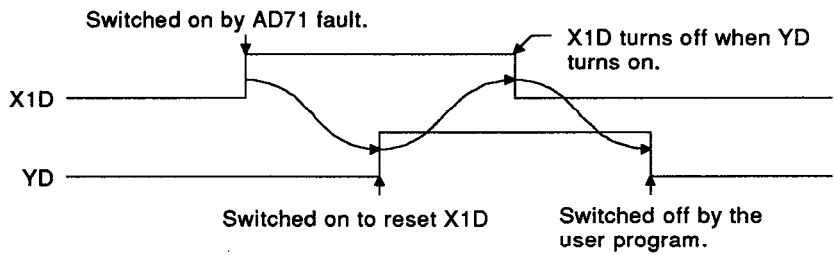

Execution of RFRP instruction

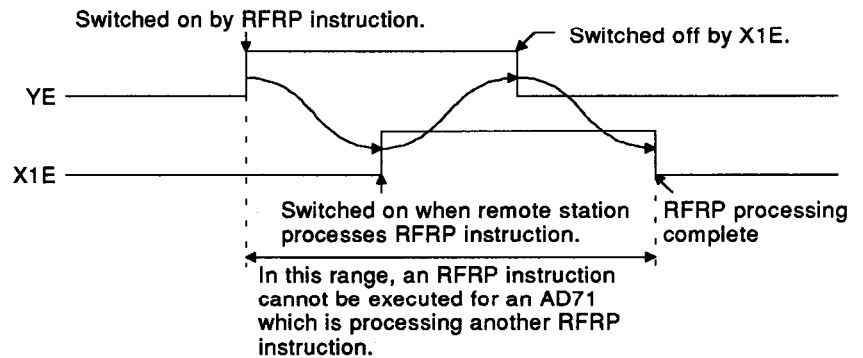

Execution of RTOP instruction

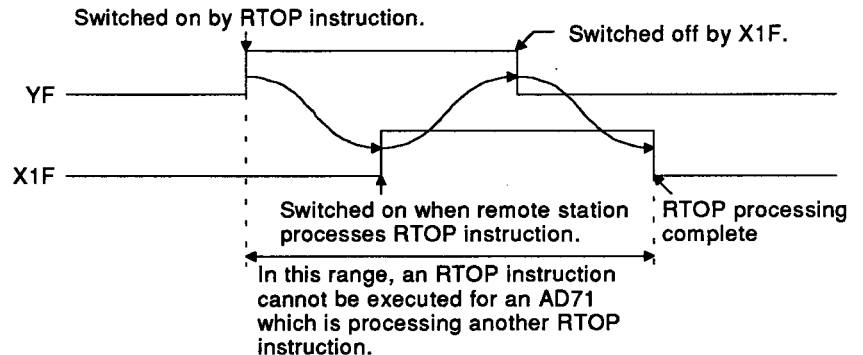

## 6.4.2 Reading and writing data

### (1) Read from remote I/O station

[Format]

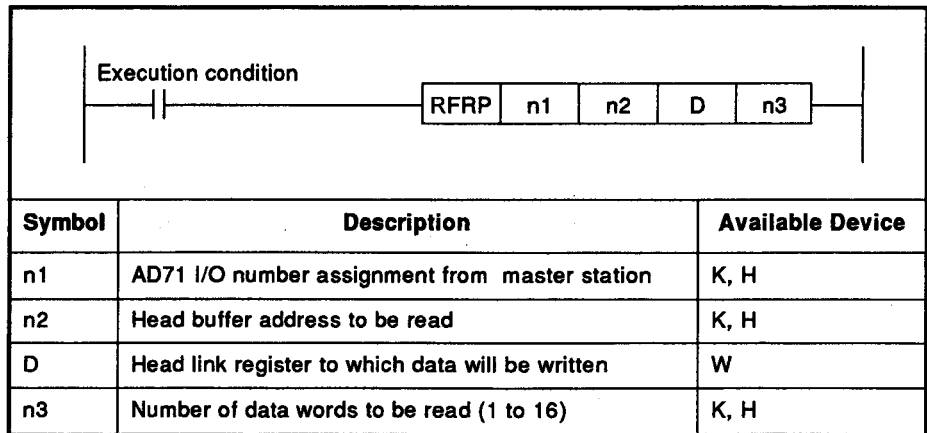

#### POINT

Set the I/O number identified from the master station as the head I/O number in n1 for the RFRP and RTOP instructions. (The number is different from the upper two digits designated for FROM/TO instructions.)

Example: Reading one word from buffer address 600 of the AD71 located at I/O address X, Y130 to 14F in a remote I/O station.

To read once on receiving the start signal

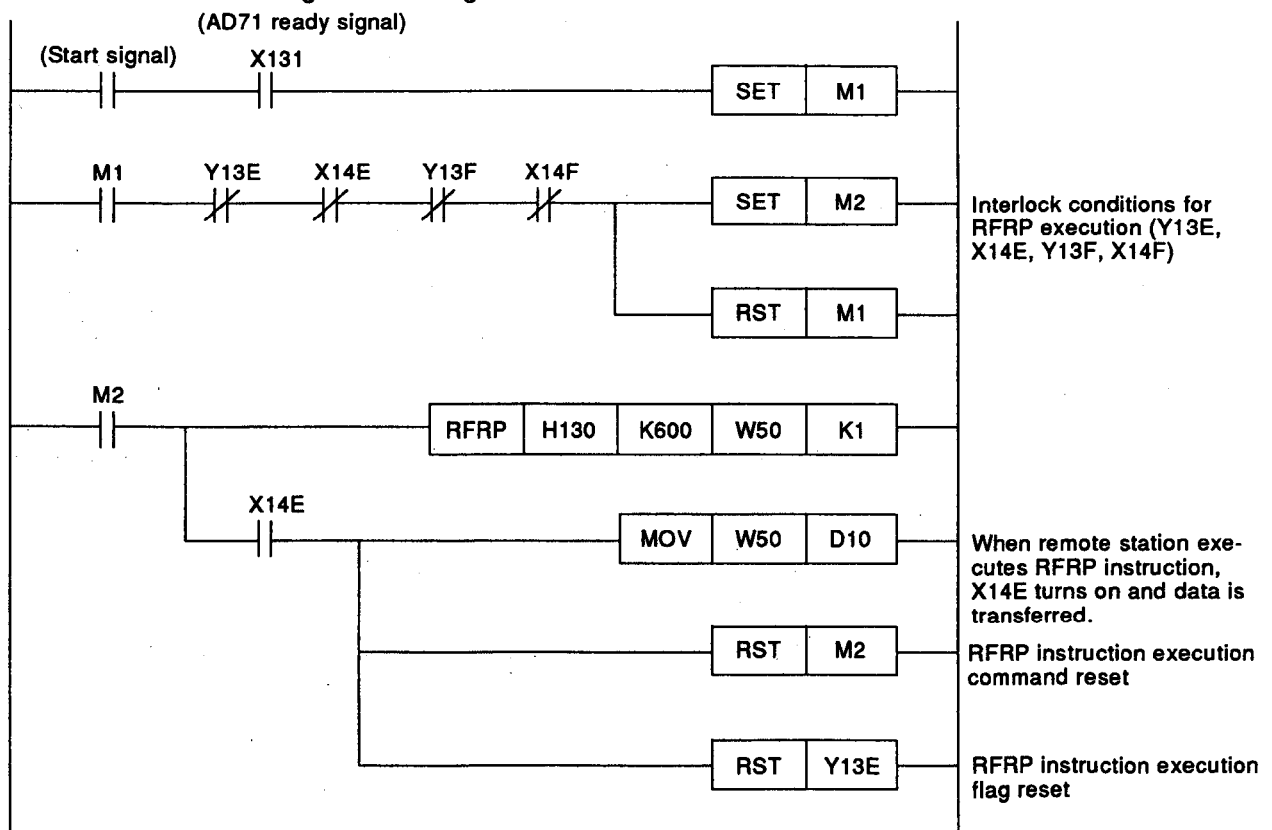

# 6. PROGRAMMING

To continually read while start signal is on.

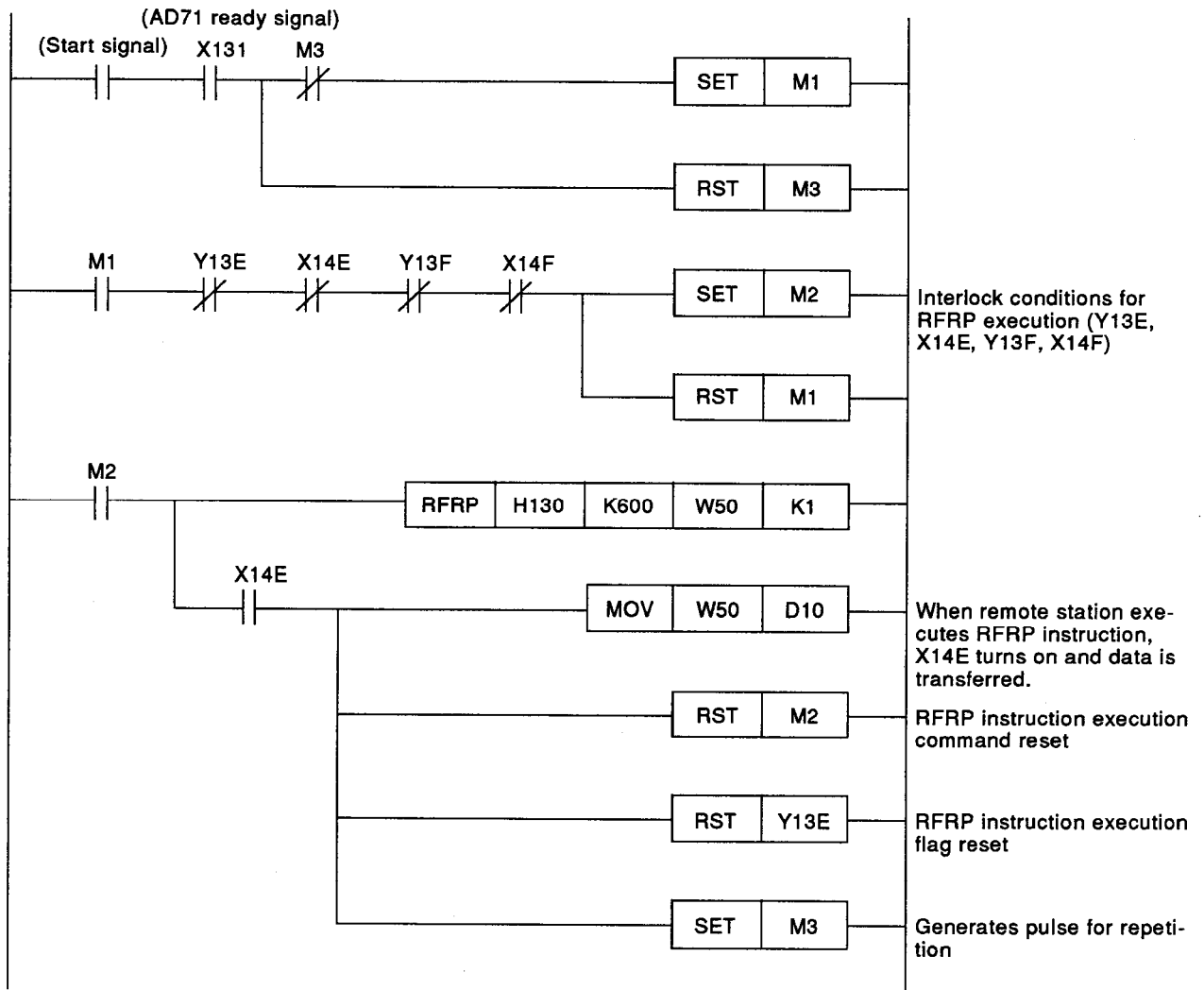

(2) Write to remote I/O station AD71

[Format]

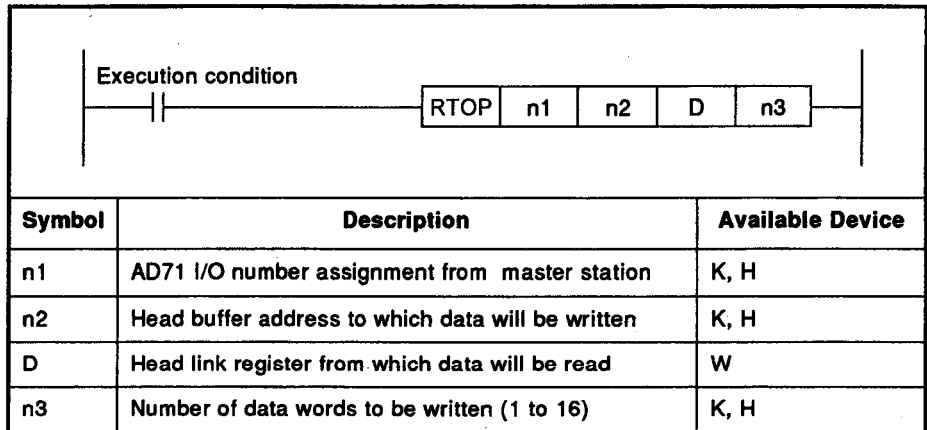

**POINT**

Set the I/O number identified from the master station as the head I/O number in n1 for the RFRP and RTOP instructions. (The number is different from the upper two digits designated for FROM/TO instructions.)

Example: Writing two words to buffer address 602 and 603 of the AD71 located at I/O address X, Y130 to 14F in a remote I/O station.

To write once on receiving the start signal

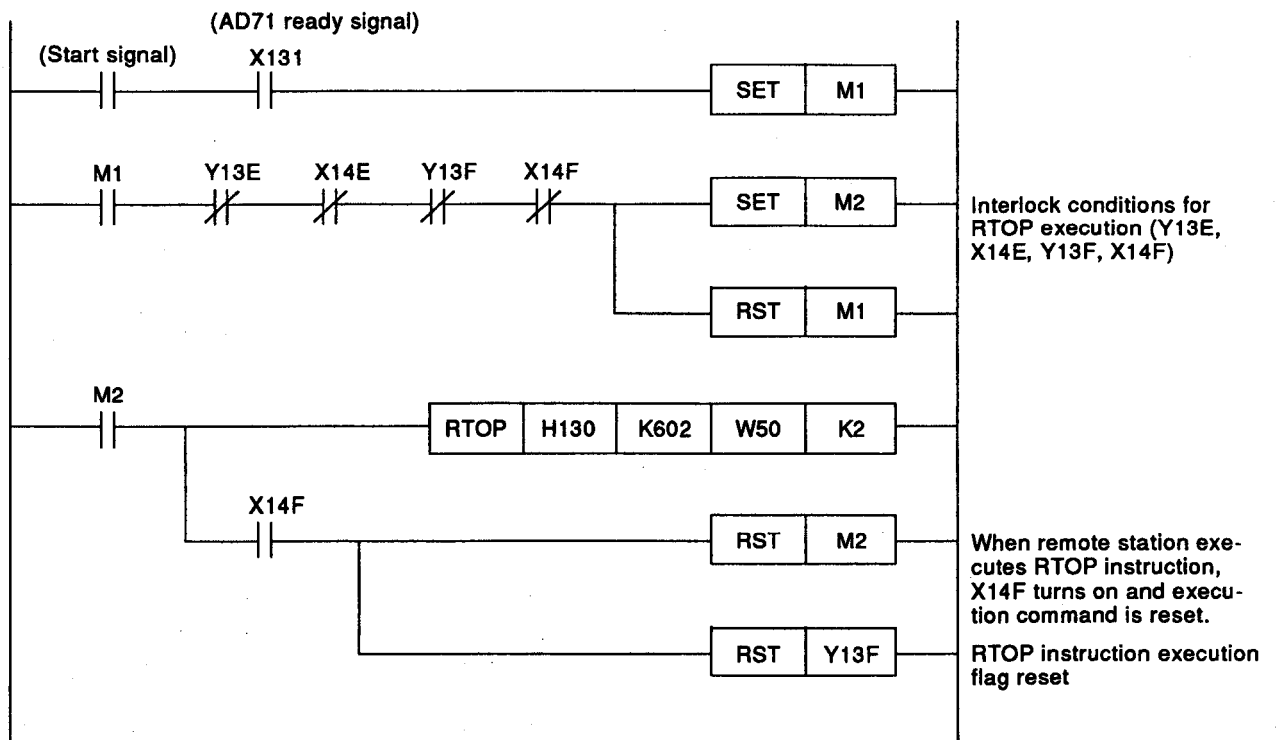

6.4.3 Program example

This section shows an example of a program for starting X and Y axes, interpolation and zero return.

The preconditions are listed below:

- (1) All parameters, zero return data and positioning data have been written to the AD71 loaded in the remote I/O station from a peripheral device.
- (2) The AD71 has been assigned to X, Y100 to 11F, as seen from the master station.
- (3) Sixty-four link registers (W100 to 13F) have been allocated to RTOP instructions, and sixty-four (W200 to 23F) to RFRP instructions.
- (4) Data number pointers, etc. have been written to the link registers.

(1) Link parameters

\* LINK \*

MASTER	SLAVE PC STATIONS	M → ALL L		W.D.T FOR LINK 10ms	INTER-MITTENT 10ms	M : B ↔ ALL L : B -	
		B	W			M : W ↔ ALL L : W -	M : W → ALL R : W 100 - 13F
M	1	-	-	28	XXXX	M : W ← ALL R : W 200 - 23F	M : Y → ALL L : X -
						M : Y → ALL R : Y 100 - 11F	M : X ← ALL L : Y -
						M : X ← ALL R : X 100 - 11F	

  

L/R NO.	M ← L		M → R	M ← R	M → L/R		M ← L/R	
	B	W	W	W	Y	X/Y	X	Y/X
R 1	-----	-----	100 - 13F	200 - 23F	100 - 11F	000 - 01F	100 - 11F	000 - 01F
	-	-	-	-	-	-	-	-
	-	-	-	-	-	-	-	-
	-	-	-	-	-	-	-	-
	-	-	-	-	-	-	-	-
	-	-	-	-	-	-	-	-

M : MASTER L : LOCAL R : REMOTE I/O

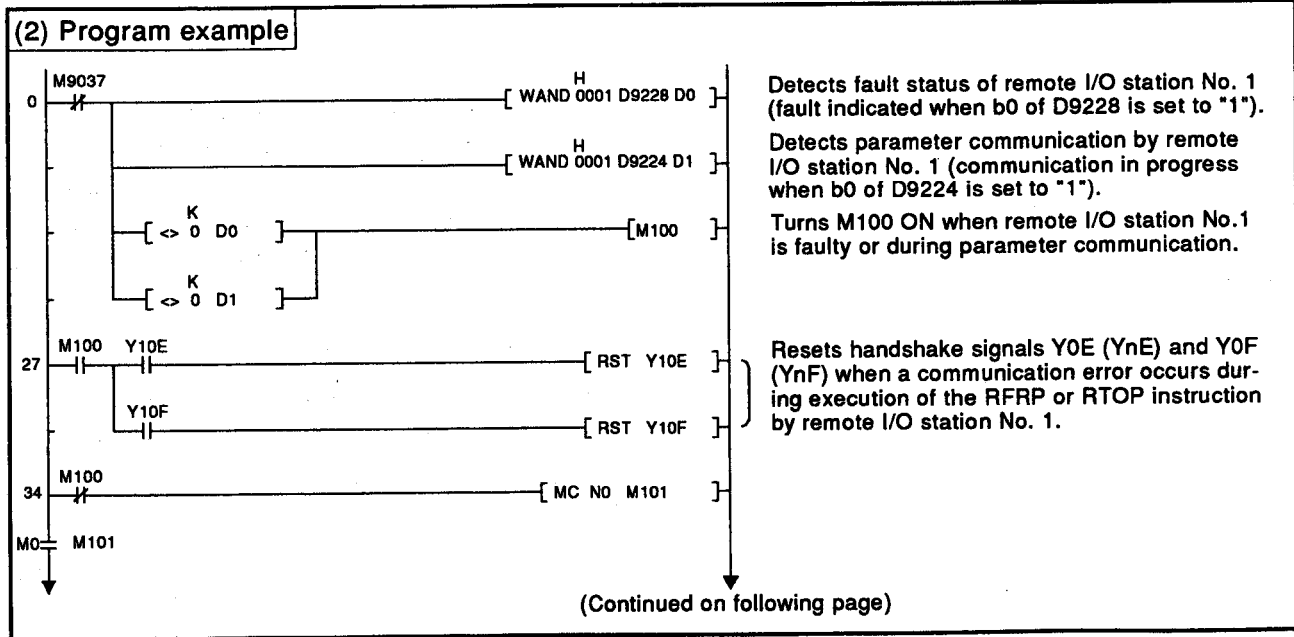

(Continued from preceding page)

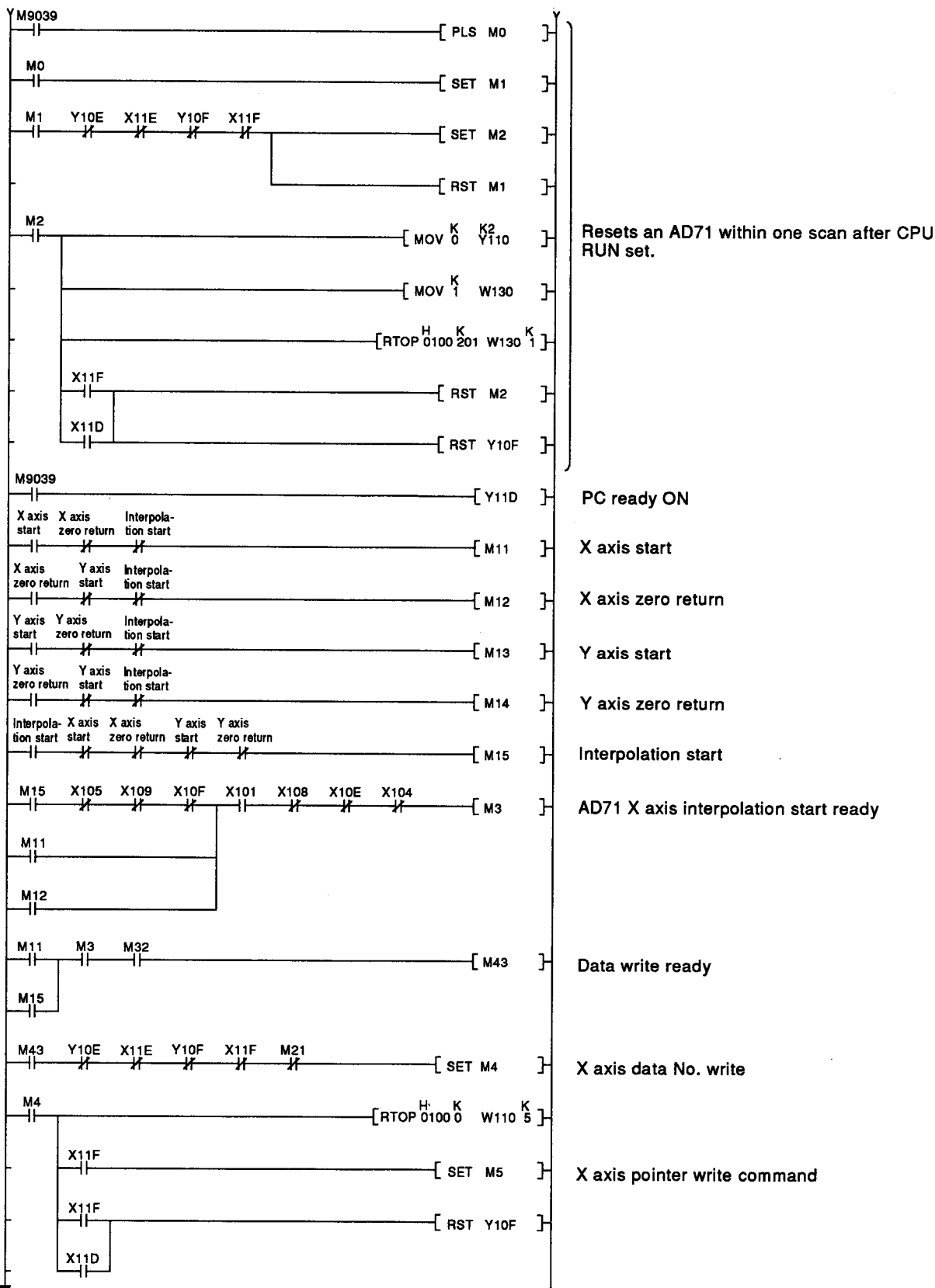

Resets an AD71 within one scan after CPU RUN set.

PC ready ON

X axis start

X axis zero return

Y axis start

Y axis zero return

Interpolation start

AD71 X axis interpolation start ready

Data write ready

X axis data No. write

X axis pointer write command

(Continued on following page)

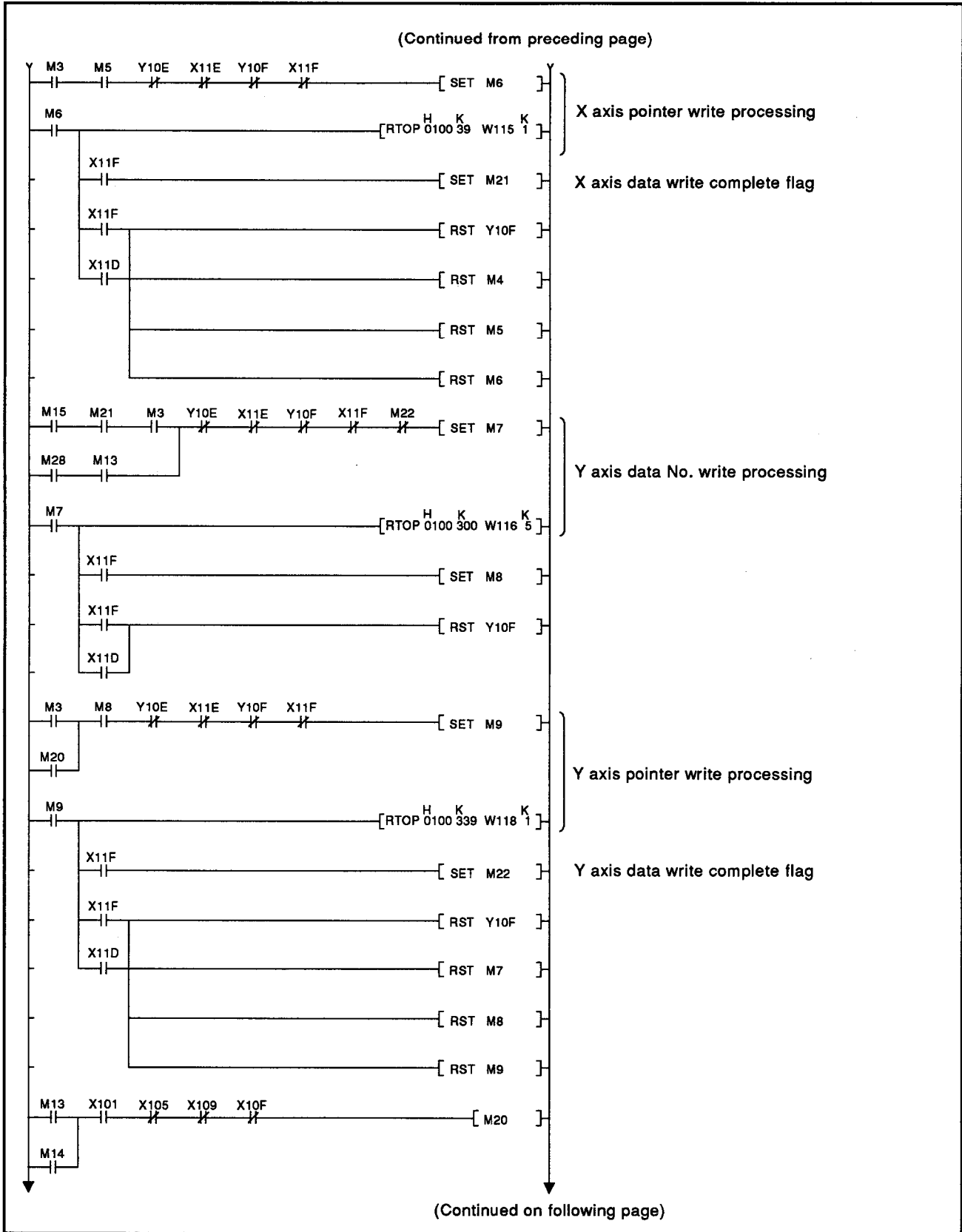



(Continued from preceding page)

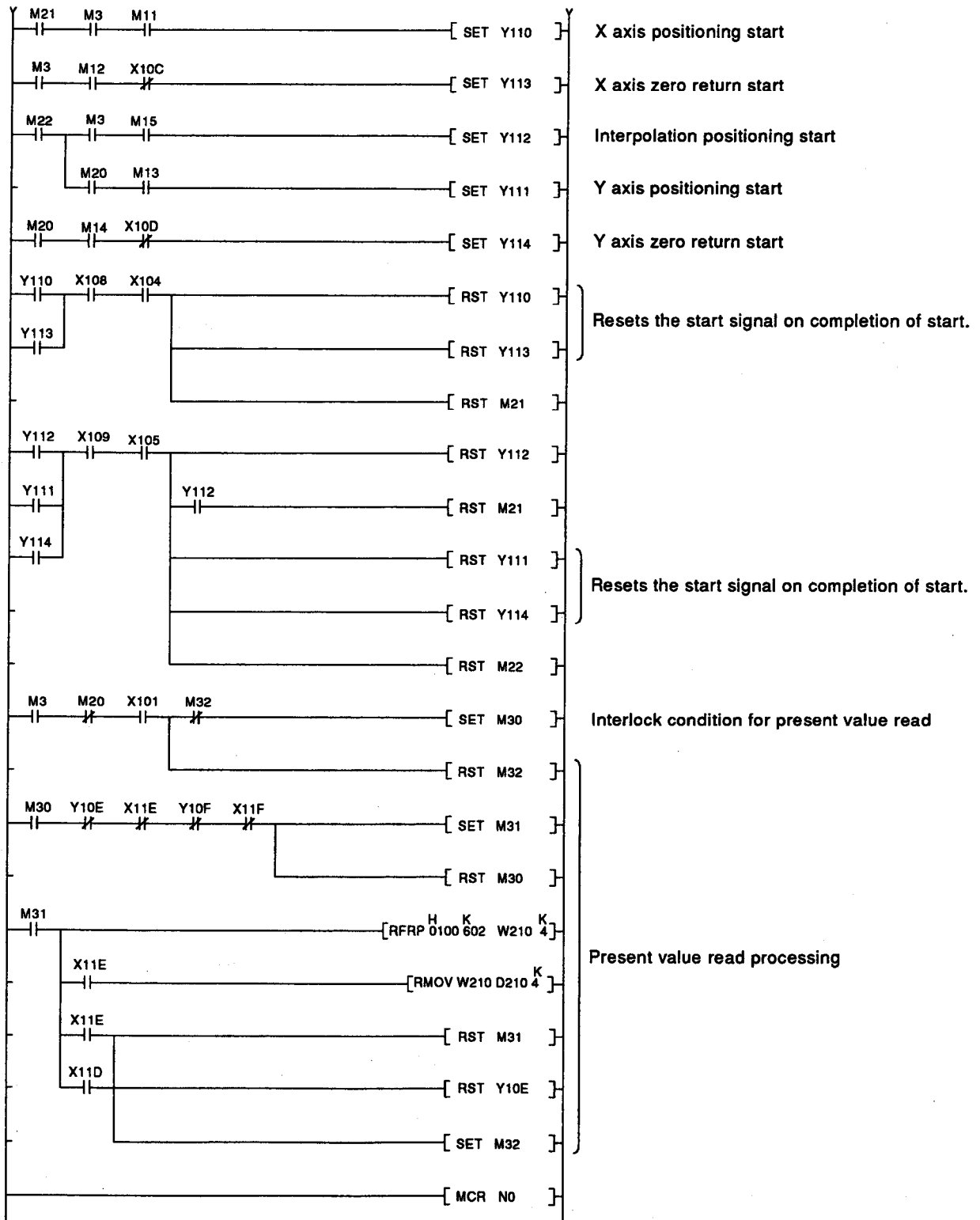

CIRCUIT END

## 7. TRIAL OPERATION AND ADJUSTMENT

This chapter describes the instructions for trial operation and adjustment of the AD71. Since the positioning module is used with an A series CPU, refer to the section on trial operation and adjustment in the CPU User's Manual as well.

### 7.1 General Check List

Before testing the AD71, check the following:

**Table 7.1 General Check List**

	Check Point	Description	Check
1	Battery	<ul style="list-style-type: none"> <li>• Check that the lead wire connectors, which were disconnected on delivery, are connected to the corresponding pin connectors on the PC board.</li> </ul>	
2	Parameter setting	<ul style="list-style-type: none"> <li>• Check that zero return data has been set.</li> <li>• Check that values are correct.</li> </ul>	
3	Zero return data setting	<ul style="list-style-type: none"> <li>• Check that positioning data has been set.</li> <li>• Check that values are correct.</li> </ul>	
4	Positioning data	<ul style="list-style-type: none"> <li>• Check that parameters have been set.</li> <li>• Check that values are correct.</li> </ul>	

#### **POINT**

If only one axis (X or Y axis) is used, parameters and zero return data must be written to the unused axis. Otherwise zero return will result in error and switch on the X0B (error detection) signal.  
 (Data written must be within the range given in the User's Manual. Parameters may be default values.)

## 7.2 Tests and Adjustments Procedure

This section describes the instructions for trial operation and adjustment of the AD71. For its trial operation and adjustment as a control system using a PC, refer to the A Series CPU User's Manual.

### 7.2.1 Sequence check

Use the following procedure to check the system.  
Set the key switch on the AD71 front panel to "LOCK." This only changes the present value and allows checking of the positioning functions with the feed pulse output stopped.

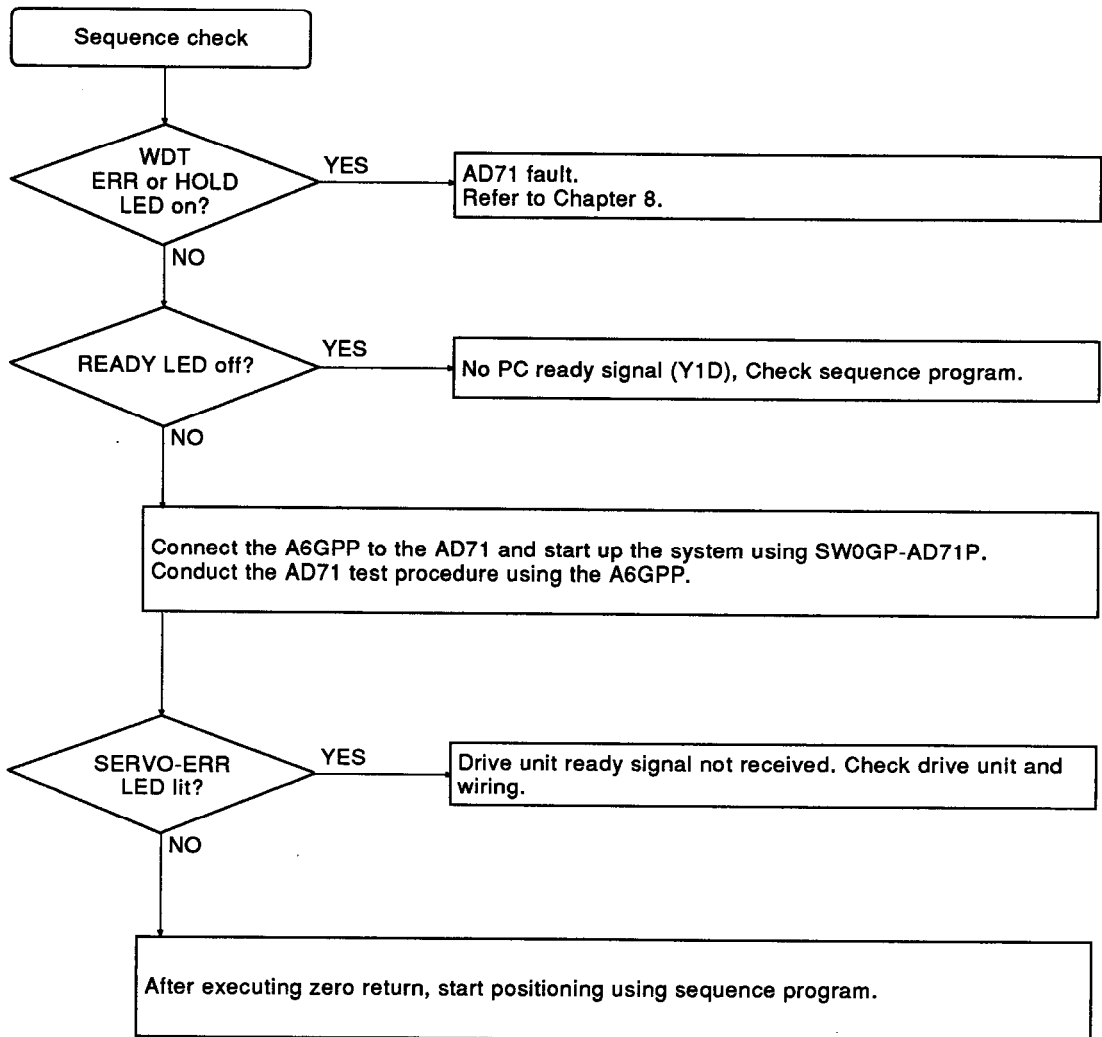

### 7.2.2 Positioning operation check

After completing the check given in Section 7.2.1, turn the key switch on the front of the AD71 to OFF or M.PRO.

Check the operation after setting the parameter speed limit value at slow speed and preparing for an emergency stop if a dangerous state occurs.

The positioning operation should be checked after executing zero return.

The A6GPP (including AD71P) has a handy monitor function and is valid when the operation is faulty. Take corrective action after reading the error code and finding the cause of the error.

**8. TROUBLESHOOTING**

Errors may be detected by:

- 1) the AD71 CPU; or
- 2) the A6GPP during program development and debugging.

This section describes errors detected by the AD71 CPU, for other errors see the SW0GP-AD71P Operating Manual.

**8.1 Errors Detected by AD71**

The AD71 has various error check functions. When an error occurs, an error code is written to address 45 (X axis) and 345 (Y axis) in the buffer memory.

- (1) A new error will overwrite the previous one in the buffer memory. The code is displayed on the lower left hand side of the A6GPP's screen.
- (2) Error code "0" indicates no error.
- (3) Error reset

Errors are reset by writing a "1" to buffer address 201. (See Section 6.3.2 (7))

For resetting of errors using the A6GPP, refer to the SW0GP-AD71P Operating Manual.

- (4) Error detection

XB is the error detection flag. Resetting the error also resets XB.

Error codes are classified as shown in Table 8.1.

**Table 8.1 Error Code Classification**

<b>Error Code</b>	<b>Error Classification</b>	<b>Remarks</b>
1 to 46	Data range error	Refer to Section 8.1.1.
50 to 51	AD71 HOLD error	Refer to Section 8.1.2.
60 to 64	Buffer memory write disable error	Refer to Section 8.1.3.
70 to 79	AD71 start and operation error	Refer to Section 8.1.4.
80 to 81	AD71 BUSY stop error	Refer to Section 8.1.5.
90 to 96,140	Other error	Refer to Section 8.1.6.

8.1.1 Data range errors

Any of the operations shown in Table 8.2 will prompt a data range check by the AD71 as shown below.

Table 8.2 Data Range Check

Data	Operation
Parameters	<ul style="list-style-type: none"> <li>• At power on*</li> <li>• When parameters have been transferred from the A6GPP to the AD71.</li> <li>• When PC ready signal (Y1D) changes from OFF to ON.</li> <li>• When positioning, zero return, jog, or inching has been selected in A6GPP test mode.</li> </ul>
Zero return data	<ul style="list-style-type: none"> <li>• When parameters or zero return data has been transferred from the A6GPP to the AD71.</li> <li>• When PC ready signal (Y1D) changes from OFF to ON.</li> <li>• When positioning, zero return, jog, or inching has been selected in A6GPP test mode.</li> </ul>
Positioning data	<ul style="list-style-type: none"> <li>• At the start of positioning (Refer to the figure in Section 6.3.)</li> </ul>

\* : The power on check will not give an error code or an error detection signal (XB).

A list of error codes is shown in Table 8.3.

**POINT**

When no parameters have been set or any one parameter is erroneous (outside the setting range), all data are controlled as initial values given in Table 3.5, Section 3.5.1. However, the parameter area data remain unchanged from the user settings.

Table 8.3 Data Range Error Codes

Error Code	Data Type	Check Point	Check Range (Errors occur outside the following ranges.)	Remarks
0			Normal	
1	Parameter	Travel per pulse	1 to 100	
2		Speed limit value	1 to 12,000 in mm, inch, or degree (If travel per pulse is "a" (unit/Pulse), speed V range is restricted as given below: $\frac{V(\text{unit/pulse})}{[a(\text{unit/pulse})] \times 60} \leq 200,000 \text{ pulse/s}$ ) 1 to 20,000 in pulse	
3		Jog speed limit value	1 to parameter speed limit value	
4		Starting bias speed	0 to parameter speed limit value	
5		Acceleration and deceleration times	64 to 4,999 (AD71S2/A1SD71-S2: 64 to 50,000)	
6		Backlash	0 to 255 in pulse 0 to 65535 in mm, inch or degree	*3
7		Upper stroke limit	0 to 162,000 in mm 0 to 16,200 in inch or degree 0 to 16,252,928 in pulse	*2
8		Lower stroke limit	0 to upper stroke limit	
9		Error compensation	0 to 100,000 in mm, inch, or degree	
10		Travel distance per manual pulse	1 to 100,000 in mm, inch, or degree 1 to 100 in pulse	
11		Positioning method	00, 01, or 10 in bits b4 and b3	
12		Positioning complete signal duration	0 to 20,000	
20		Zero return data	Zero address	0 to 1,620,000,000 in mm, inch, or degree 0 to 16,252,928 in pulse
21	Zero return speed		Starting bias speed to parameter speed limit. (Not 0)	*1
22	Creep speed		Starting bias speed to parameter zero point return. (Not 0)	
23	Dwell time		0 to 499	
24	Torque limit		10 to 250	

Table 8.3 Data Range Error Codes (continued)

Error Code	Data Type	Check Point	Check Range (Errors occur outside the following ranges.)	Remarks	
30	Positioning data	Positioning speed	Starting bias speed to parameter speed limit. (Not 0)	*1	
31		Positioning address	Within stroke limits		
32		Dwell time	0 to 499		
33		Positioning pattern		00, 01, or 11 in bits 0 and 1 (00 only if start data No. is 400)	
34				Pattern 11 may be used a max. of 9 times consecutively.	
35				Travel for consecutive 11 patterns must be in the same direction.	
36				The addressing method must be the same for consecutive 11 patterns.	
37				Interpolation start setting for both axes must be the same (00 or 01).	
40	Positioning start data	Start number	1 to 400		
41		Pointer	0 to 19		
42		Speed change	Starting bias speed to parameter speed limit (Not 0)	*1	
43		Present value change	0 to 1,620,000,000 in mm, inch, or degree 0 to 16,252,928 in pulse	*2	
44		Jog speed	Starting bias speed to parameter jog speed limit (Not 0)	*1	
45		Start axis	When two axes are to be started at the same time, both must be set for interpolation start (00) or for dual axis start (11).		
46		Start axis	The second axis must not be busy or must be behind the start point when an interpolation start (00) or a dual axis start (11) is called.		

\*1: If the set speed exceeds the parameter speed limit value, positioning is controlled at the parameter speed limit value.

\*2: If the units are mm, inch, or degree and travel per pulse is "a" (unit/pulse), the address S range is restricted as given below:

$$\frac{S(\text{unit})}{a(\text{unit/pulse})} \leq 16,252,928(\text{pulse})$$

\*3: When the travel distance per pulse is set to 1.



**8.1.2 AD71 "HOLD" errors**

The errors shown in Table 8.4 are indicated by the AD71 "HOLD" LED. Errors 50 or 51 indicate a hardware failure.

**Table 8.4 AD71 Hold Error Codes**

Error Code	Check Point	Error Definition	Corrective Action(s)
50	Operation element (8231)	Operation time-out error (hardware fault)	Replace the AD71.
51		Operation error (overflow, underflow, etc.)	
51	AD71	The entire memory has not been cleared.	Clear the entire memory using a peripheral device or the sequence program.
50,51		Operation error due to noise (overflow, underflow, etc.)	Perform either of the following reset operations. <ul style="list-style-type: none"> <li>• Using the reset key switch of the CPU module.</li> <li>• By switching power off and then on.</li> </ul>

In the event of any of the above errors occurring 1) turn off the AD71 ready (X1) and 2) force BUSY processing to stop. The start signal is then not accepted.

**8.1.3 Buffer memory write errors**

Writing data from the sequence program to prohibited buffer addresses or writing when the buffer cannot accept the data prompts the error codes shown in Table 8.5. The sequence program must be checked and corrected.

**Table 8.5 Buffer Memory Write Error Codes**

Error Code	Shared Memory Address	Error Definition
60	39,339	Pointer value is not 0 though 20th point has been reached. Data has been written to pointer address while BUSY.
61	40,340	"Speed change" during interpolation.
62	41,42,341,342	"Present value change" while BUSY.
63	7872 to 7928	Data written from PC while Y1D is on.
64	Monitoring present value area Speed area	Data written from PC to a write prohibit address.

## 8.1.4 AD71 start and operation errors

The following errors are detected when AD71 cannot start operations after receiving a PC CPU command due to AD71 internal condition errors or AD71 operating errors. Error codes are shown in Table 8.6 below.

**Table 8.6 AD71 Start and Operation Error Codes**

Error Code	Cause	Corrective Action(s)
70	READY signal is OFF at the start	Set the drive unit READY.
71	External stop signals (6A and 8A) are ON at the start.	Turn OFF the stop signals (6A and 8A).
72	The AD71 ready signal (X1) and PC CPU ready signal (Y1D) are OFF at the start.	Turn ON the PC CPU power and set the PC CPU to RUN. Check the hardware.
73	The relevant axis is BUSY at the start.	Do not start when BUSY.
74	The relevant axis positioning complete signal is ON at the start.	Restart after turning OFF the start signal.
75	The M code ON signal is ON at the start.	Turn OFF the "M code ON" signal using the "M code OFF" signal.
76	<ul style="list-style-type: none"> <li>The stop signals (Y25, Y26) are ON at the start.</li> <li>Inputting the BREAK key from an A6GPP stops operations.</li> </ul>	<ul style="list-style-type: none"> <li>Turn OFF the stop signals (Y25, Y26).</li> <li>Release the stop processing from the A6GPP or AD71TU.</li> </ul>
77	Zero return is repeated more than twice consecutively.	Zero return cannot be repeated. (1) Position to a point before the near-zero point dog using JOG operation, and then perform another zero return operation. (2) Operate the system briefly in the positioning mode, and then perform a zero return operation.
78	The zero return complete signal is ON when zero return is started.	Zero return has been already completed. Transfer positioning or the jog operation.
79	Outside the range from 0 to 16252928 pulses.	<ul style="list-style-type: none"> <li>Return inside the stroke limit range using jog.</li> <li>Perform zero return.</li> <li>Change the present value.</li> </ul>

**Note 1:** Start includes;

- Zero return start
- Jog operation
- Manual pulse

**Note 2:** For interpolation starts, error codes are always given for both axes even if one axis has an error.

**8.1.5 AD71 positioning start errors during BUSY**

The following errors are detected when the drive unit ready signal is turned OFF while AD71 is BUSY or when positioning is stopped during zero return.

**Table 8.7 BUSY Error Codes**

Error Code	Cause	Corrective Action(s)
80	The READY signal is OFF during BUSY.	Check the drive unit and turn ON the ready signal.
81	Zero return is stopped.	Zero return is not allowed more than twice consecutively. If necessary, return to the position before near-point dog using a jog operation or positioning by specifying the data number, and restart zero return.

**8.1.6 Other errors**

**(1) Errors exclusive to AD71S2 and A1S-D71-S2**

Error Code	Data Type	Check Point	Corrective Action(s)
90	Parameter	Positioning mode	Data is set outside the range from 0 to 2.
91		Emergency deceleration time	Data is set outside the range from 64 to 50000 (msec).
92	Start processing error	_____	Interpolation is started in the speed/positioning control switching mode.
93		Restart area	In the switching mode: • Restarted after a stop during speed control. • Restart after completing positioning.
94	Start data error	Start number	The restart number is different from executing number.
95		Travel distance change area	Data is set outside the range from 0 to the stroke upper limit.
96	Buffer memory write-protected	Setting travel distance area	Data is written from the PC CPU to a write-protected area.

**(2) Errors exclusive to AD71S7 and A1S-D71-S7**

Error Code	Data Type	Check Point	Corrective Action(s)
140	Data at positioning start	Manual pulse output speed	Data is set outside the range of 1 pulse to 2000 pulses.

**(3) "AD71 bus error"**

Besides an AD71 fault, the factor responsible for this error may be continuous access to the AD71 buffer memory in large amount from the sequence program. In this case, refer to Section 8.2 and check.

**REMARK**

The "AD71 bus error" can be confirmed only when AD71P or AD71TU is used.

8.2 Troubleshooting

8.2.1 General troubleshooting

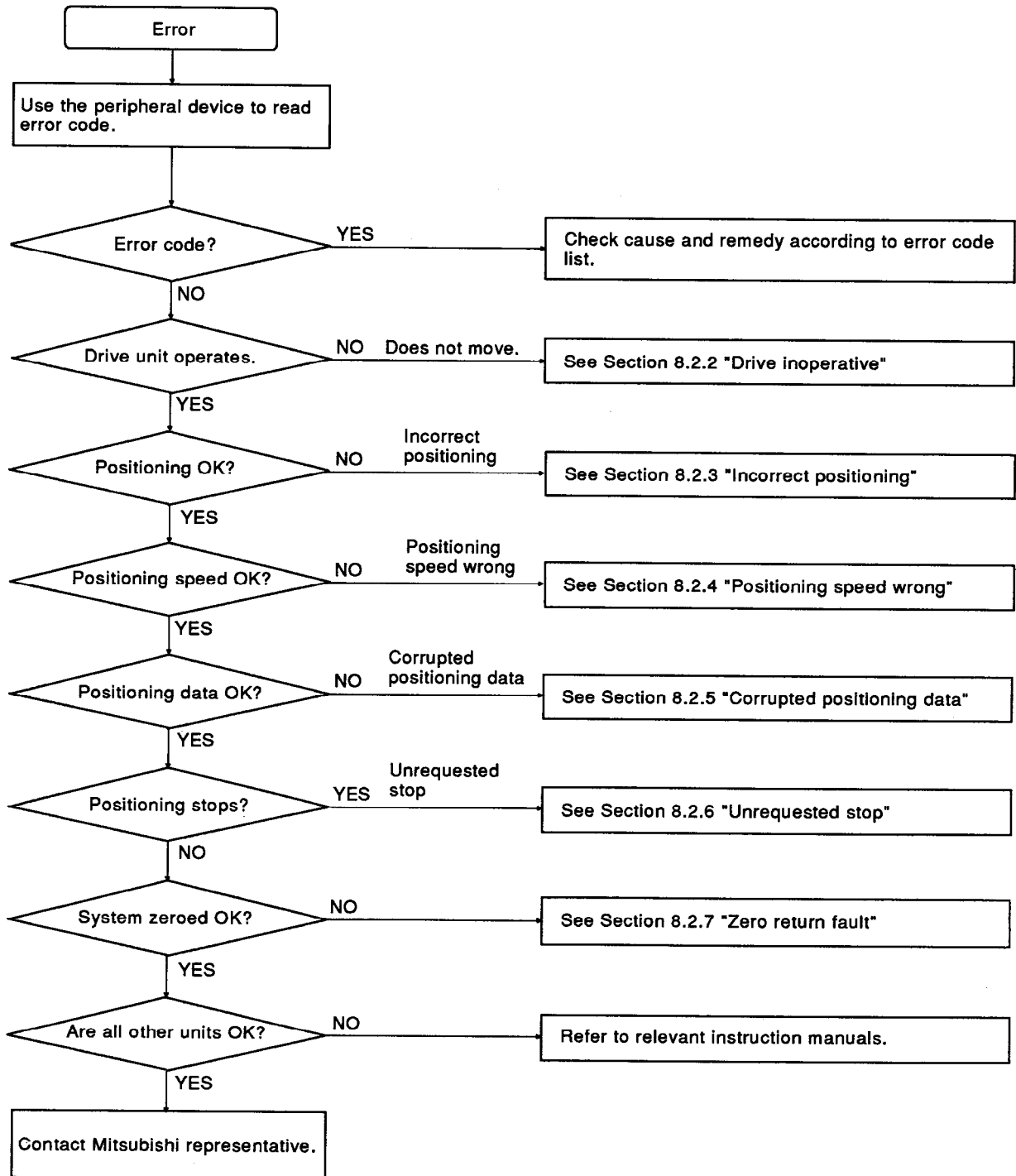

8.2.2 Drive inoperative

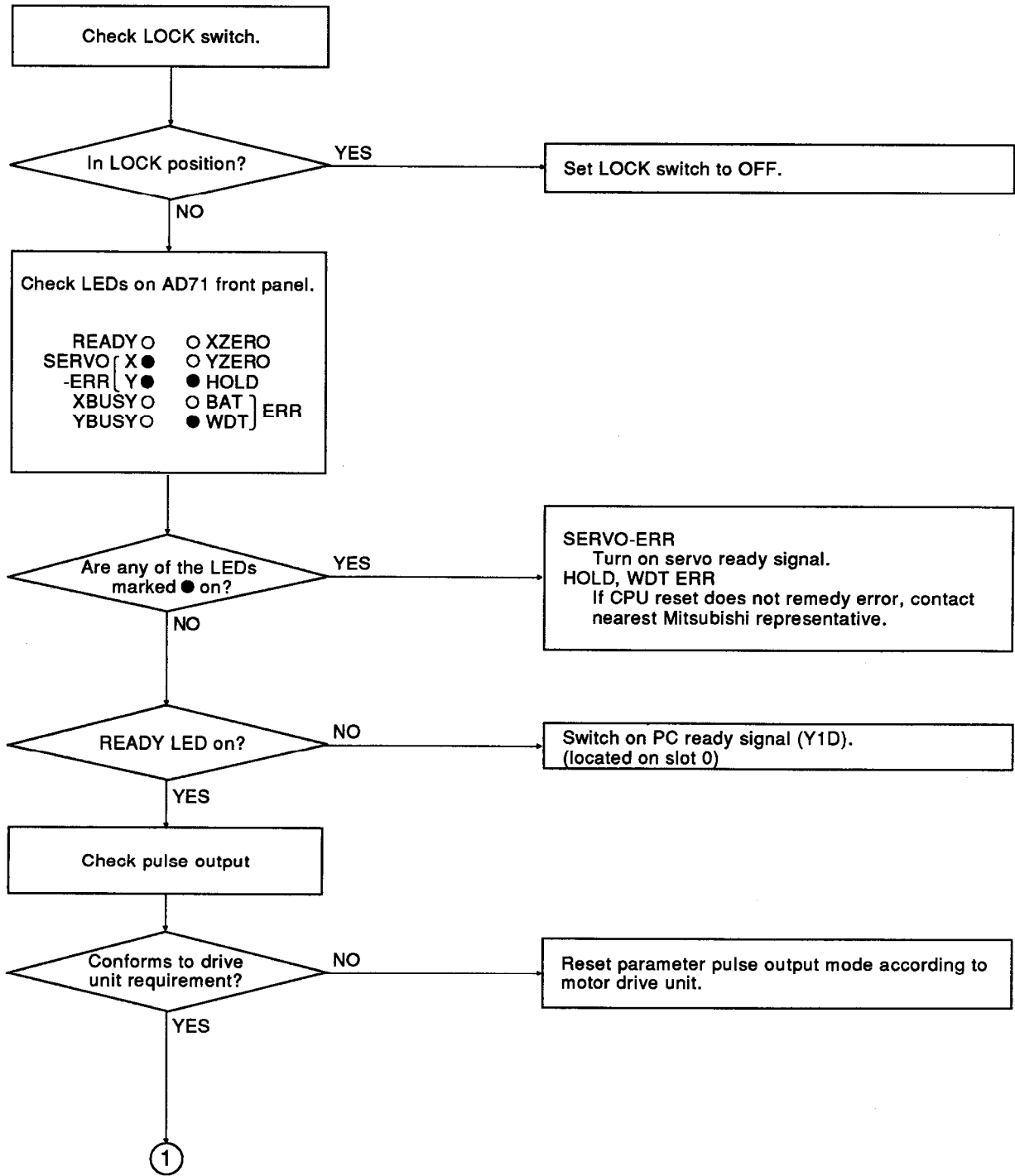

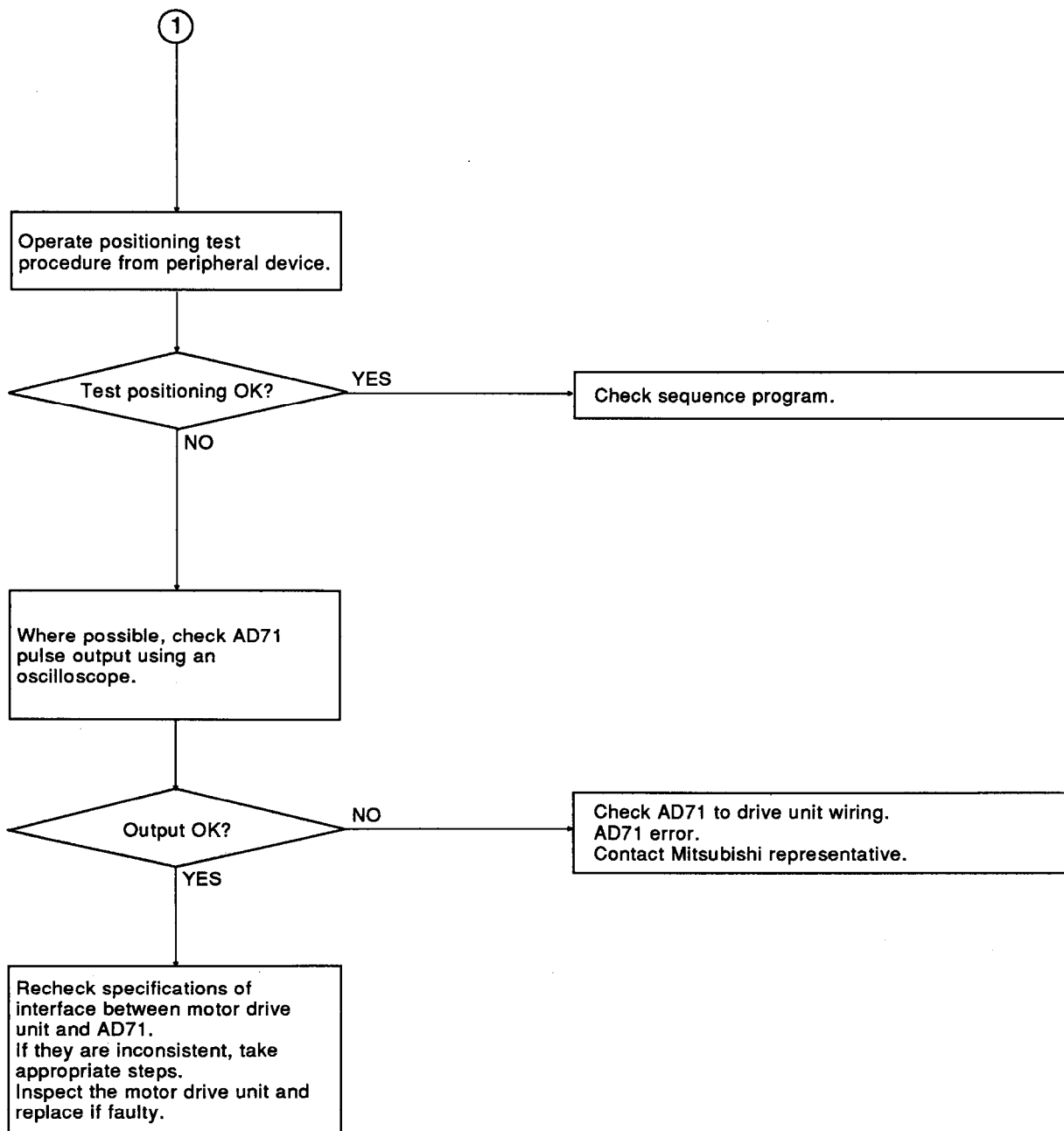

8.2.3 Incorrect positioning

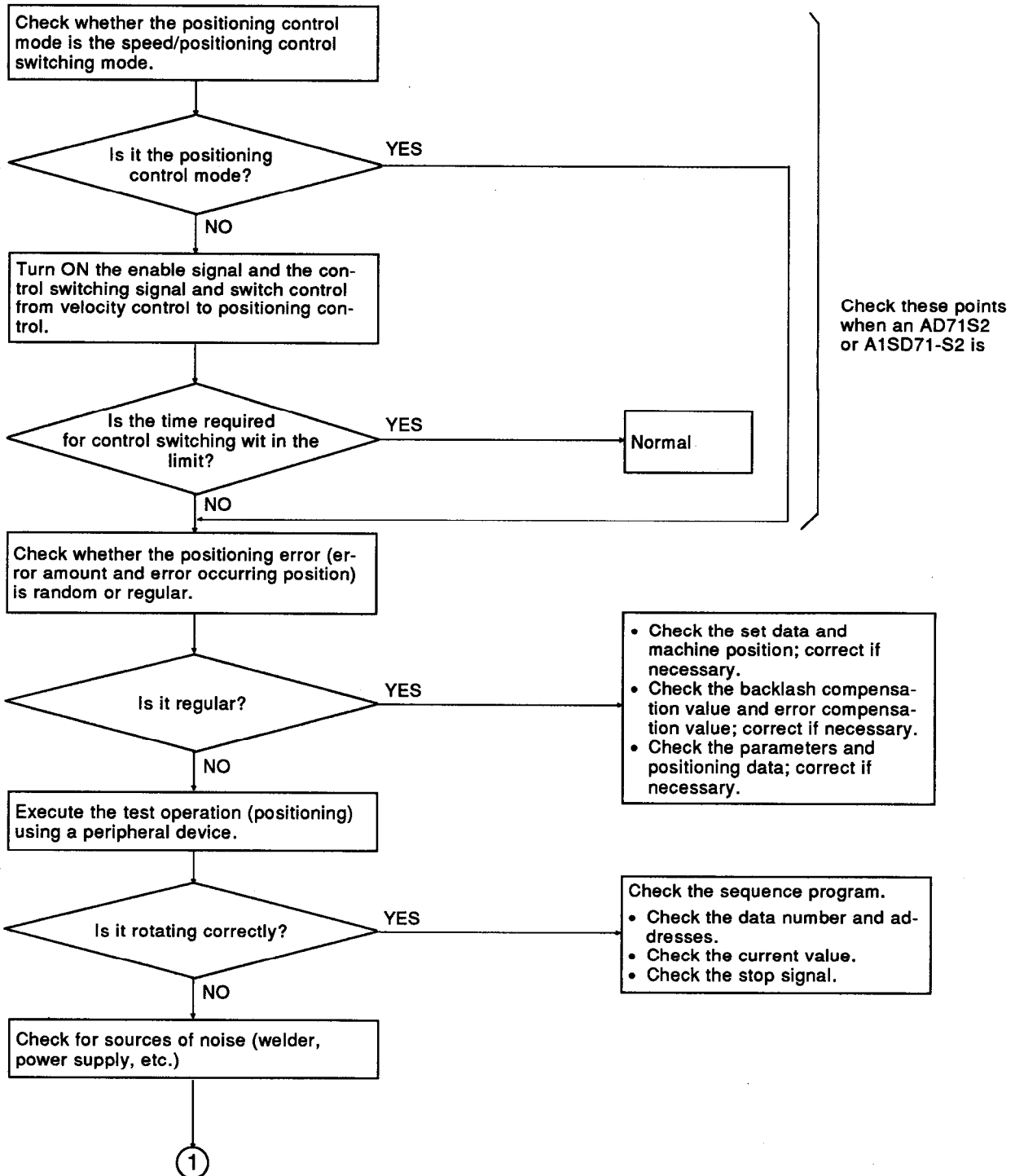

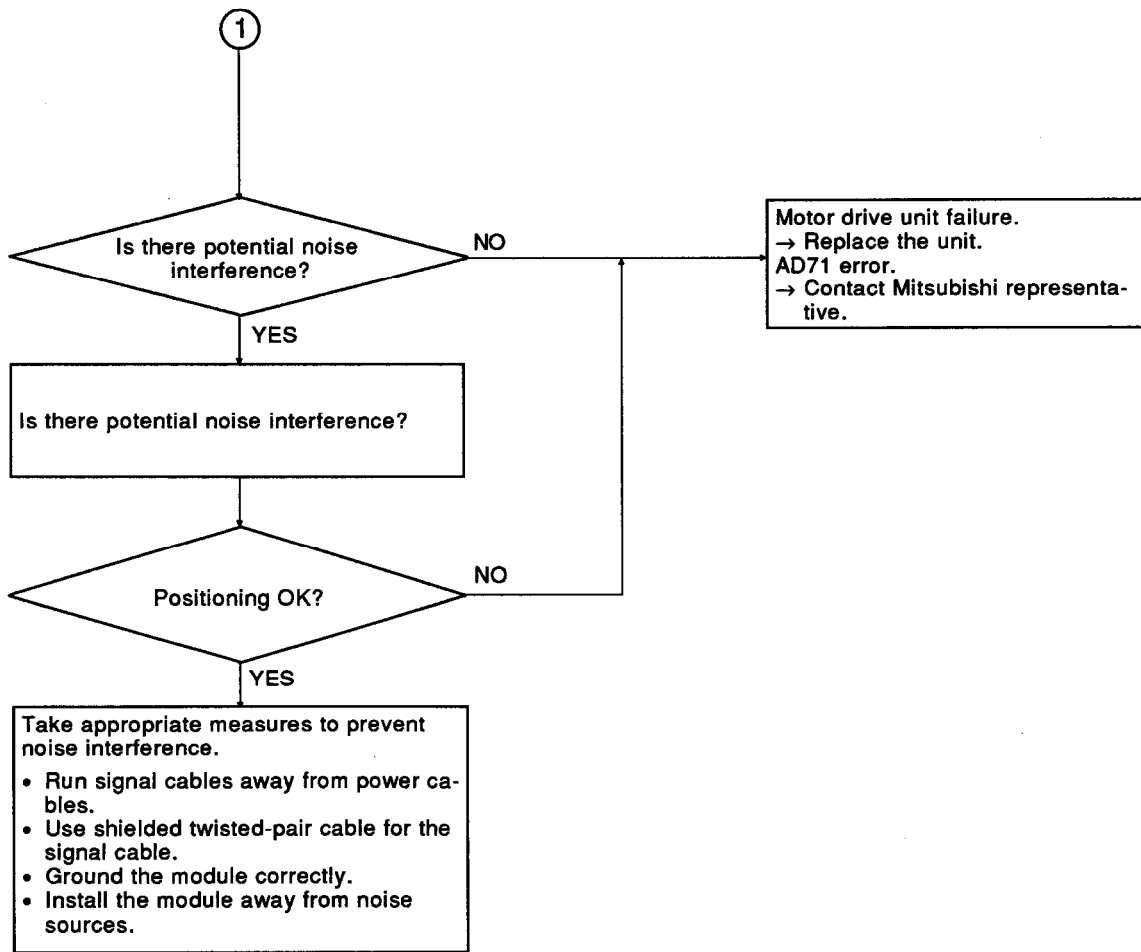



## 8.2.4 Positioning speed wrong

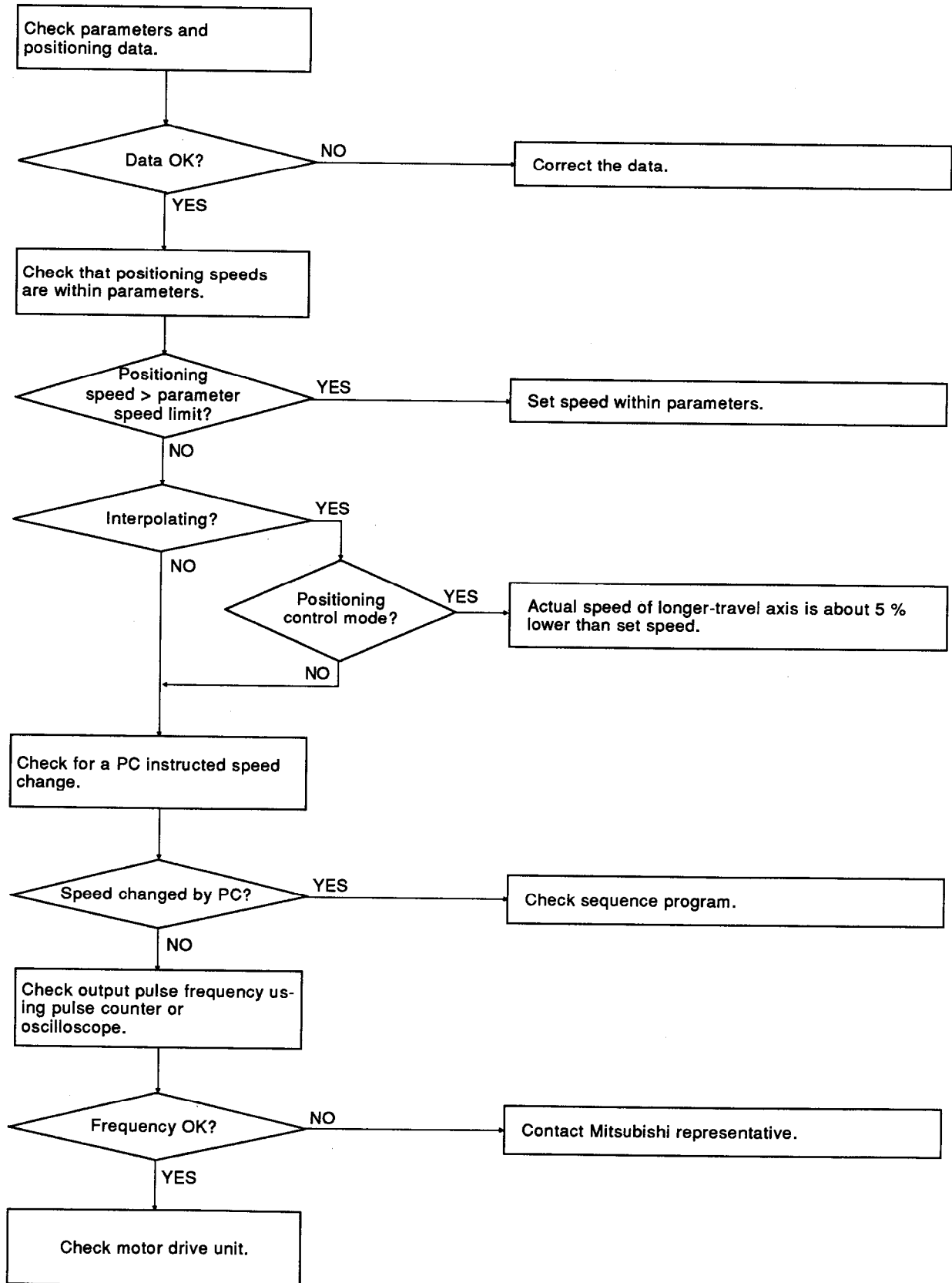

8.2.5 Corrupted positioning data

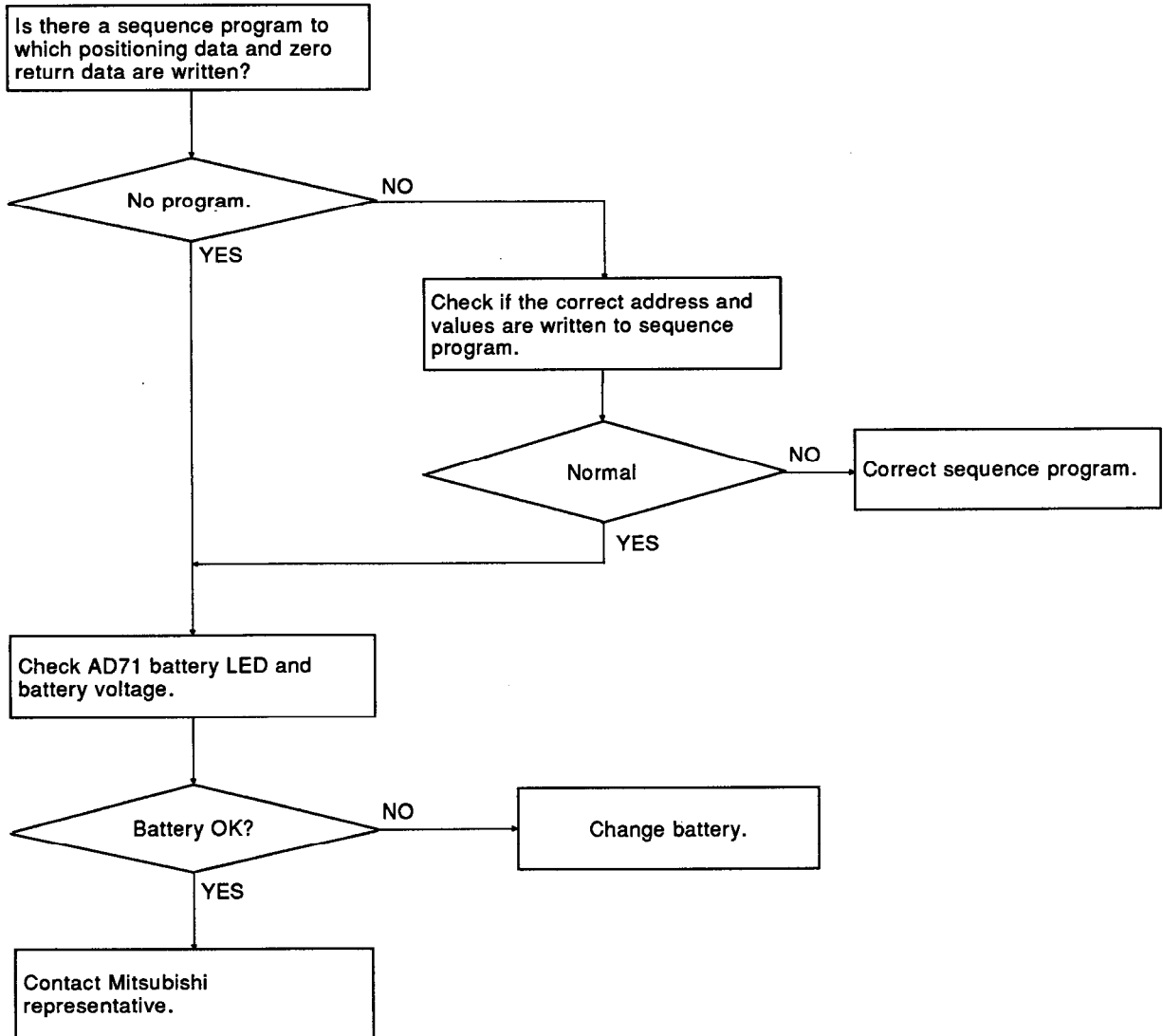

## 8.2.6 Unrequested stop

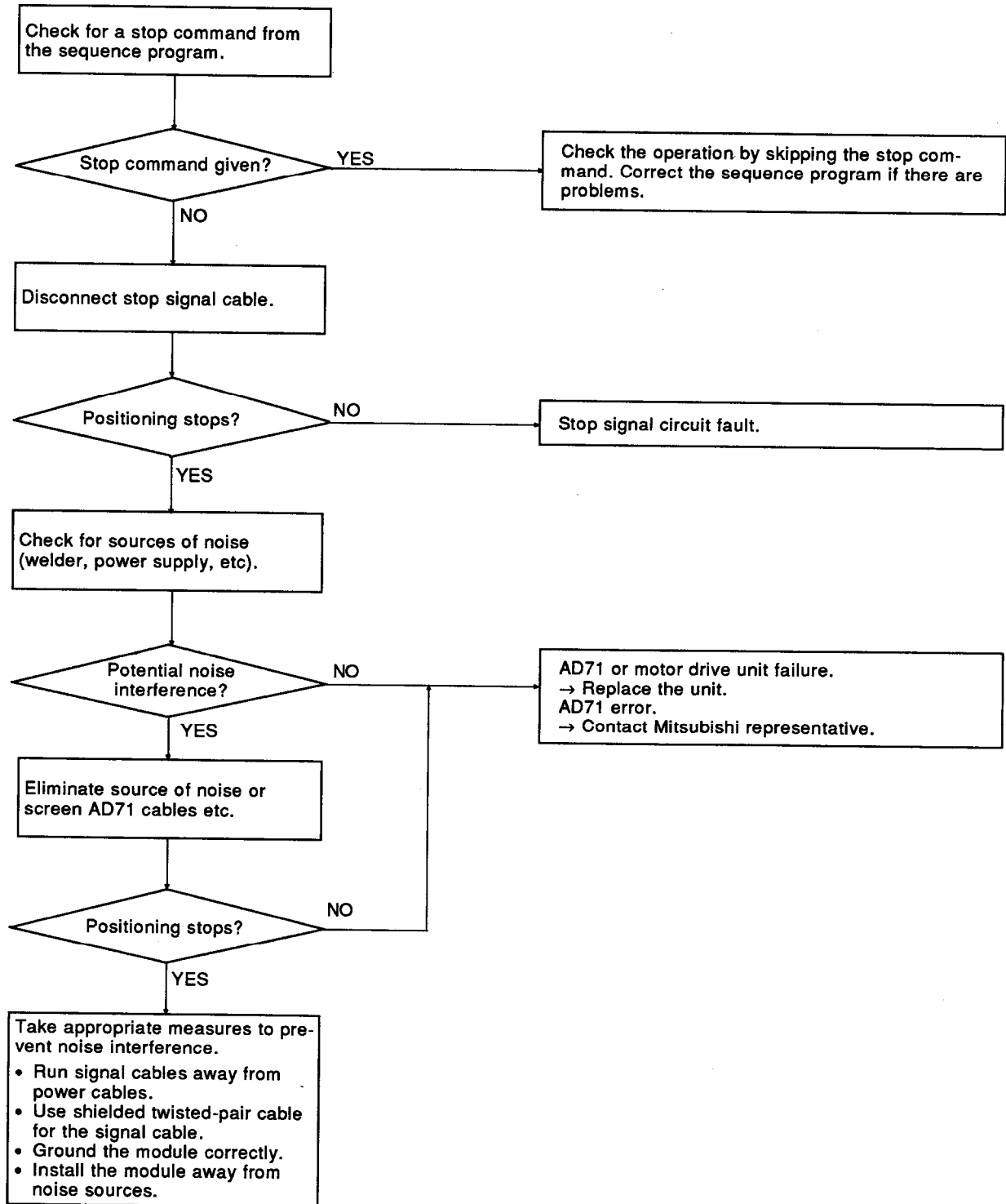

8.2.7 Zero return fault

(1) Partial zero return

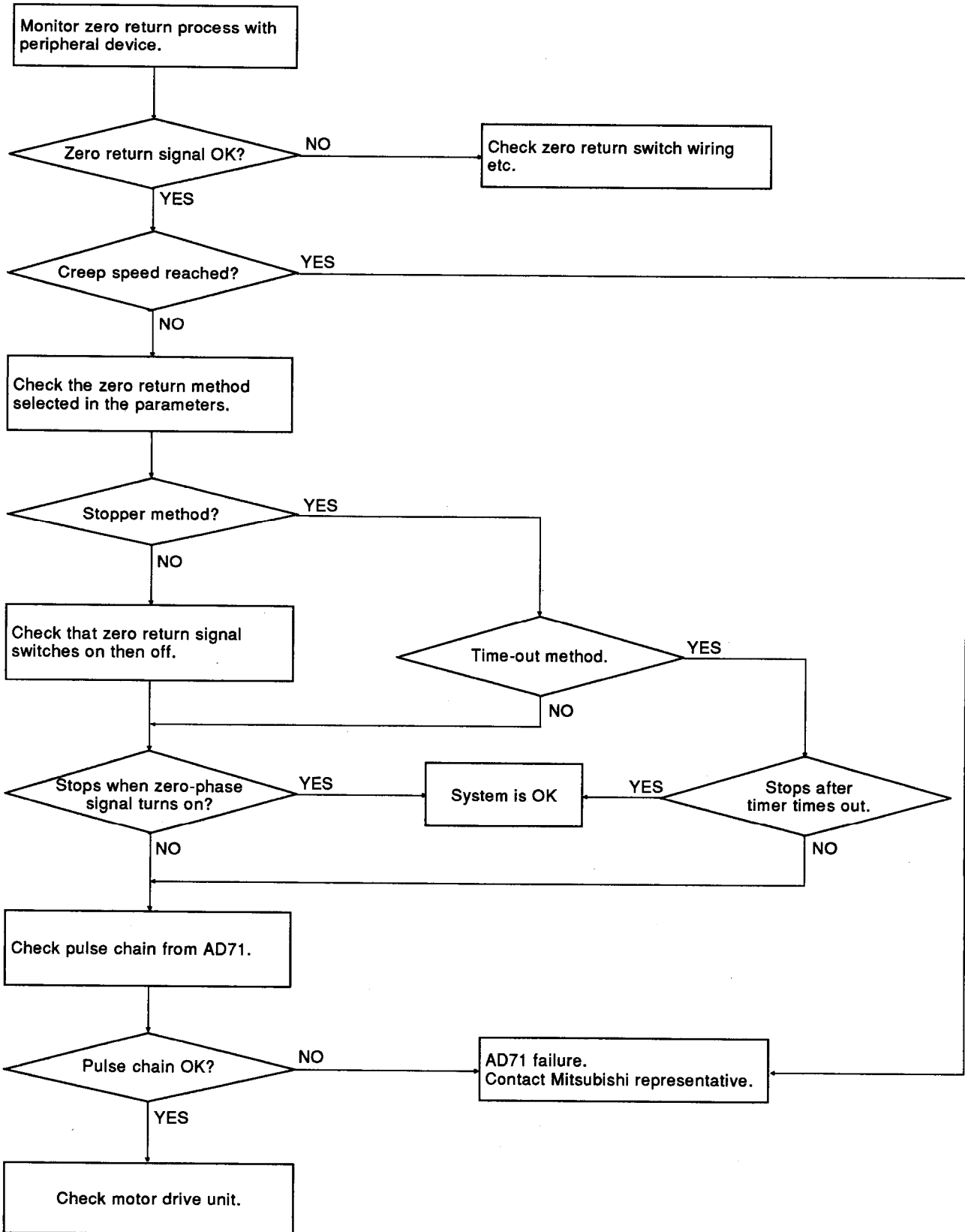

(2) Zero point position has shifted (using zero-phase signal)

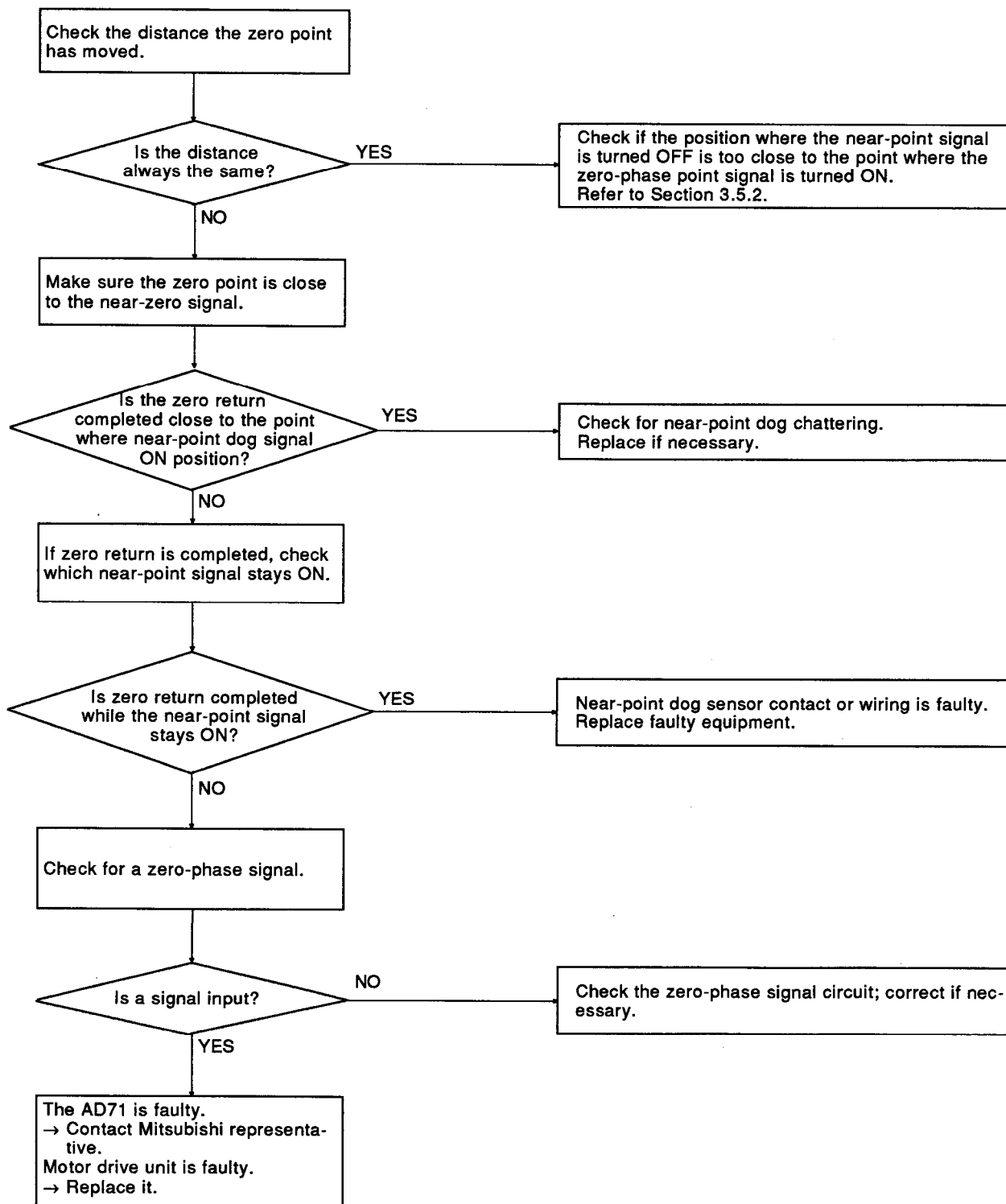

**Note :** When using the stopper method, make sure that the stop signal is input or timer setting is correct. If so, the AD71 or motor drive unit is faulty. Replace the faulty AD71 or motor drive unit.

### 9. MAINTENANCE

This section describes how to maintain the AD71 (unit storage and battery replacement).

For other modules (i.e., the power module, PC CPU module, I/O module, special modules, etc.), refer to the appropriate User's Manual.

#### 9.1 Unit Storage

The AD71 should be stored in the following environments:

- (1) Ambient temperature 0 to 75 °C.
- (2) Ambient humidity 10 to 90 % RH.
- (3) No condensation (e.g. due to sudden temperature changes).
- (4) No direct exposure to sunlight.
- (5) Free from excessive amounts of conductive powder such as dust, iron filings, oil mist, salt, or organic solvent.

A two hour "warming up" period should be allowed if the AD71 has not been powered up for over 12 months. (This is to allow the electrolyte in electrolytic capacitor to stabilize.) The battery should be replaced every 10 months if the unit is not powered up to maintain buffer memory data. (If the AD71 has not been used for 10 months or more, the data in the AD71 could be lost. In this case, it is necessary to check the set data.)

## 9.2 Battery Change

This section explains when and how to change the battery.

## 9.2.1 Battery change frequency

When the data backup battery voltage drops, the LED on the AD71 front panel is lit and an input signal (battery error) to the PC CPU is enabled. The battery is live for about one month more and, if it is not replaced, data will then be lost or corrupted.

Guide for preventive maintenance

- 1) The battery should be replaced every 4 to 5 years if it is only used for memory back up for a maximum of 300 days in that period.
- 2) Battery changing frequency for memory backup duty exceeding 300 days can be calculated as follows.

**Example**

Assume that there are five operation days (10-hour operation and 14-hour power-off during a day) and two power-off days in a week. Under these conditions, power-off period during one week is:

$$\begin{array}{l} 14 \text{ (hours)} \times 5 \text{ (days)} = 70 \text{ hours} \\ 24 \text{ (hours)} \times 2 \text{ (days)} = 48 \text{ hours} \end{array} \left. \vphantom{\begin{array}{l} 14 \\ 24 \end{array}} \right\} \begin{array}{l} \text{Total power supply off time for} \\ \text{one week} \end{array}$$

$$7200 \text{ (hours)} / (70 + 48) \text{ (hours)} = 61 \text{ (weeks)}$$

$$61 \text{ (weeks)} \times 7 \text{ (days)} = 427 \text{ (days)}$$

Regarding one month as 30 days,

$$427 \text{ (days)} / 30 \text{ (days)} = 14.2 \text{ months}$$

Hence,

it is necessary to change the battery every 14 months.

**REMARK**

The same battery is used for all MELSEC-A series modules.

The battery can be stored for five years. The battery is guaranteed to work for 300 days in total. The following battery is used. When replacing the battery, order from a Mitsubishi representative.

Product : Lithium battery

Model : A6BAT (with 3.6 V lead wire)

Precautions when handling the battery

- (1) Do not short circuit the battery.
- (2) Do not take the battery apart.
- (3) Keep the battery away from fire.
- (4) Do not heat the battery.
- (5) Do not solder the electric poles.
- (6) Do not measure the voltage using a tester. Otherwise, the capacity will be greatly lowered.

9.2.2 Battery replacement procedure

Fig. 9.1 shows how to replace the battery.

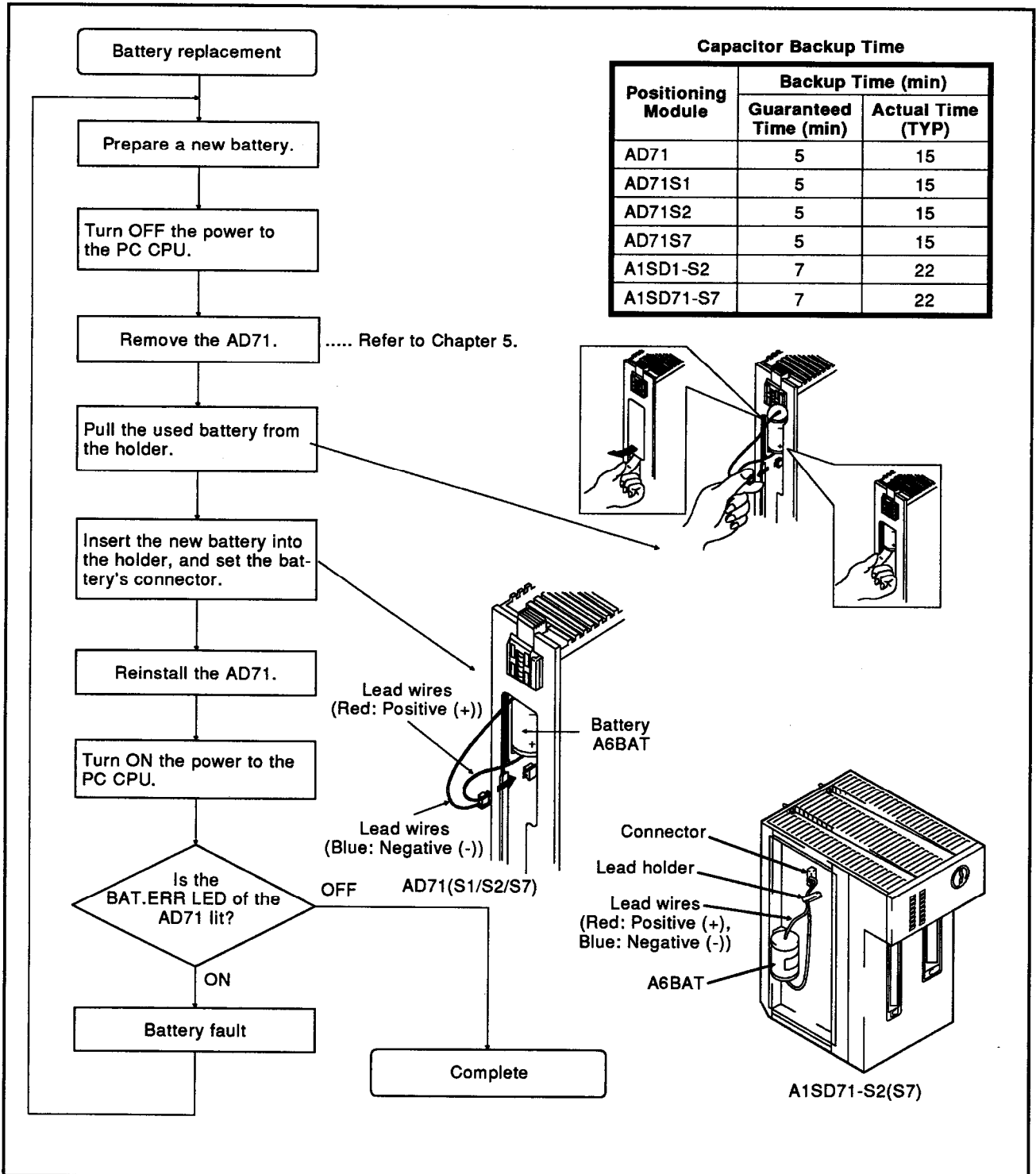

Fig. 9.1 Battery Replacement Procedure



**IMPORTANT**

The components on the printed circuit board may be damaged by static electricity. When handling the printed circuit board:

- 1) Ground all tools, work bench, etc.
- 2) Do not touch the conductive areas or electrical components.

APPENDICES

APPENDIX 1 FORMAT SHEETS

1.1 MELSEC-A Positioning unit

X AXIS ADDRESS

mm, inch, degree, PLS

Y AXIS ADDRESS

mm  
inch  
degree  
PLS

1.2 Format Sheets

(1) Parameters

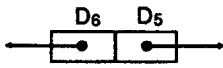
Item	Initial Value	X Axis	Y Axis	mm		inch		degree		pulse	
				Setting Range	Unit	Setting Range	Unit	Setting Range	Unit	Setting Range	Unit
1 Unit setting	3			0	-	1	-	2	-	3	-
2 Travel per pulse	Set value			1 to 100	$\times 10^{-1}$ $\mu\text{m}/\text{pulse}$	1 to 100	$\times 10^{-5}$ inch/pulse	1 to 100	$\times 10^{-5}$ deg/pulse	-	
3 Speed limit value	20,000			1 to 12,000	$\times 10$ mm/min	1 to 12,000	$\times 1$ inch/min	1 to 12,000	$\times 1$ deg/min	1 to 20,000	$\times 10$ pulse/s
4 Jog speed limit value	2,000			1 to 12,000	$\times 10$ mm/min	1 to 12,000	$\times 1$ inch/min	1 to 12,000	$\times 1$ deg/min	1 to 2,000	$\times 10$ pulse/s
5 Starting bias speed	0			1 to 12,000	$\times 10$ mm/min	1 to 12,000	$\times 1$ inch/min	1 to 12,000	$\times 1$ deg/min	1 to 20,000	$\times 10$ pulse/s
6 Backlash	0			0 to 65,535	$\times 10^{-1}$ $\mu\text{m}$	0 to 65,535	$\times 10^{-5}$ inch	0 to 65,535	$\times 10^{-5}$ deg	0 to 255	pulse
7 Upper stroke limit	16,252,928			0 to 162,000	mm	0 to 16,200	inch	0 to 16,200	deg	0 to 16,252,928	pulse
8 Lower stroke limit	0			0 to 162,000	mm	0 to 16,200	inch	0 to 16,200	deg	0 to 16,252,928	pulse
9 Error compensation	0			$\pm 0$ to 100,000 (per 1 m)	$\times 10^{-1}$ $\mu\text{m}$	$\pm 0$ to 100,000 (per 100 inch)	$\times 10^{-5}$ inch	$\pm 0$ to 100,000 (per 100 deg)	$\times 10^{-5}$ deg	-	
10 Travel per manual pulse during inching	1			0 to 100,000	$\times 10^{-1}$ $\mu\text{m}$	0 to 100,000	$\times 10^{-5}$ inch	0 to 100,000	$\times 10^{-5}$ deg	0 to 100	pulse
11 Acceleration and deceleration times	1,000			64 to 50,000 ms							
12 Positioning complete signal output time	300			0 to 20,000 ms							
13 Pulse output mode	Set value			0 : PLS + SIGN 1 : forward pulse, reverse pulse							
14 Rotating direction setting	Set value			0 : present value increase with forward pulse output 1 : present value increase with reverse pulse output							
15 Absolute/incremental setting	0			0 : absolute 1 : incremental 2 : absolute/incremental combined							
16 M code ON/OFF timing	Set value			0 : WITH mode 1 : AFTER mode				0 : not used 1 : used			
17 Deceleration time for emergency stop*	9,000			64 to 50,000 ms							
18 Positioning mode*	0 = positioning control			0 : Positioning control mode 1 : Speed/positioning control switching mode 2 : Speed control mode							

\*: Should be set when an AD71S2 or A1SD71-S2 is used.

(2) Zero return data

Item	X Axis	Y Axis	mm		inch		degree		pulse		
			Setting Range	Unit	Setting Range	Unit	Setting Range	Unit	Setting Range	Unit	
1	Zero return direction		0 : forward direction (address increase) 1 : reverse direction (address decrease)								
2	Zero return method		See below.								
3	Zero return address		0 to 1,620,000,000	$\times 10^{-1}$ $\mu\text{m}$	0 to 1,620,000,000	$\times 10^{-5}$ inch	0 to 1,620,000,000	$\times 10^{-5}$ deg	0 to 16,252,928	pulse	
4	Zero return speed		1 to 12,000	$\times 10$ mm/min	1 to 12,000	$\times 1$ inch/min	1 to 12,000	$\times 1$ deg/min	1 to 20,000	$\times 10$ pulse/s	
5	Creep speed		1 to 12000	$\times 10$ mm/min	1 to 12,000	$\times 1$ inch/min	1 to 12,000	$\times 1$ deg/min	1 to 20,000	$\times 10$ pulse/s	
6	Dwell		0 to 499 $\times 10$ ms								
7	Trque limit		10 to 250 %								

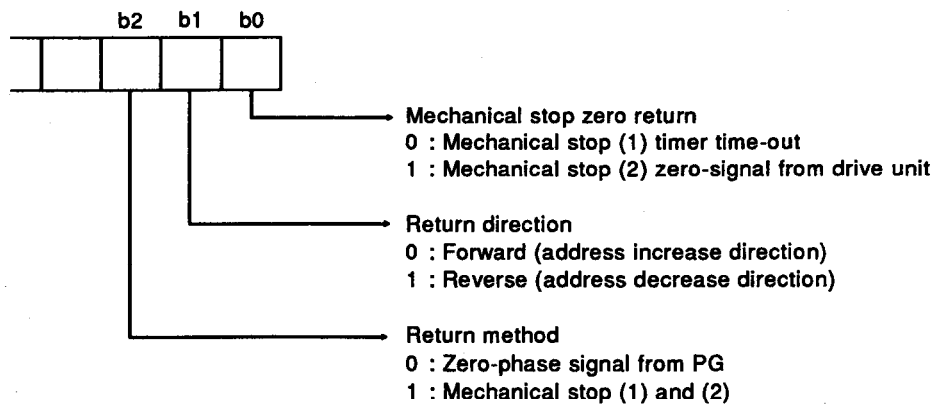

1.3 Positioning Data (Data No. to )

X AXIS						
Data No.	Pattern	Abs./ Inc.	Direction	Speed	Address	M code
1						
2						
3						
4						
5						
6						
7						
8						
9						
0						
1						
2						
3						
4						
5						
6						
7						
8						
9						
0						
1						
2						
3						
4						
5						
6						
7						
8						
9						
0						

00 :END 0 :Abs. For Inc. 0 to255  
 01 :Continue 1 :Inc. 0 :Address increase direction 0 :Without M code  
 11 :Change 1 :Address decrease direction 1 to 19 :With comment

Y AXIS						
Data No.	Pattern	Abs./ Inc.	Direction	Speed	Address	M code
1						
2						
3						
4						
5						
6						
7						
8						
9						
0						
1						
2						
3						
4						
5						
6						
7						
8						
9						
0						
1						
2						
3						
4						
5						
6						
7						
8						
9						
0						

00 :END 0 :Abs. For Inc. 0 to255  
 01 :Continue 1 :Inc. 0 :Address increase direction 0 :Without M code  
 11 :Change 1 :Address decrease direction 1 to 19 :With comment

**1.4 M Code Comments**

<b>M CODE</b>	<b>X AXIS</b>	<b>M CODE</b>	<b>Y AXIS</b>
1		1	
2		2	
3		3	
4		4	
5		5	
6		6	
7		7	
8		8	
9		9	
10		10	
11		11	
12		12	
13		13	
14		14	
15		15	
16		16	
17		17	
18		18	
19		19	

Maximum 16 characters per comment

APPENDIX 2 SIGNAL TIMING FROM THE AD71

2.1 Output Signal Timing

This section gives the output signal timing chart for positioning, operating in the speed control module, and zero return.

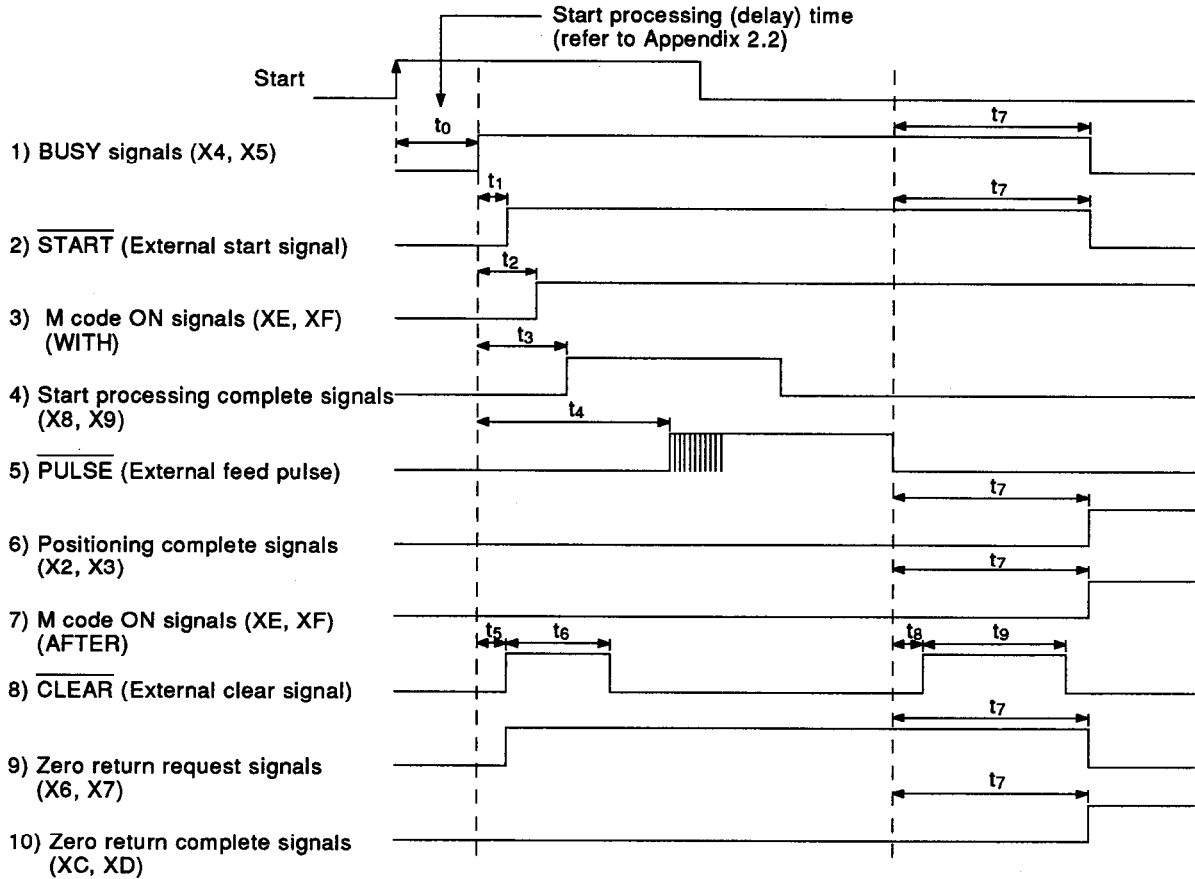

	Positioning in the Positioning Control Mode			Positioning in the Switching Mode		Positioning in the Speed Mode		Zero Return	
	X axis	Y axis	Interpolation	X axis	Y axis	X axis	Y axis	X axis	Y axis
t <sub>1</sub> (msec)	0.2	0.2	0.3	0.2	0.2	0.3	0.3	49.1	49.1
t <sub>2</sub> (msec)	0.3	0.3	0.6	0.3	0.3	—	—	—	—
t <sub>3</sub> (msec)	0.5	0.5	0.8	0.5	0.5	0.5	0.5	0.4	0.4
t <sub>4</sub> (msec)	18.4	18.4	18.4	18.4	18.4	18.4	18.4	58.3	58.3
t <sub>5</sub> (msec)	—	—	—	—	—	—	—	0.1	0.1
t <sub>6</sub> (msec)	—	—	—	—	—	—	—	49.5	49.5
t <sub>7</sub> (msec)	1.4	1.4	1.4	1.8	1.8	27.5	27.5	17.7	17.7
t <sub>8</sub> (msec)	—	—	—	—	—	—	—	0.7	0.7
t <sub>9</sub> (msec)	—	—	—	—	—	—	—	16.5	16.5

Note 1: Indicates the timing in the case of pattern (00) and pointer (0) for positioning in the positioning control mode.

Note 2: The timing when executing the zero return is given in 8) to 10) above.

Note 3: The dwell time when executing positioning is measured as "0".

## 2.2 Start Delay Time

This section explains the time ( $t_0$ ) required after turning ON the start signal until the AD71 BUSY signals (X4 and X5) go ON.

The following chart gives the timings for the start signal and BUSY signals.

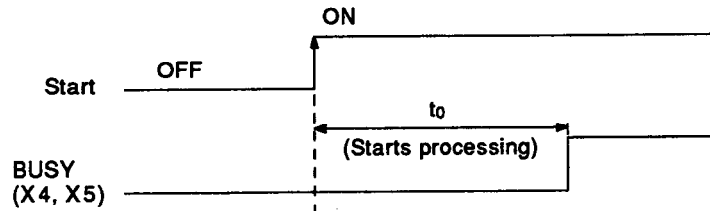

### (1) Variations in start processing times

Start processing times until a BUSY signal is turned on vary according to the following conditions:

- 1) Execution of the FROM/TO instruction during start processing
  - If the FROM/TO instruction is executed, a delay up to several seconds could occur because the FROM/TO instruction takes priority.
  - If a FROM/TO instruction is not executed, no delay will occur.
- 2) Operating state of the other axis
  - If start processing is executed during the operation of the other axis, a delay of less than 100 ms will occur.
  - If the other axis is not in use, no delay will occur.
- 3) Intervention by a peripheral device during start processing
  - If a peripheral device intervenes, a delay of several ms will occur.
  - When no peripheral device is connected, no delay will occur.
- 4) The number of speed change points in the positioning pattern in (11)
  - As the number of speed change points in the positioning pattern in (11) increases, the delay is increased. (Approx. 10 ms per point)

### (2) Start processing time ( $t_0$ )

Table 1.1 gives the measurement processing time under the following conditions with no delay resulting from the above items:

- 1) A FROM/TO instruction is not executed during the start processing.
- 2) The other axis is not in use.
- 3) No peripheral device intervenes.



Table 1.1 Start Processing Times

	Operating Mode		Min. Value of $t_0$ (ms) *1	Max. Value of $t_0$ (ms) *2
1	Zero return start		$5.5 \pm 5$	$14 \pm 12$
2	JOG start		$4.5 \pm 5$	$33 \pm 12$
3	Positioning control mode	Independent positioning start	$15 \pm 5$	$58 \pm 12$
		Interpolation positioning start	$61 \pm 5$	$94 \pm 12$
4	Speed/positioning control switching mode	Independent positioning start	$28 \pm 5$	$61 \pm 12$
5	Speed control mode	Independent operation start	$12 \pm 5$	$45 \pm 12$
		Interpolation operation start	$28 \pm 5$	$61 \pm 12$
6	Positioning pattern (11) Speed change positioning continuation	Number of speed change points: 4	$61 \pm 5$	$94 \pm 12$

\*1:  $t_0$  becomes minimum when the X or Y axis starts under any of the following conditions:

1. After zero return has been completed.
2. After positioning has been completed.
3. After a present value has been changed.

\*2:  $t_0$  becomes maximum when X or Y axis starts under any of the following conditions:

1. After zero return has been canceled.
2. After positioning has been canceled.
3. After an operation in the speed control mode.
4. After a JOG operation has been stopped.

Note (1): Feed pulses are output after the BUSY signals (X4 and X5) have been turned ON and  $t_0$  (ms) has passed (refer to Appendix 2.1).

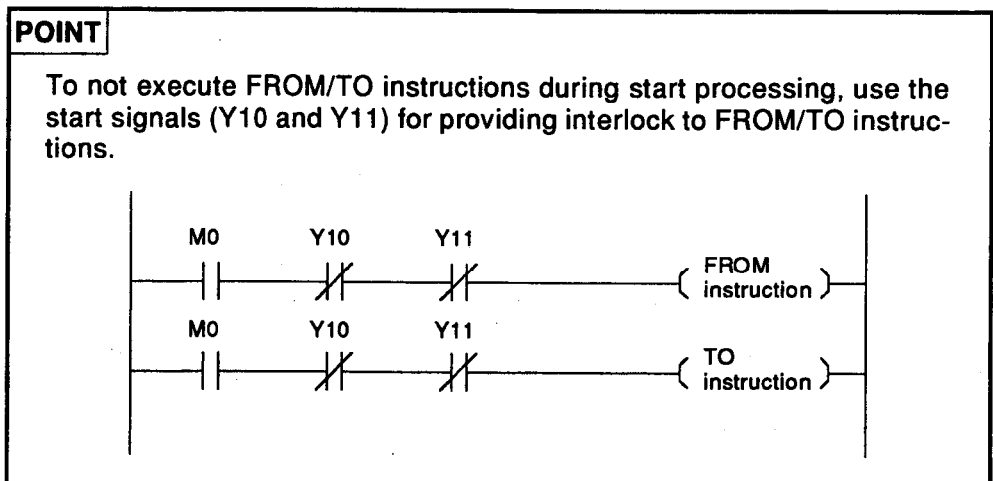

2.3 AD71 Processing Times

The processing times for each pattern operation are as follows:

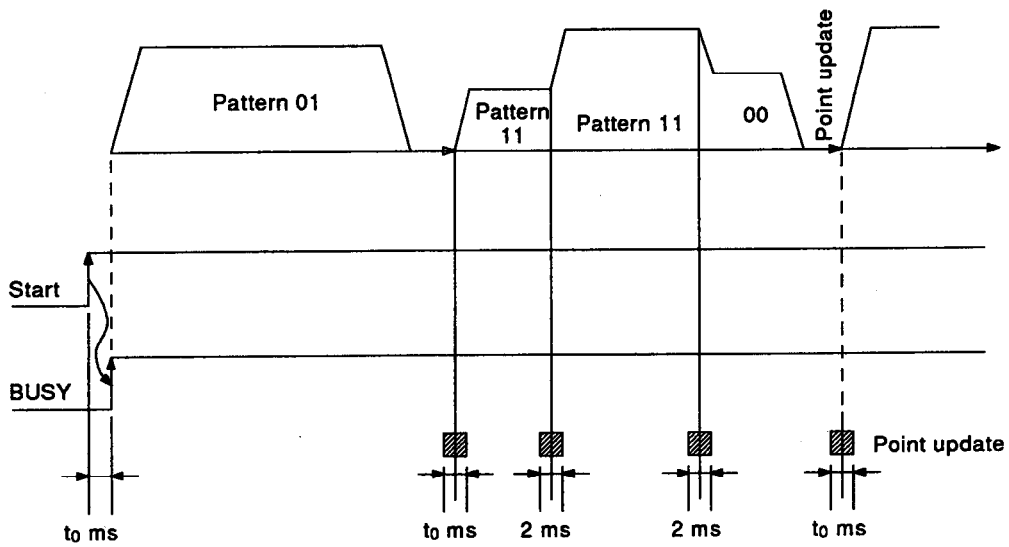

The above times do not include the processing time of the PC CPU, representing the estimated processing time of the AD71.

APPENDIX 3 CONNECTION WITH SERVO MOTORS

There are several drive unit models and motors that can be used with the AD71. Examples of connections as of July 1994 are given. These examples shall be used only for reference because the driver's specifications are subject to change. Other drive units than described here can also be used.

[CAUTION]

- (1) The AD71 output is a sink output pulse chain.  
The drive unit should be sink input.
- (2) For use with source input drive units, use the interface shown below.

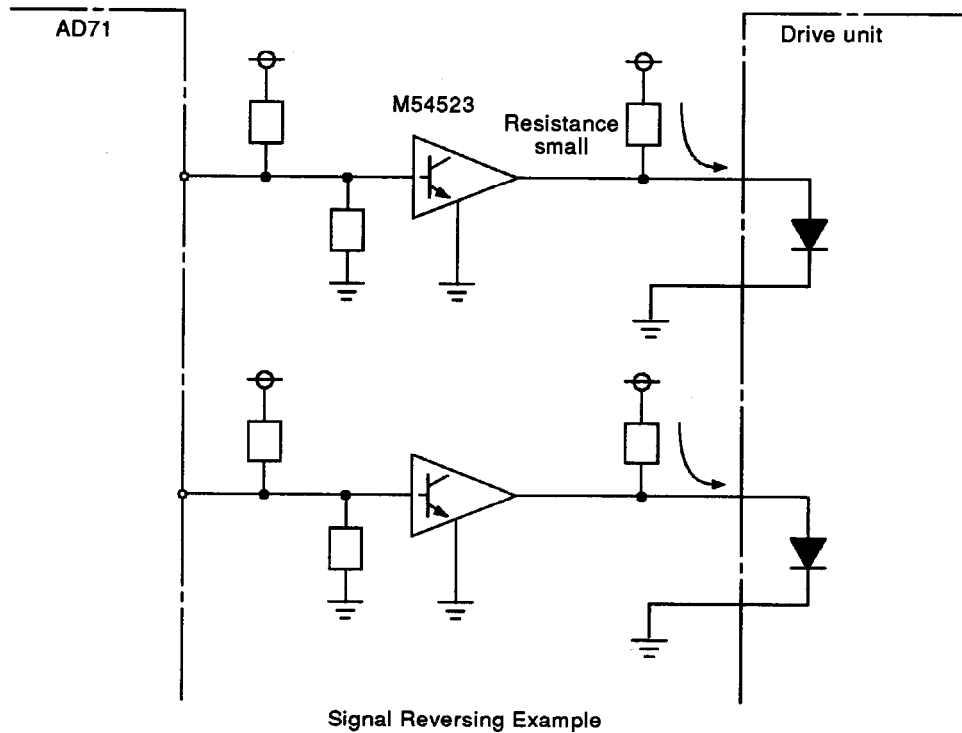

- (3) The AD71 pin numbers in parentheses are for the Y axis.
- (4) For other signal wires of the drive unit. Refer to the instruction manual for the corresponding drive unit.
- (5) Neither the AD71S2 nor A1SD71-S2 type positioning module has a manual pulse generator operation function. When using these positioning modules, use manual pulse generator connection terminals 1A, 1B to 4A and 4B as external signals (control switching enable signal, control switching signal).

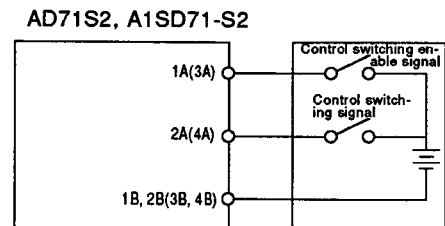
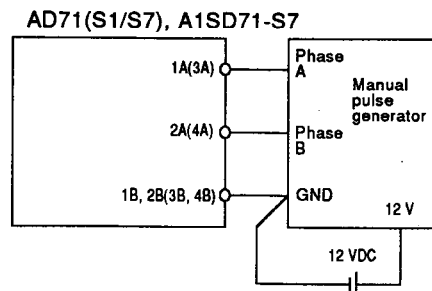

3.1 Connection with MELDAS-S1

Shown below is the diagram of connections between the AD71S1 and the MELDAS-S1.

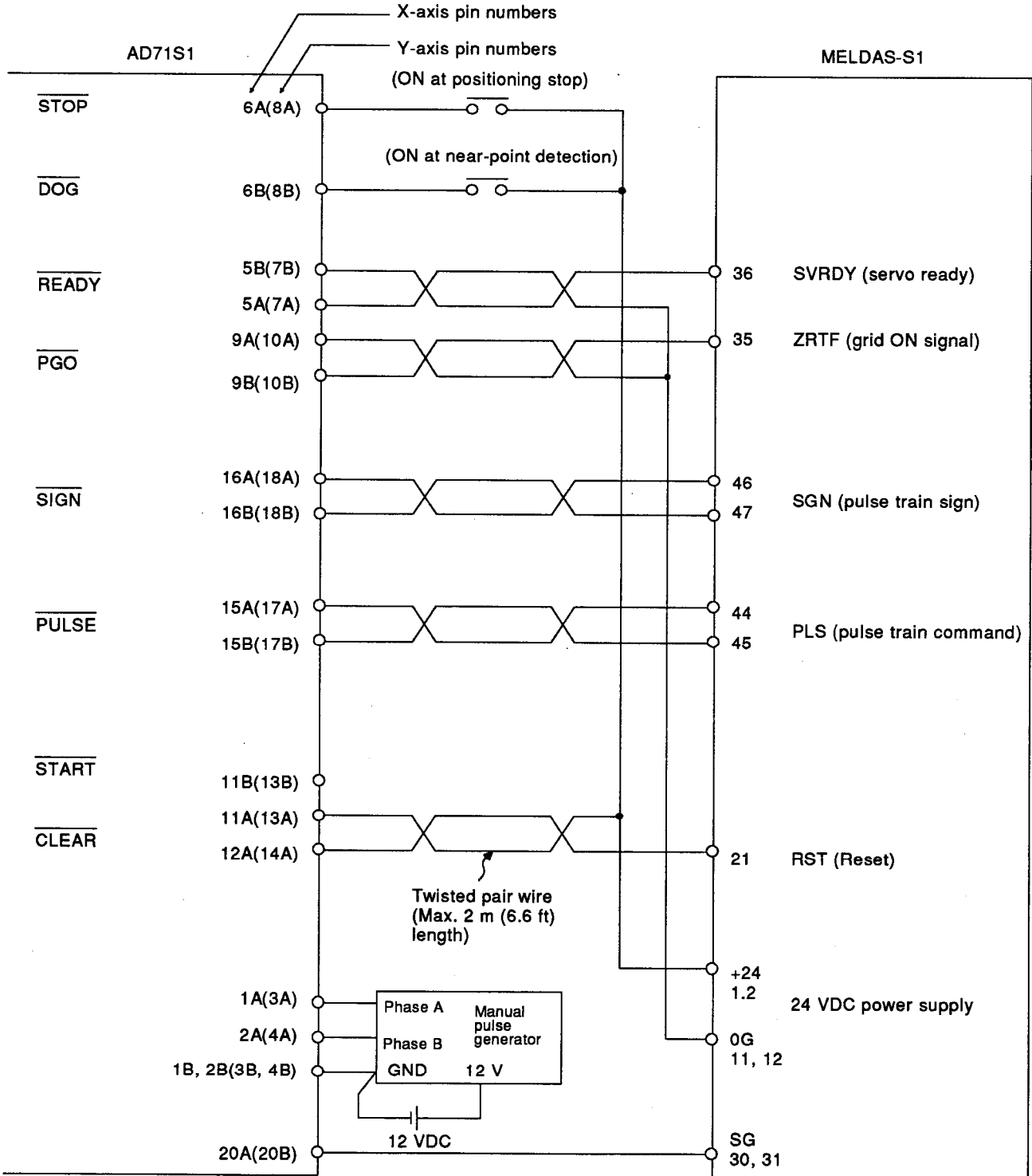

3.2 Connection with Mitsubishi MELSERVO-H

Set the AD71 to A-type output.

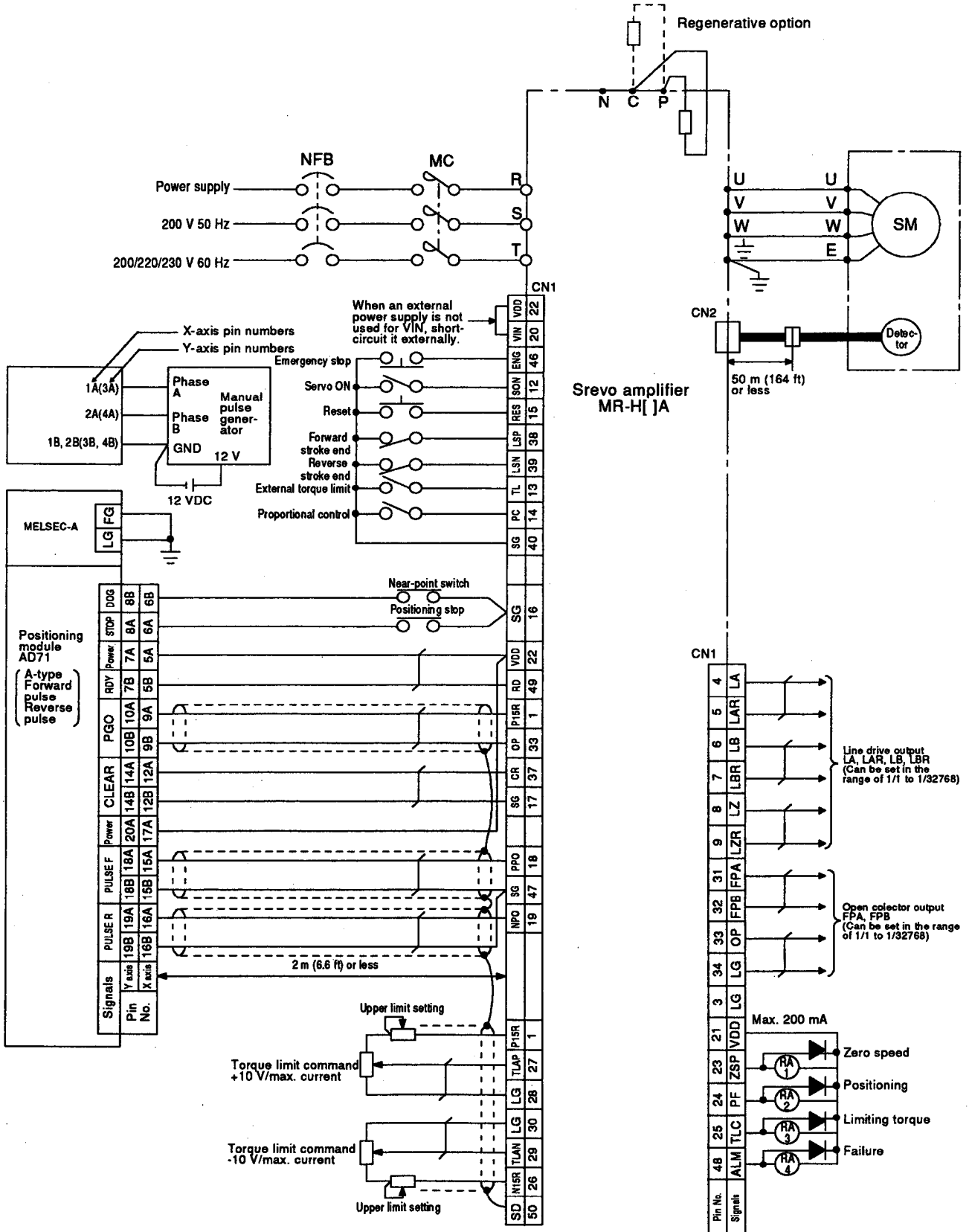



3.4 Connection with Mitsubishi MELSERVO-SA

Set the AD71 to A-type output.

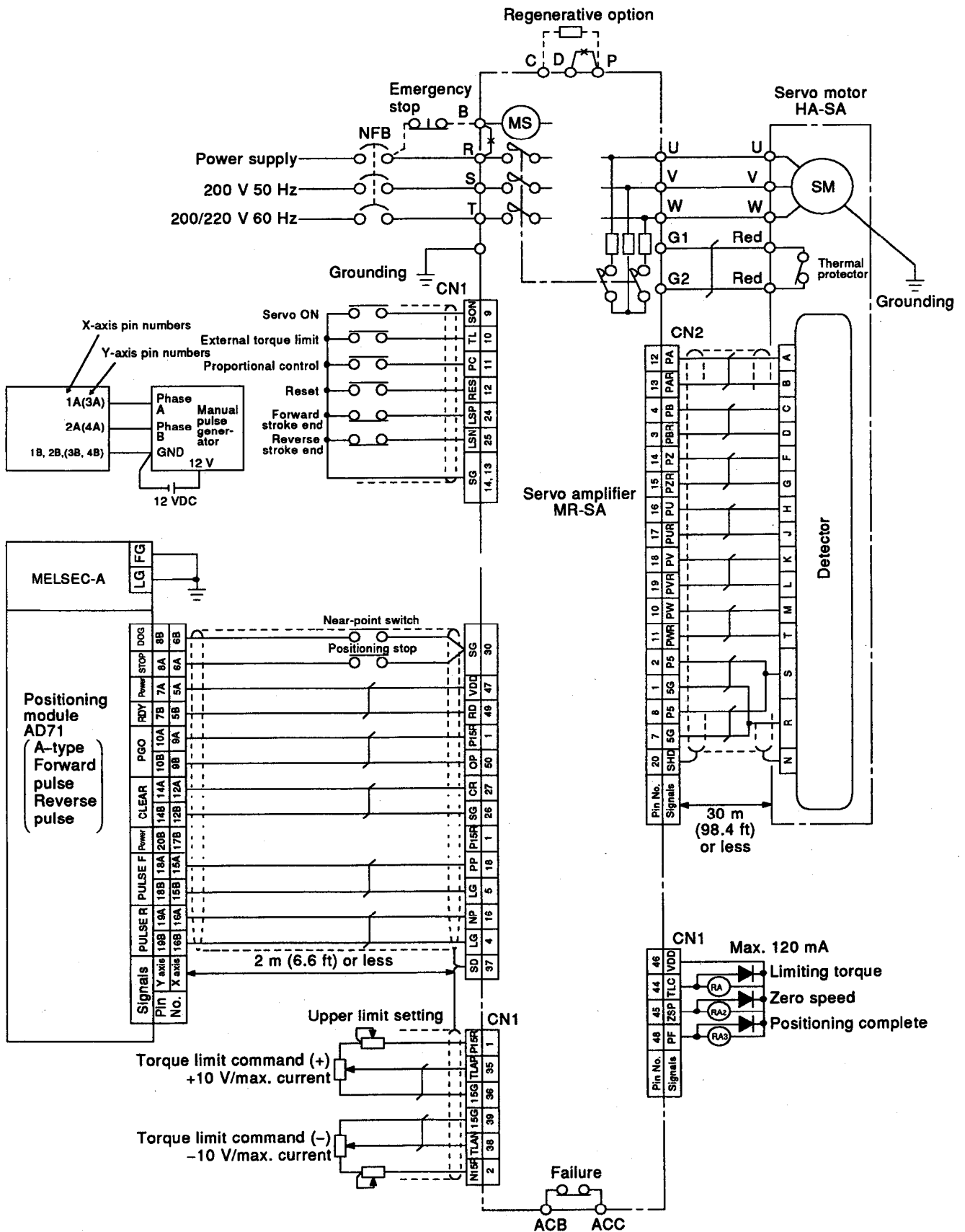

3.5 Connection with Mitsubishi MELSERVO-SA-KL

Set the AD71 to A-type output.

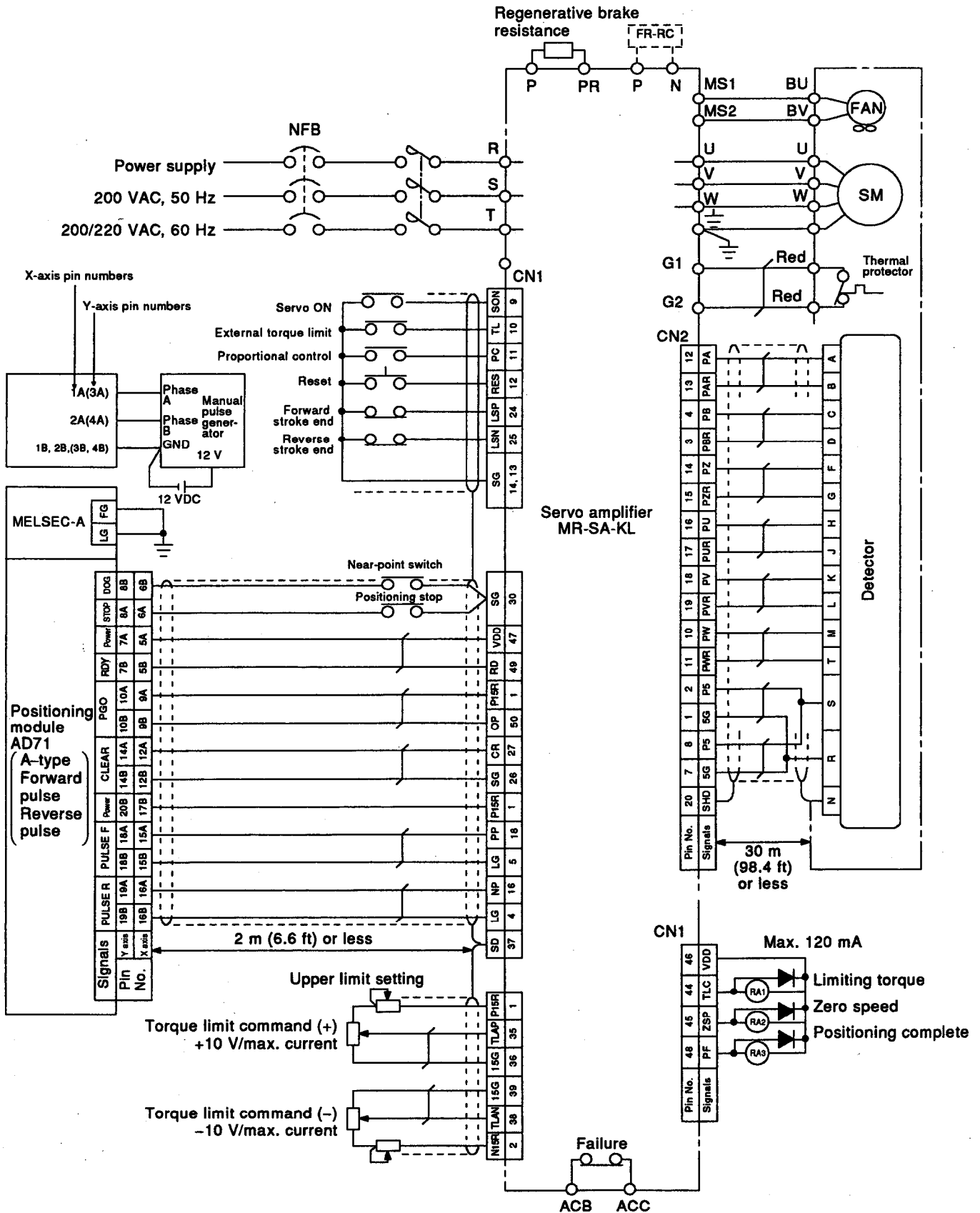



3.6 Connection with Mitsubishi MELSERVO-SC

Set the AD71 to A-type output.

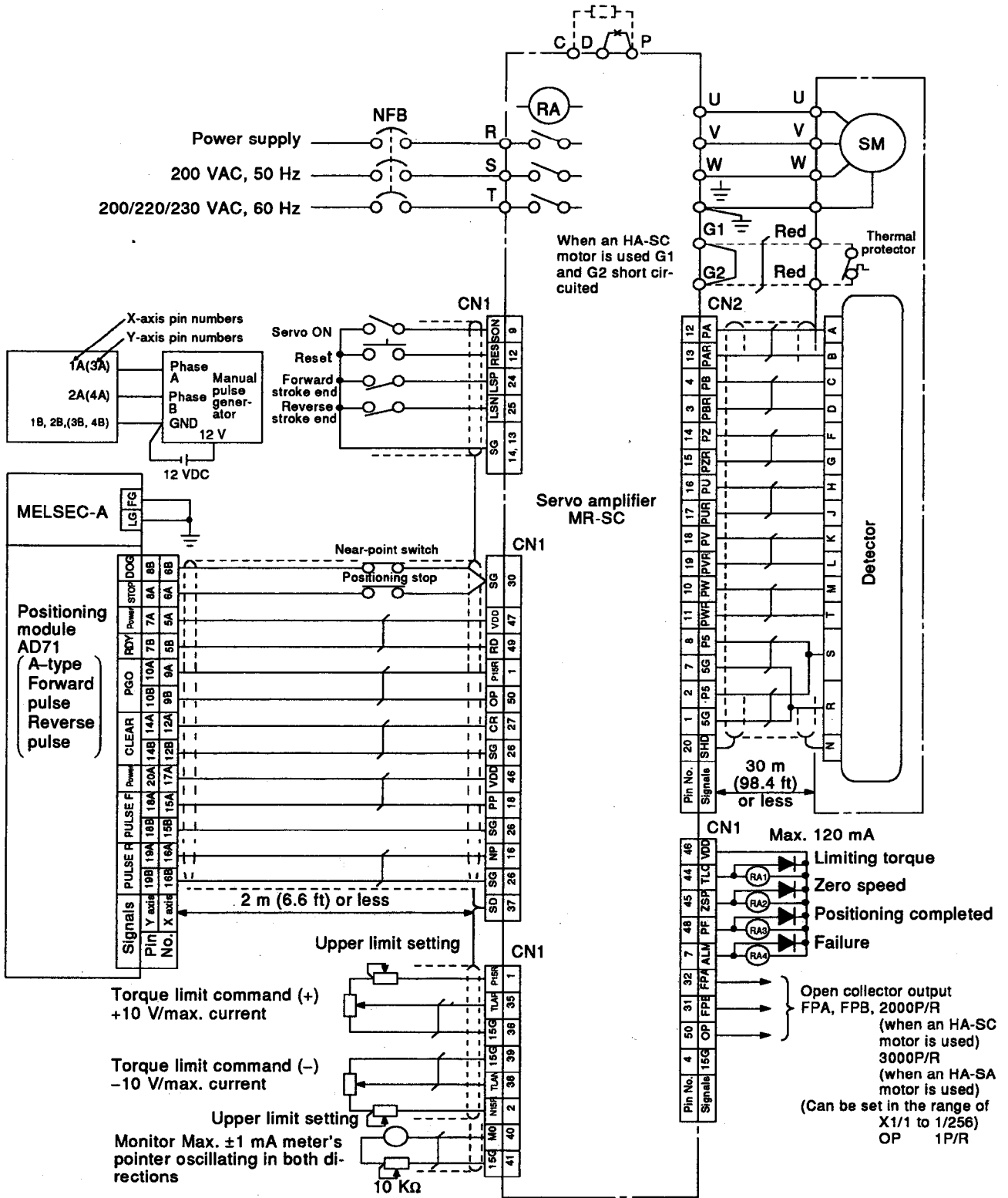

3.7 Connection with Mitsubishi MELSERVO-VA

Set the AD71 to A-type output.

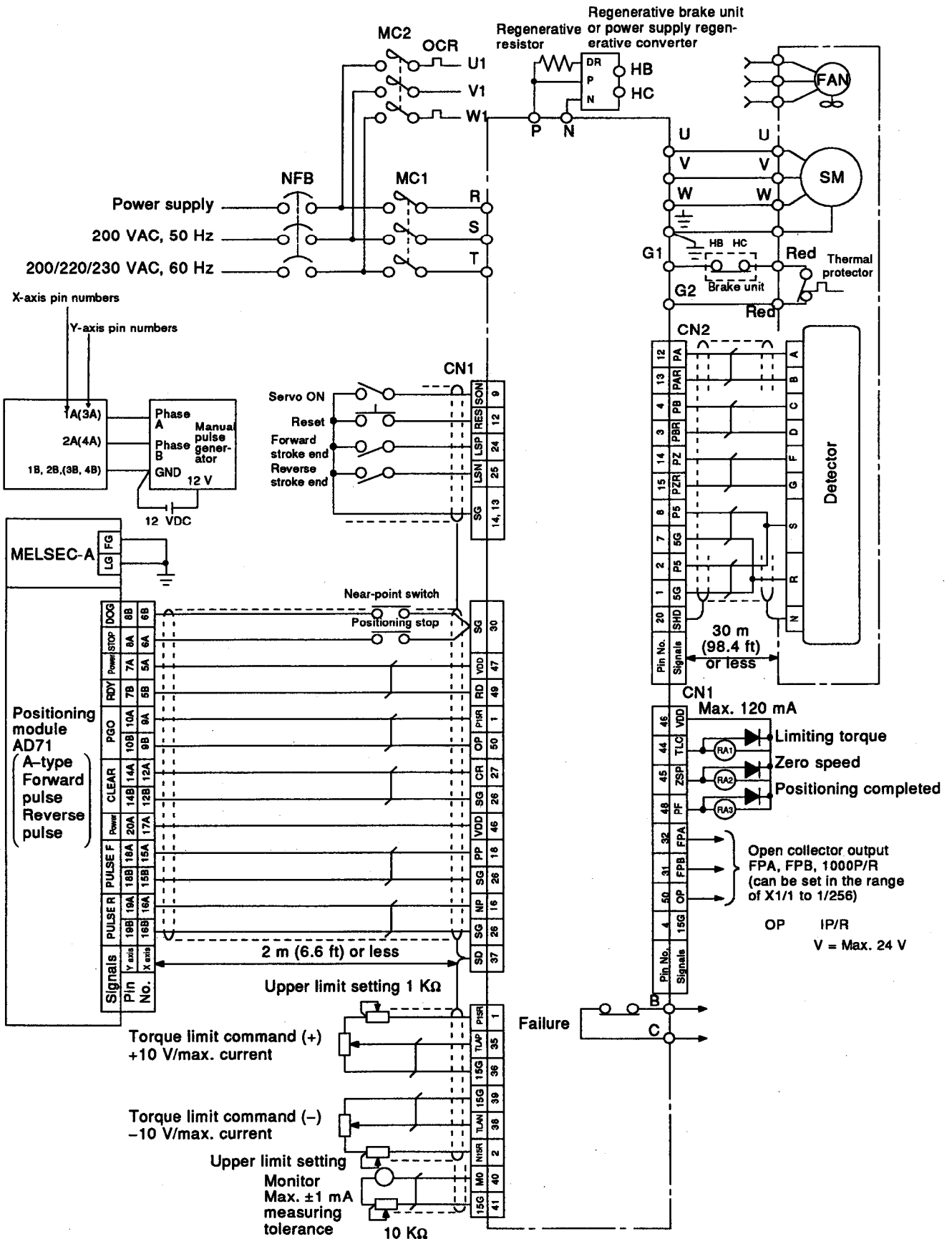

3.8 Connection with Oriental's stepping motor

Set the AD71 with a motor to A-type output.

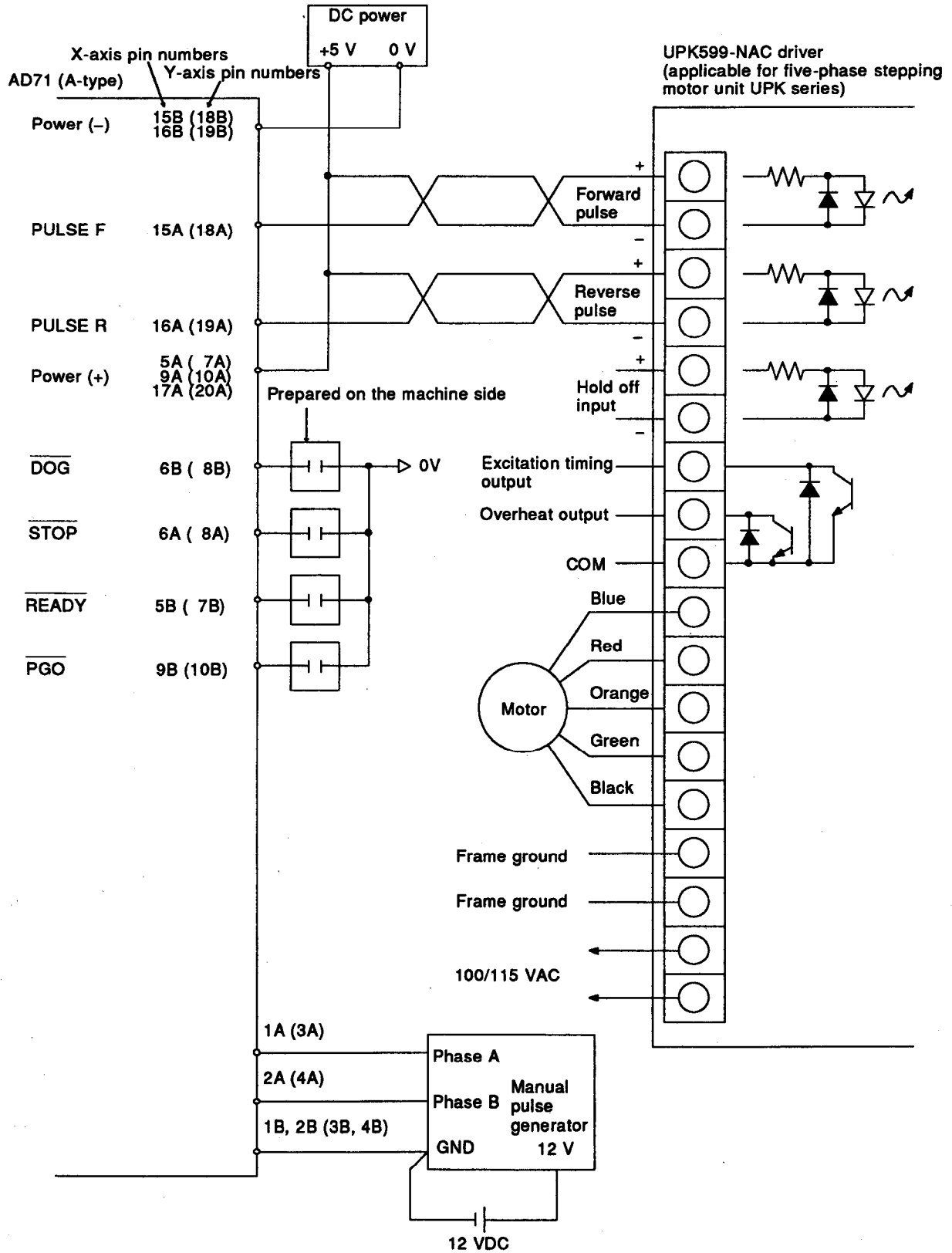

3.9 Connection with Oriental's AC servo motor

Set the AD71 with a motor to A-type output.

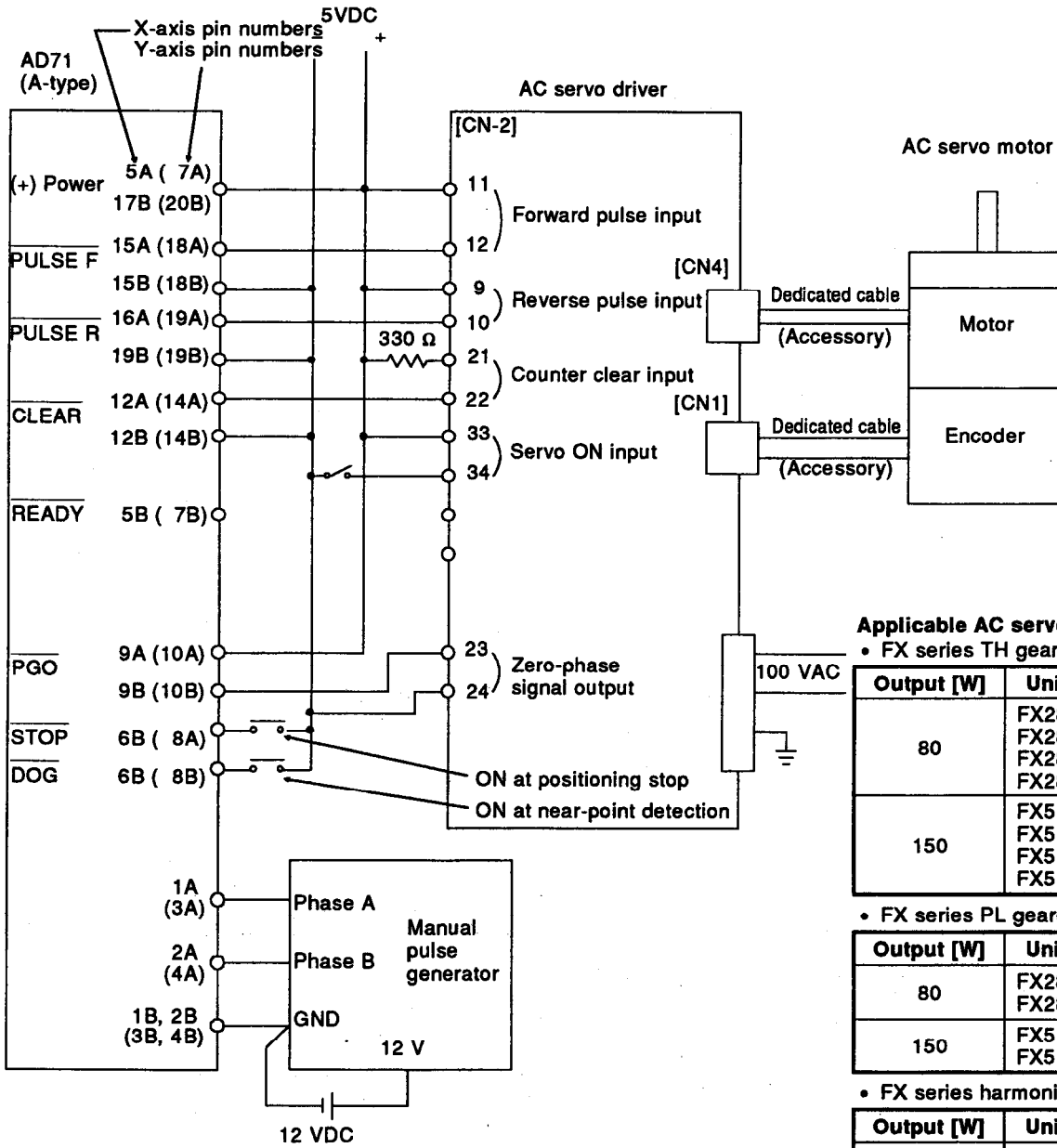

(Use multi-core twisted-pair cable for wiring.)

Applicable AC servo unit models  
 • FX series TH geared type

Output [W]	Unit Model No.
80	FX280A-TG5
	FX280A-TG10
	FX280A-TG20
	FX280A-TG30
150	FX5150A-TG5
	FX5150A-TG10
	FX5150A-TG20
	FX5150A-TG30

• FX series PL geared type

Output [W]	Unit Model No.
80	FX280A-PG7, 2
	FX280A-PG36
150	FX5150A-PG7, 2
	FX5150A-PG36

• FX series harmonic geared type

Output [W]	Unit Model No.
50	FX250A-HG50
	FX250A-HG100
150	FX5150A-HG50
	FX5150A-HG100

• FX series round shaft type

Output [W]	Unit Model No.
50	FX250-A
80	FX280-A
100	FX4100-A
200	FX4200-A

3.10 Connection with Toei Electric's BS Servo Amplifier

Shown below is the diagram of connections between the AD71 and Toei Electric's BS servo amplifier (VLASE-[ ][ ][P]).

The BS servo amplifier should be used in the positioning control mode (P mode).

Set the AD71 to A-type output.

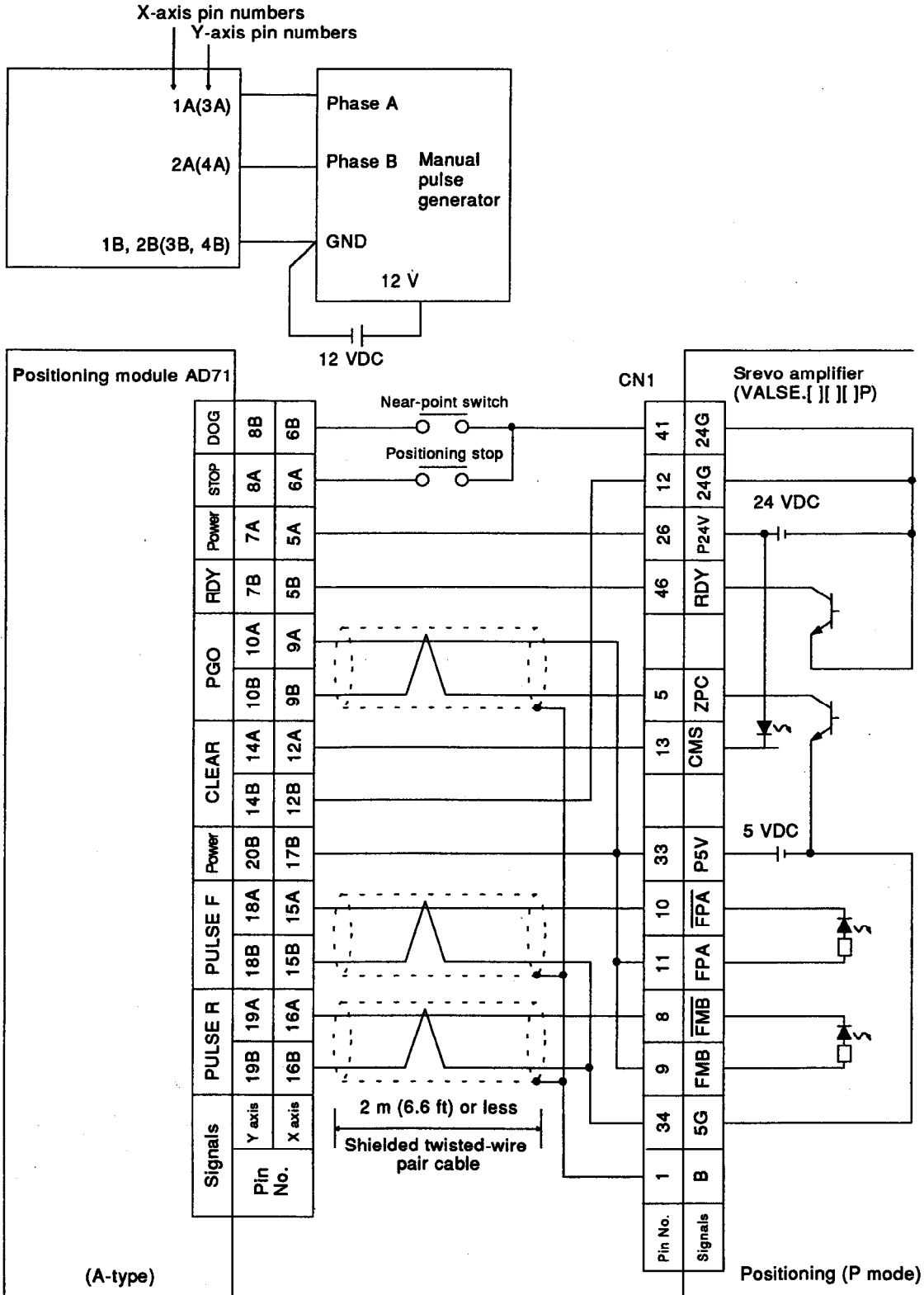

3.11 Connection with Nikki Denso's AC SERVO CONTROLLER

The connecting method to Nikki Denso's AC SERVO CONTROLLER NPSA-T is shown below.  
Set the AD71 to A-type output.

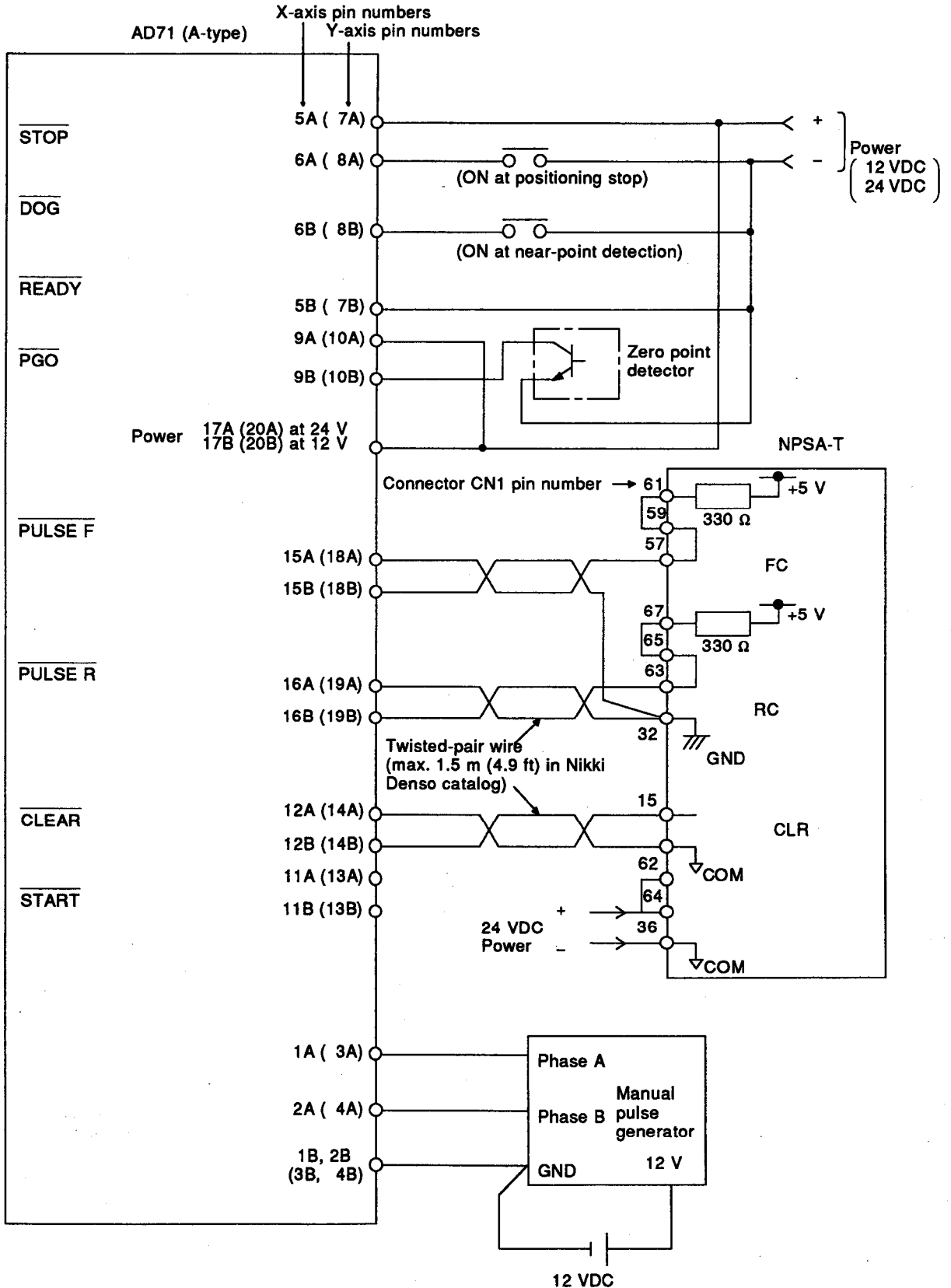

3.12 Connection with Yasukawa Electric's PACK-10C

The connecting method to PACK-10C is shown below. Set the AD71 to B-type output.  
Set the PULSE and SIGN to 5 V inside POSITION PACK.

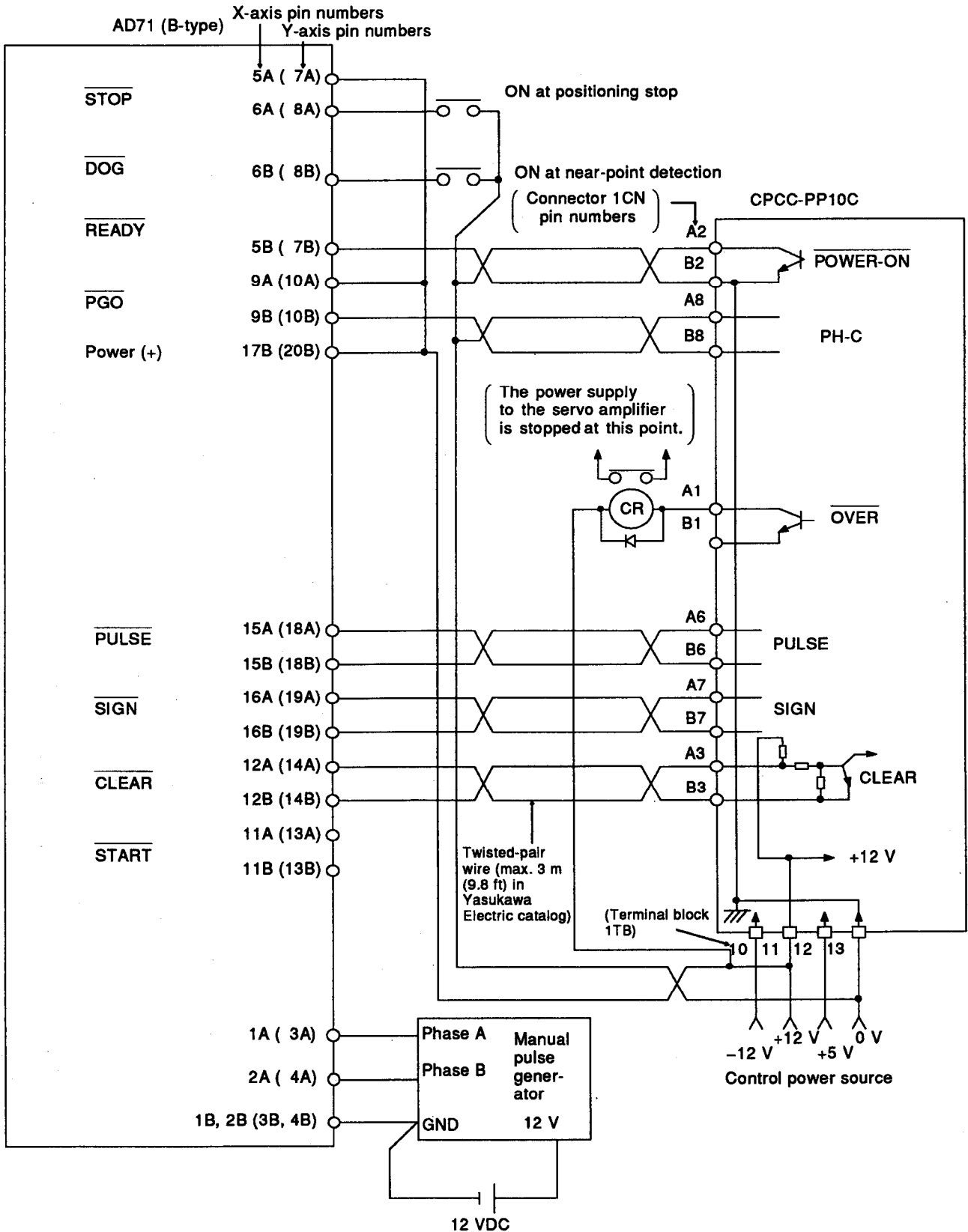

APPENDIX 4 OUTSIDE DIMENSIONS

(1) AD71(S1/S2/S7)

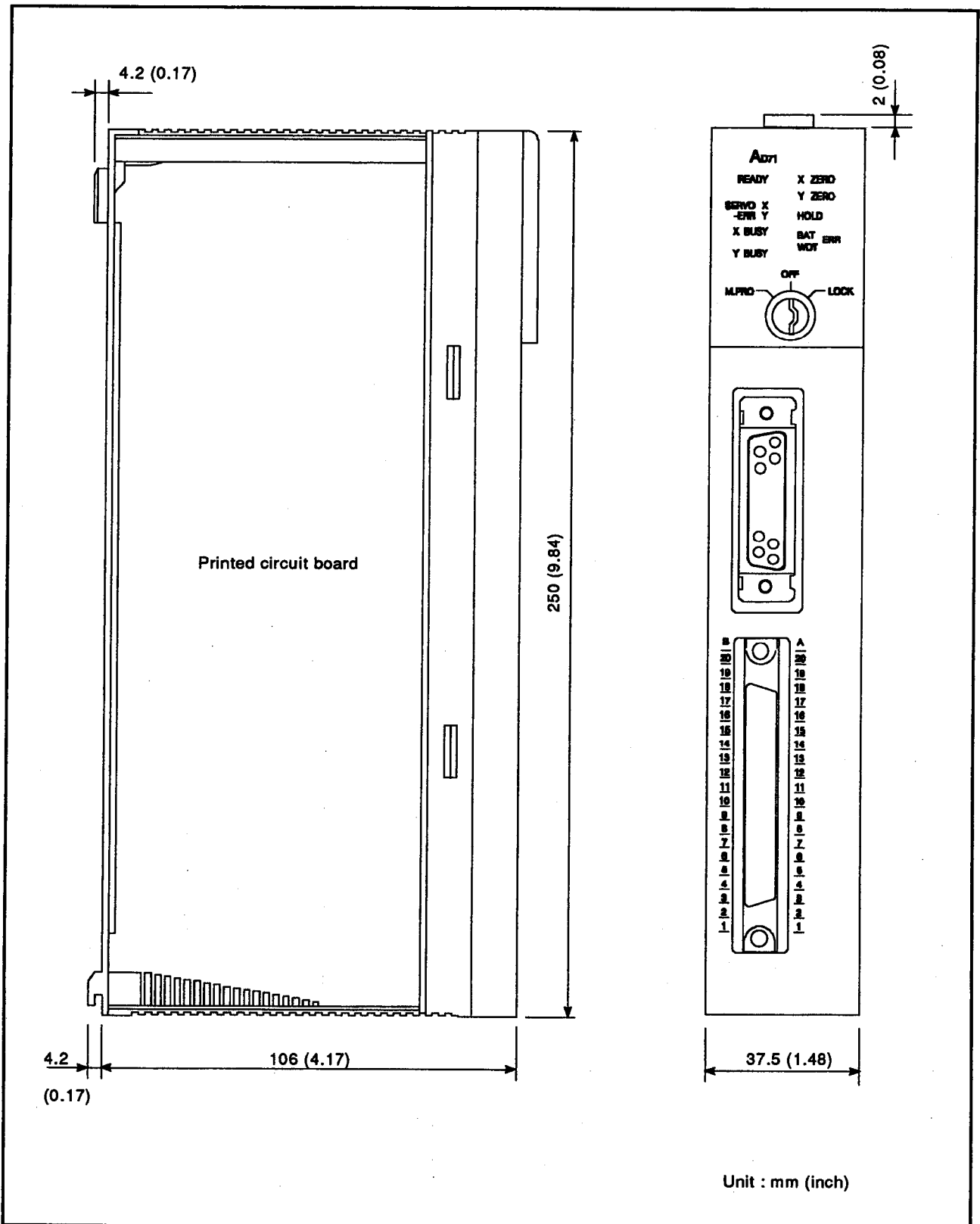



(2) A1SD71-S2(S7)

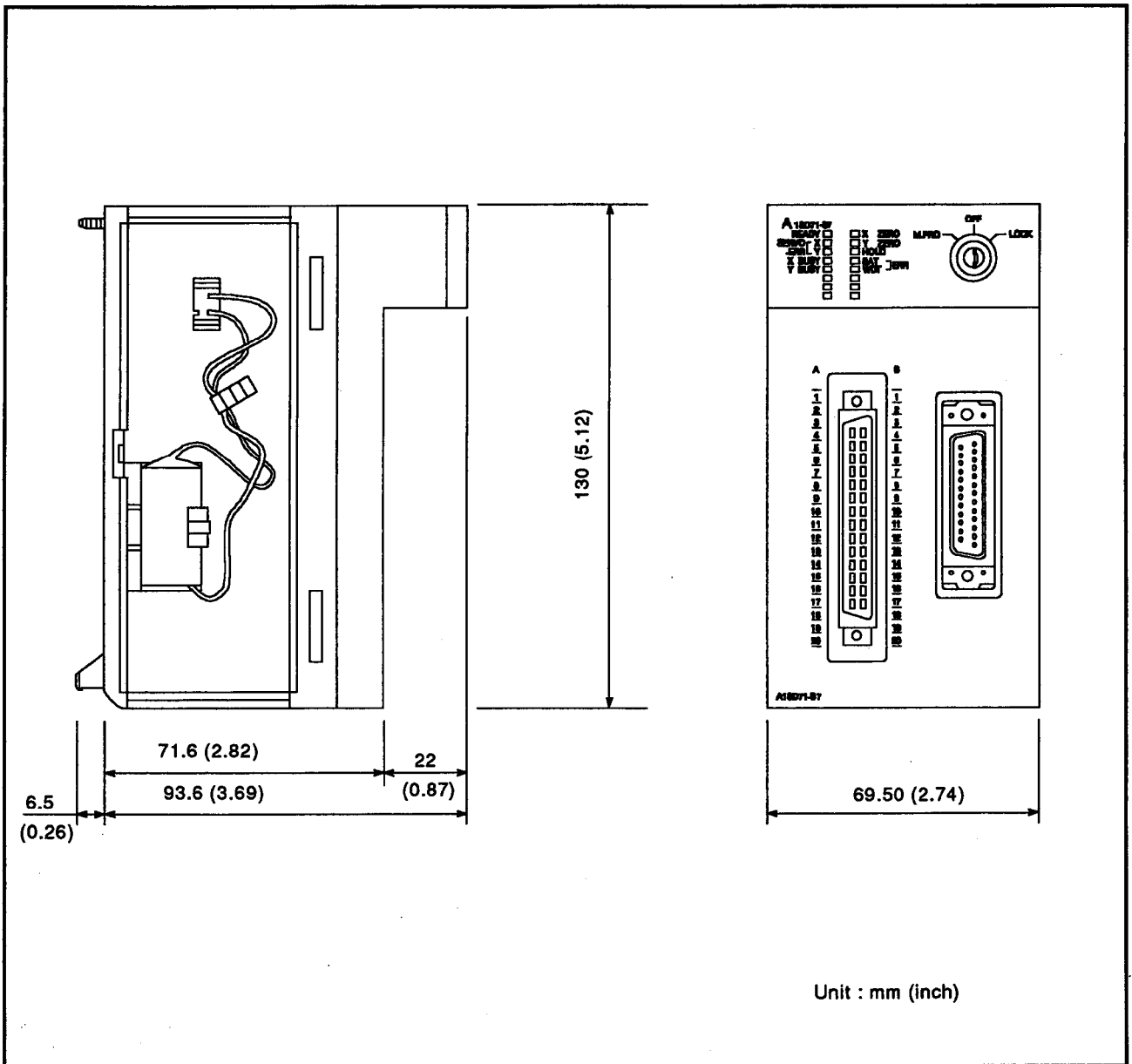

(3) Manual pulse generator

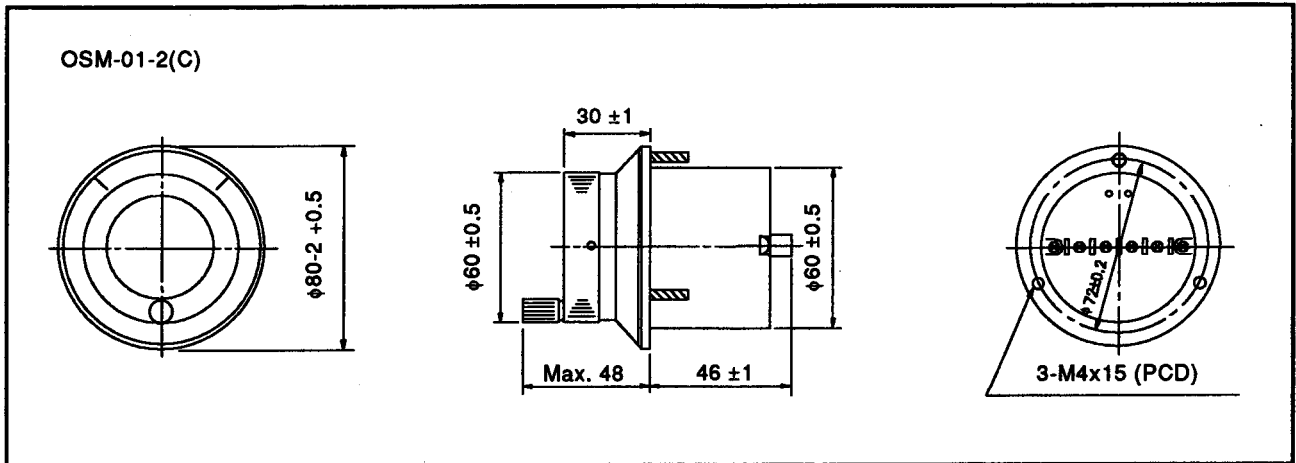

**APPENDIX 5 POSITIONING DATA NUMBER  
AND BUFFER MEMORY ADDRESS CONVERSION TABLE**

**Positioning Data Number and Buffer Memory Address Conversion Table (continued)**

Data No.	(X Axis)					(Y Axis)				
	Positioning Information	Positioning Speed	Dwell Time	Positioning Lower	Address Upper	Positioning Information	Positioning Speed	Dwell Time	Positioning Lower	Address Upper
1	3872	4272	4672	5072	5073	5872	6272	6672	7072	7073
2	3873	4273	4673	5074	5075	5873	6273	6673	7074	7075
3	3874	4274	4674	5076	5077	5874	6274	6674	7076	7077
4	3875	4275	4675	5078	5079	5875	6275	6675	7078	7079
5	3876	4276	4676	5080	5081	5876	6276	6676	7080	7081
6	3877	4277	4677	5082	5083	5877	6277	6677	7082	7083
7	3878	4278	4678	5084	5085	5878	6278	6678	7084	7085
8	3879	4279	4679	5086	5087	5879	6279	6679	7086	7087
9	3880	4280	4680	5088	5089	5880	6280	6680	7088	7089
10	3881	4281	4681	5090	5091	5881	6281	6681	7090	7091
11	3882	4282	4682	5092	5093	5882	6282	6682	7092	7093
12	3883	4283	4683	5094	5095	5883	6283	6683	7094	7095
13	3884	4284	4684	5096	5097	5884	6284	6684	7096	7097
14	3885	4285	4685	5098	5099	5885	6285	6685	7098	7099
15	3886	4286	4686	5100	5101	5886	6286	6686	7100	7101
16	3887	4287	4687	5102	5103	5887	6287	6687	7102	7103
17	3888	4288	4688	5104	5105	5888	6288	6688	7104	7105
18	3889	4289	4689	5106	5107	5889	6289	6689	7106	7107
19	3890	4290	4690	5108	5109	5890	6290	6690	7108	7109
20	3891	4291	4691	5110	5111	5891	6291	6691	7110	7111
21	3892	4292	4692	5112	5113	5892	6292	6692	7112	7113
22	3893	4293	4693	5114	5115	5893	6293	6693	7114	7115
23	3894	4294	4694	5116	5117	5894	6294	6694	7116	7117
24	3895	4295	4695	5118	5119	5895	6295	6695	7118	7119
25	3896	4296	4696	5120	5121	5896	6296	6696	7120	7121
26	3897	4297	4697	5122	5123	5897	6297	6697	7122	7123
27	3898	4298	4698	5124	5125	5898	6298	6698	7124	7125
28	3899	4299	4699	5126	5127	5899	6299	6699	7126	7127
29	3900	4300	4700	5128	5129	5900	6300	6700	7128	7129
30	3901	4301	4701	5130	5131	5901	6301	6701	7130	7131
31	3902	4302	4702	5132	5133	5902	6302	6702	7132	7133
32	3903	4303	4703	5134	5135	5903	6303	6703	7134	7135
33	3904	4304	4704	5136	5137	5904	6304	6704	7136	7137
34	3905	4305	4705	5138	5139	5905	6305	6705	7138	7139
35	3906	4306	4706	5140	5141	5906	6306	6706	7140	7141
36	3907	4307	4707	5142	5143	5907	6307	6707	7142	7143
37	3908	4308	4708	5144	5145	5908	6308	6708	7144	7145
38	3909	4309	4709	5146	5147	5909	6309	6709	7146	7147
39	3910	4310	4710	5148	5149	5910	6310	6710	7148	7149
40	3911	4311	4711	5150	5151	5911	6311	6711	7150	7151
41	3912	4312	4712	5152	5153	5912	6312	6712	7152	7153
42	3913	4313	4713	5154	5155	5913	6313	6713	7154	7155
43	3914	4314	4714	5156	5157	5914	6314	6714	7156	7157
44	3915	4315	4715	5158	5159	5915	6315	6715	7158	7159
45	3916	4316	4716	5160	5161	5916	6316	6716	7160	7161
46	3917	4317	4717	5162	5163	5917	6317	6717	7162	7163
47	3918	4318	4718	5164	5165	5918	6318	6718	7164	7165
48	3919	4319	4719	5166	5167	5919	6319	6719	7166	7167
49	3920	4320	4720	5168	5169	5920	6320	6720	7168	7169
50	3921	4321	4721	5170	5171	5921	6321	6721	7170	7171

**Positioning Data Number and Buffer Memory Address Conversion Table (continued)**

Data No.	(X Axis)					(Y Axis)				
	Positioning Information	Positioning Speed	Dwell Time	Positioning Lower	Address Upper	Positioning Information	Positioning Speed	Dwell Time	Positioning Lower	Address Upper
51	3922	4322	4722	5172	5173	5922	6322	6722	7172	7173
52	3923	4323	4723	5174	5175	5923	6323	6723	7174	7175
53	3924	4324	4724	5176	5177	5924	6324	6724	7176	7177
54	3925	4325	4725	5178	5179	5925	6325	6725	7178	7179
55	3926	4326	4726	5180	5181	5926	6326	6726	7180	7181
56	3927	4327	4727	5182	5183	5927	6327	6727	7182	7183
57	3928	4328	4728	5184	5185	5928	6328	6728	7184	7185
58	3929	4329	4729	5186	5187	5929	6329	6729	7186	7187
59	3930	4330	4730	5188	5189	5930	6330	6730	7188	7189
60	3931	4331	4731	5190	5191	5931	6331	6731	7190	7191
61	3932	4332	4732	5192	5193	5932	6332	6732	7192	7193
62	3933	4333	4733	5194	5195	5933	6333	6733	7194	7195
63	3934	4334	4734	5196	5197	5934	6334	6734	7196	7197
64	3935	4335	4735	5198	5199	5935	6335	6735	7198	7199
65	3936	4336	4736	5200	5201	5936	6336	6736	7200	7201
66	3937	4337	4737	5202	5203	5937	6337	6737	7202	7203
67	3938	4338	4738	5204	5205	5938	6338	6738	7204	7205
68	3939	4339	4739	5206	5207	5939	6339	6739	7206	7207
69	3940	4340	4740	5208	5209	5940	6340	6740	7208	7209
70	3941	4341	4741	5210	5211	5941	6341	6741	7210	7211
71	3942	4342	4742	5212	5213	5942	6342	6742	7212	7213
72	3943	4343	4743	5214	5215	5943	6343	6743	7214	7215
73	3944	4344	4744	5216	5217	5944	6344	6744	7216	7217
74	3945	4345	4745	5218	5219	5945	6345	6745	7218	7219
75	3946	4346	4746	5220	5221	5946	6346	6746	7220	7221
76	3947	4347	4747	5222	5223	5947	6347	6747	7222	7223
77	3948	4348	4748	5224	5225	5948	6348	6748	7224	7225
78	3949	4349	4749	5226	5227	5949	6349	6749	7226	7227
79	3950	4350	4750	5228	5229	5950	6350	6750	7228	7229
80	3951	4351	4751	5230	5231	5951	6351	6751	7230	7231
81	3952	4352	4752	5232	5233	5952	6352	6752	7232	7233
82	3953	4353	4753	5234	5235	5953	6353	6753	7234	7235
83	3954	4354	4754	5236	5237	5954	6354	6754	7236	7237
84	3955	4355	4755	5238	5239	5955	6355	6755	7238	7239
85	3956	4356	4756	5240	5241	5956	6356	6756	7240	7241
86	3957	4357	4757	5242	5243	5957	6357	6757	7242	7243
87	3958	4358	4758	5244	5245	5958	6358	6758	7244	7245
88	3959	4359	4759	5246	5247	5959	6359	6759	7246	7247
89	3960	4360	4760	5248	5249	5960	6360	6760	7248	7249
90	3961	4361	4761	5250	5251	5961	6361	6761	7250	7251
91	3962	4362	4762	5252	5253	5962	6362	6762	7252	7253
92	3963	4363	4763	5254	5255	5963	6363	6763	7254	7255
93	3964	4364	4764	5256	5257	5964	6364	6764	7256	7257
94	3965	4365	4765	5258	5259	5965	6365	6765	7258	7259
95	3966	4366	4766	5260	5261	5966	6366	6766	7260	7261
96	3967	4367	4767	5262	5263	5967	6367	6767	7262	7263
97	3968	4368	4768	5264	5265	5968	6368	6768	7264	7265
98	3969	4369	4769	5266	5267	5969	6369	6769	7266	7267
99	3970	4370	4770	5268	5269	5970	6370	6770	7268	7269
100	3971	4371	4771	5270	5271	5971	6371	6771	7270	7271

Positioning Data Number and Buffer Memory Address Conversion Table (continued)

Data No.	(X Axis)					(Y Axis)				
	Positioning Information	Positioning Speed	Dwell Time	Positioning Lower	Address Upper	Positioning Information	Positioning Speed	Dwell Time	Positioning Lower	Address Upper
101	3972	4372	4772	5272	5273	5972	6372	6772	7272	7273
102	3973	4373	4773	5274	5275	5973	6373	6773	7274	7275
103	3974	4374	4774	5276	5277	5974	6374	6774	7276	7277
104	3975	4375	4775	5278	5279	5975	6375	6775	7278	7279
105	3976	4376	4776	5280	5281	5976	6376	6776	7280	7281
106	3977	4377	4777	5282	5283	5977	6377	6777	7282	7283
107	3978	4378	4778	5284	5285	5978	6378	6778	7284	7285
108	3979	4379	4779	5286	5287	5979	6379	6779	7286	7287
109	3980	4380	4780	5288	5289	5980	6380	6780	7288	7289
110	3981	4381	4781	5290	5291	5981	6381	6781	7290	7291
111	3982	4382	4782	5292	5293	5982	6382	6782	7292	7293
112	3983	4383	4783	5294	5295	5983	6383	6783	7294	7295
113	3984	4384	4784	5296	5297	5984	6384	6784	7296	7297
114	3985	4385	4785	5298	5299	5985	6385	6785	7298	7299
115	3986	4386	4786	5300	5301	5986	6386	6786	7300	7301
116	3987	4387	4787	5302	5303	5987	6387	6787	7302	7303
117	3988	4388	4788	5304	5305	5988	6388	6788	7304	7305
118	3989	4389	4789	5306	5307	5989	6389	6789	7306	7307
119	3990	4390	4790	5308	5309	5990	6390	6790	7308	7309
120	3991	4391	4791	5310	5311	5991	6391	6791	7310	7311
121	3992	4392	4792	5312	5313	5992	6392	6792	7312	7313
122	3993	4393	4793	5314	5315	5993	6393	6793	7314	7315
123	3994	4394	4794	5316	5317	5994	6394	6794	7316	7317
124	3995	4395	4795	5318	5319	5995	6395	6795	7318	7319
125	3996	4396	4796	5320	5321	5996	6396	6796	7320	7321
126	3997	4397	4797	5322	5323	5997	6397	6797	7322	7323
127	3998	4398	4798	5324	5325	5998	6398	6798	7324	7325
128	3999	4399	4799	5326	5327	5999	6399	6799	7326	7327
129	4000	4400	4800	5328	5329	6000	6400	6800	7328	7329
130	4001	4401	4801	5330	5331	6001	6401	6801	7330	7331
131	4002	4402	4802	5332	5333	6002	6402	6802	7332	7333
132	4003	4403	4803	5334	5335	6003	6403	6803	7334	7335
133	4004	4404	4804	5336	5337	6004	6404	6804	7336	7337
134	4005	4405	4805	5338	5339	6005	6405	6805	7338	7339
135	4006	4406	4806	5340	5341	6006	6406	6806	7340	7341
136	4007	4407	4807	5342	5343	6007	6407	6807	7342	7343
137	4008	4408	4808	5344	5345	6008	6408	6808	7344	7345
138	4009	4409	4809	5346	5347	6009	6409	6809	7346	7347
139	4010	4410	4810	5348	5349	6010	6410	6810	7348	7349
140	4011	4411	4811	5350	5351	6011	6411	6811	7350	7351
141	4012	4412	4812	5352	5353	6012	6412	6812	7352	7353
142	4013	4413	4813	5354	5355	6013	6413	6813	7354	7355
143	4014	4414	4814	5356	5357	6014	6414	6814	7356	7357
144	4015	4415	4815	5358	5359	6015	6415	6815	7358	7359
145	4016	4416	4816	5360	5361	6016	6416	6816	7360	7361
146	4017	4417	4817	5362	5363	6017	6417	6817	7362	7363
147	4018	4418	4818	5364	5365	6018	6418	6818	7364	7365
148	4019	4419	4819	5366	5367	6019	6419	6819	7366	7367
149	4020	4420	4820	5368	5369	6020	6420	6820	7368	7369
150	4021	4421	4821	5370	5371	6021	6421	6821	7370	7371

Positioning Data Number and Buffer Memory Address Conversion Table (continued)

Data No.	(X Axis)					(Y Axis)				
	Positioning Information	Positioning Speed	Dwell Time	Positioning Lower	Address Upper	Positioning Information	Positioning Speed	Dwell Time	Positioning Lower	Address Upper
151	4022	4422	4822	5372	5373	6022	6422	6822	7372	7373
152	4023	4423	4823	5374	5375	6023	6423	6823	7374	7375
153	4024	4424	4824	5376	5377	6024	6424	6824	7376	7377
154	4025	4425	4825	5378	5379	6025	6425	6825	7378	7379
155	4026	4426	4826	5380	5381	6026	6426	6826	7380	7381
156	4027	4427	4827	5382	5383	6027	6427	6827	7382	7383
157	4028	4428	4828	5384	5385	6028	6428	6828	7384	7385
158	4029	4429	4829	5386	5387	6029	6429	6829	7386	7387
159	4030	4430	4830	5388	5389	6030	6430	6830	7388	7389
160	4031	4431	4831	5390	5391	6031	6431	6831	7390	7391
161	4032	4432	4832	5392	5393	6032	6432	6832	7392	7393
162	4033	4433	4833	5394	5395	6033	6433	6833	7394	7395
163	4034	4434	4834	5396	5397	6034	6434	6834	7396	7397
164	4035	4435	4835	5398	5399	6035	6435	6835	7398	7399
165	4036	4436	4836	5400	5401	6036	6436	6836	7400	7401
166	4037	4437	4837	5402	5403	6037	6437	6837	7402	7403
167	4038	4438	4838	5404	5405	6038	6438	6838	7404	7405
168	4039	4439	4839	5406	5407	6039	6439	6839	7406	7407
169	4040	4440	4840	5408	5409	6040	6440	6840	7408	7409
170	4041	4441	4841	5410	5411	6041	6441	6841	7410	7411
171	4042	4442	4842	5412	5413	6042	6442	6842	7412	7413
172	4043	4443	4843	5414	5415	6043	6443	6843	7414	7415
173	4044	4444	4844	5416	5417	6044	6444	6844	7416	7417
174	4045	4445	4845	5418	5419	6045	6445	6845	7418	7419
175	4046	4446	4846	5420	5421	6046	6446	6846	7420	7421
176	4047	4447	4847	5422	5423	6047	6447	6847	7422	7423
177	4048	4448	4848	5424	5425	6048	6448	6848	7424	7425
178	4049	4449	4849	5426	5427	6049	6449	6849	7426	7427
179	4050	4450	4850	5428	5429	6050	6450	6850	7428	7429
180	4051	4451	4851	5430	5431	6051	6451	6851	7430	7431
181	4052	4452	4852	5432	5433	6052	6452	6852	7432	7433
182	4053	4453	4853	5434	5435	6053	6453	6853	7434	7435
183	4054	4454	4854	5436	5437	6054	6454	6854	7436	7437
184	4055	4455	4855	5438	5439	6055	6455	6855	7438	7439
185	4056	4456	4856	5440	5441	6056	6456	6856	7440	7441
186	4057	4457	4857	5442	5443	6057	6457	6857	7442	7443
187	4058	4458	4858	5444	5445	6058	6458	6858	7444	7445
188	4059	4459	4859	5446	5447	6059	6459	6859	7446	7447
189	4060	4460	4860	5448	5449	6060	6460	6860	7448	7449
190	4061	4461	4861	5450	5451	6061	6461	6861	7450	7451
191	4062	4462	4862	5452	5453	6062	6462	6862	7452	7453
192	4063	4463	4863	5454	5455	6063	6463	6863	7454	7455
193	4064	4464	4864	5456	5457	6064	6464	6864	7456	7457
194	4065	4465	4865	5458	5459	6065	6465	6865	7458	7459
195	4066	4466	4866	5460	5461	6066	6466	6866	7460	7461
196	4067	4467	4867	5462	5463	6067	6467	6867	7462	7463
197	4068	4468	4868	5464	5465	6068	6468	6868	7464	7465
198	4069	4469	4869	5466	5467	6069	6469	6869	7466	7467
199	4070	4470	4870	5468	5469	6070	6470	6870	7468	7469
200	4071	4471	4871	5470	5471	6071	6471	6871	7470	7471

Positioning Data Number and Buffer Memory Address Conversion Table (continued)

Data No.	(X Axis)					(Y Axis)				
	Positioning Information	Positioning Speed	Dwell Time	Positioning Lower	Address Upper	Positioning Information	Positioning Speed	Dwell Time	Positioning Lower	Address Upper
201	4072	4472	4872	5472	5473	6072	6472	6872	7472	7473
202	4073	4473	4873	5474	5475	6073	6473	6873	7474	7475
203	4074	4474	4874	5476	5477	6074	6474	6874	7476	7477
204	4075	4475	4875	5478	5479	6075	6475	6875	7478	7479
205	4076	4476	4876	5480	5481	6076	6476	6876	7480	7481
206	4077	4477	4877	5482	5483	6077	6477	6877	7482	7483
207	4078	4478	4878	5484	5485	6078	6478	6878	7484	7485
208	4079	4479	4879	5486	5487	6079	6479	6879	7486	7487
209	4080	4480	4880	5488	5489	6080	6480	6880	7488	7489
210	4081	4481	4881	5490	5491	6081	6481	6881	7490	7491
211	4082	4482	4882	5492	5493	6082	6482	6882	7492	7493
212	4083	4483	4883	5494	5495	6083	6483	6883	7494	7495
213	4084	4484	4884	5496	5497	6084	6484	6884	7496	7497
214	4085	4485	4885	5498	5499	6085	6485	6885	7498	7499
215	4086	4486	4886	5500	5501	6086	6486	6886	7500	7501
216	4087	4487	4887	5502	5503	6087	6487	6887	7502	7503
217	4088	4488	4888	5504	5505	6088	6488	6888	7504	7505
218	4089	4489	4889	5506	5507	6089	6489	6889	7506	7507
219	4090	4490	4890	5508	5509	6090	6490	6890	7508	7509
220	4091	4491	4891	5510	5511	6091	6491	6891	7510	7511
221	4092	4492	4892	5512	5513	6092	6492	6892	7512	7513
222	4093	4493	4893	5514	5515	6093	6493	6893	7514	7515
223	4094	4494	4894	5516	5517	6094	6494	6894	7516	7517
224	4095	4495	4895	5518	5519	6095	6495	6895	7518	7519
225	4096	4496	4896	5520	5521	6096	6496	6896	7520	7521
226	4097	4497	4897	5522	5523	6097	6497	6897	7522	7523
227	4098	4498	4898	5524	5525	6098	6498	6898	7524	7525
228	4099	4499	4899	5526	5527	6099	6499	6899	7526	7527
229	4100	4500	4900	5528	5529	6100	6500	6900	7528	7529
230	4101	4501	4901	5530	5531	6101	6501	6901	7530	7531
231	4102	4502	4902	5532	5533	6102	6502	6902	7532	7533
232	4103	4503	4903	5534	5535	6103	6503	6903	7534	7535
233	4104	4504	4904	5536	5537	6104	6504	6904	7536	7537
234	4105	4505	4905	5538	5539	6105	6505	6905	7538	7539
235	4106	4506	4906	5540	5541	6106	6506	6906	7540	7541
236	4107	4507	4907	5542	5543	6107	6507	6907	7542	7543
237	4108	4508	4908	5544	5545	6108	6508	6908	7544	7545
238	4109	4509	4909	5546	5547	6109	6509	6909	7546	7547
239	4110	4510	4910	5548	5549	6110	6510	6910	7548	7549
240	4111	4511	4911	5550	5551	6111	6511	6911	7550	7551
241	4112	4512	4912	5552	5553	6112	6512	6912	7552	7553
242	4113	4513	4913	5554	5555	6113	6513	6913	7554	7555
243	4114	4514	4914	5556	5557	6114	6514	6914	7556	7557
244	4115	4515	4915	5558	5559	6115	6515	6915	7558	7559
245	4116	4516	4916	5560	5561	6116	6516	6916	7560	7561
246	4117	4517	4917	5562	5563	6117	6517	6917	7562	7563
247	4118	4518	4918	5564	5565	6118	6518	6918	7564	7565
248	4119	4519	4919	5566	5567	6119	6519	6919	7566	7567
249	4120	4520	4920	5568	5569	6120	6520	6920	7568	7569
250	4121	4521	4921	5570	5571	6121	6521	6921	7570	7571

Positioning Data Number and Buffer Memory Address Conversion Table (continued)

Data No.	(X Axis)					(Y Axis)				
	Positioning Information	Positioning Speed	Dwell Time	Positioning Lower	Address Upper	Positioning Information	Positioning Speed	Dwell Time	Positioning Lower	Address Upper
251	4122	4522	4922	5572	5573	6122	6522	6922	7572	7573
252	4123	4523	4923	5574	5575	6123	6523	6923	7574	7575
253	4124	4524	4924	5576	5577	6124	6524	6924	7576	7577
254	4125	4525	4925	5578	5579	6125	6525	6925	7578	7579
255	4126	4526	4926	5580	5581	6126	6526	6926	7580	7581
256	4127	4527	4927	5582	5583	6127	6527	6927	7582	7583
257	4128	4528	4928	5584	5585	6128	6528	6928	7584	7585
258	4129	4529	4929	5586	5587	6129	6529	6929	7586	7587
259	4130	4530	4930	5588	5589	6130	6530	6930	7588	7589
260	4131	4531	4931	5590	5591	6131	6531	6931	7590	7591
261	4132	4532	4932	5592	5593	6132	6532	6932	7592	7593
262	4133	4533	4933	5594	5595	6133	6533	6933	7594	7595
263	4134	4534	4934	5596	5597	6134	6534	6934	7596	7597
264	4135	4535	4935	5598	5599	6135	6535	6935	7598	7599
265	4136	4536	4936	5600	5601	6136	6536	6936	7600	7601
266	4137	4537	4937	5602	5603	6137	6537	6937	7602	7603
267	4138	4538	4938	5604	5605	6138	6538	6938	7604	7605
268	4139	4539	4939	5606	5607	6139	6539	6939	7606	7607
269	4140	4540	4940	5608	5609	6140	6540	6940	7608	7609
270	4141	4541	4941	5610	5611	6141	6541	6941	7610	7611
271	4142	4542	4942	5612	5613	6142	6542	6942	7612	7613
272	4143	4543	4943	5614	5615	6143	6543	6943	7614	7615
273	4144	4544	4944	5616	5617	6144	6544	6944	7616	7617
274	4145	4545	4945	5618	5619	6145	6545	6945	7618	7619
275	4146	4546	4946	5620	5621	6146	6546	6946	7620	7621
276	4147	4547	4947	5622	5623	6147	6547	6947	7622	7623
277	4148	4548	4948	5624	5625	6148	6548	6948	7624	7625
278	4149	4549	4949	5626	5627	6149	6549	6949	7626	7627
279	4150	4550	4950	5628	5629	6150	6550	6950	7628	7629
280	4151	4551	4951	5630	5631	6151	6551	6951	7630	7631
281	4152	4552	4952	5632	5633	6152	6552	6952	7632	7633
282	4153	4553	4953	5634	5635	6153	6553	6953	7634	7635
283	4154	4554	4954	5636	5637	6154	6554	6954	7636	7637
284	4155	4555	4955	5638	5639	6155	6555	6955	7638	7639
285	4156	4556	4956	5640	5641	6156	6556	6956	7640	7641
286	4157	4557	4957	5642	5643	6157	6557	6957	7642	7643
287	4158	4558	4958	5644	5645	6158	6558	6958	7644	7645
288	4159	4559	4959	5646	5647	6159	6559	6959	7646	7647
289	4160	4560	4960	5648	5649	6160	6560	6960	7648	7649
290	4161	4561	4961	5650	5651	6161	6561	6961	7650	7651
291	4162	4562	4962	5652	5653	6162	6562	6962	7652	7653
292	4163	4563	4963	5654	5655	6163	6563	6963	7654	7655
293	4164	4564	4964	5656	5657	6164	6564	6964	7656	7657
294	4165	4565	4965	5658	5659	6165	6565	6965	7658	7659
295	4166	4566	4966	5660	5661	6166	6566	6966	7660	7661
296	4167	4567	4967	5662	5663	6167	6567	6967	7662	7663
297	4168	4568	4968	5664	5665	6168	6568	6968	7664	7665
298	4169	4569	4969	5666	5667	6169	6569	6969	7666	7667
299	4170	4570	4970	5668	5669	6170	6570	6970	7668	7669
300	4171	4571	4971	5670	5671	6171	6571	6971	7670	7671



**Positioning Data Number and Buffer Memory Address Conversion Table (continued)**

Data No.	Positioning Information	Positioning Speed	(X Axis)			Positioning Information	Positioning Speed	(Y Axis)		
			Dwell Time	Positioning Lower	Address Upper			Dwell Time	Positioning Lower	Address Upper
301	4172	4572	4972	5672	5673	6172	6572	6972	7672	7673
302	4173	4573	4973	5674	5675	6173	6573	6973	7674	7675
303	4174	4574	4974	5676	5677	6174	6574	6974	7676	7677
304	4175	4575	4975	5678	5679	6175	6575	6975	7678	7679
305	4176	4576	4976	5680	5681	6176	6576	6976	7680	7681
306	4177	4577	4977	5682	5683	6177	6577	6977	7682	7683
307	4178	4578	4978	5684	5685	6178	6578	6978	7684	7685
308	4179	4579	4979	5686	5687	6179	6579	6979	7686	7687
309	4180	4580	4980	5688	5689	6180	6580	6980	7688	7689
310	4181	4581	4981	5690	5691	6181	6581	6981	7690	7691
311	4182	4582	4982	5692	5693	6182	6582	6982	7692	7693
312	4183	4583	4983	5694	5695	6183	6583	6983	7694	7695
313	4184	4584	4984	5696	5697	6184	6584	6984	7696	7697
314	4185	4585	4985	5698	5699	6185	6585	6985	7698	7699
315	4186	4586	4986	5700	5701	6186	6586	6986	7700	7701
316	4187	4587	4987	5702	5703	6187	6587	6987	7702	7703
317	4188	4588	4988	5704	5705	6188	6588	6988	7704	7705
318	4189	4589	4989	5706	5707	6189	6589	6989	7706	7707
319	4190	4590	4990	5708	5709	6190	6590	6990	7708	7709
320	4191	4591	4991	5710	5711	6191	6591	6991	7710	7711
321	4192	4592	4992	5712	5713	6192	6592	6992	7712	7713
322	4193	4593	4993	5714	5715	6193	6593	6993	7714	7715
323	4194	4594	4994	5716	5717	6194	6594	6994	7716	7717
324	4195	4595	4995	5718	5719	6195	6595	6995	7718	7719
325	4196	4596	4996	5720	5721	6196	6596	6996	7720	7721
326	4197	4597	4997	5722	5723	6197	6597	6997	7722	7723
327	4198	4598	4998	5724	5725	6198	6598	6998	7724	7725
328	4199	4599	4999	5726	5727	6199	6599	6999	7726	7727
329	4200	4600	5000	5728	5729	6200	6600	7000	7728	7729
330	4201	4601	5001	5730	5731	6201	6601	7001	7730	7731
331	4202	4602	5002	5732	5733	6202	6602	7002	7732	7733
332	4203	4603	5003	5734	5735	6203	6603	7003	7734	7735
333	4204	4604	5004	5736	5737	6204	6604	7004	7736	7737
334	4205	4605	5005	5738	5739	6205	6605	7005	7738	7739
335	4206	4606	5006	5740	5741	6206	6606	7006	7740	7741
336	4207	4607	5007	5742	5743	6207	6607	7007	7742	7743
337	4208	4608	5008	5744	5745	6208	6608	7008	7744	7745
338	4209	4609	5009	5746	5747	6209	6609	7009	7746	7747
339	4210	4610	5010	5748	5749	6210	6610	7010	7748	7749
340	4211	4611	5011	5750	5751	6211	6611	7011	7750	7751
341	4212	4612	5012	5752	5753	6212	6612	7012	7752	7753
342	4213	4613	5013	5754	5755	6213	6613	7013	7754	7755
343	4214	4614	5014	5756	5757	6214	6614	7014	7756	7757
344	4215	4615	5015	5758	5759	6215	6615	7015	7758	7759
345	4216	4616	5016	5760	5761	6216	6616	7016	7760	7761
346	4217	4617	5017	5762	5763	6217	6617	7017	7762	7763
347	4218	4618	5018	5764	5765	6218	6618	7018	7764	7765
348	4219	4619	5019	5766	5767	6219	6619	7019	7766	7767
349	4220	4620	5020	5768	5769	6220	6620	7020	7768	7769
350	4221	4621	5021	5770	5771	6221	6621	7021	7770	7771

Positioning Data Number and Buffer Memory Address Conversion Table (continued)

Data No.	(X Axis)					(Y Axis)				
	Positioning Information	Positioning Speed	Dwell Time	Positioning Lower	Address Upper	Positioning Information	Positioning Speed	Dwell Time	Positioning Lower	Address Upper
351	4222	4622	5022	5772	5773	6222	6622	7022	7772	7773
352	4223	4623	5023	5774	5775	6223	6623	7023	7774	7775
353	4224	4624	5024	5776	5777	6224	6624	7024	7776	7777
354	4225	4625	5025	5778	5779	6225	6625	7025	7778	7779
355	4226	4626	5026	5780	5781	6226	6626	7026	7780	7781
356	4227	4627	5027	5782	5783	6227	6627	7027	7782	7783
357	4228	4628	5028	5784	5785	6228	6628	7028	7784	7785
358	4229	4629	5029	5786	5787	6229	6629	7029	7786	7787
359	4230	4630	5030	5788	5789	6230	6630	7030	7788	7789
360	4231	4631	5031	5790	5791	6231	6631	7031	7790	7791
361	4232	4632	5032	5792	5793	6232	6632	7032	7792	7793
362	4233	4633	5033	5794	5795	6233	6633	7033	7794	7795
363	4234	4634	5034	5796	5797	6234	6634	7034	7796	7797
364	4235	4635	5035	5798	5799	6235	6635	7035	7798	7799
365	4236	4636	5036	5800	5801	6236	6636	7036	7800	7801
366	4237	4637	5037	5802	5803	6237	6637	7037	7802	7803
367	4238	4638	5038	5804	5805	6238	6638	7038	7804	7805
368	4239	4639	5039	5806	5807	6239	6639	7039	7806	7807
369	4240	4640	5040	5808	5809	6240	6640	7040	7808	7809
370	4241	4641	5041	5810	5811	6241	6641	7041	7810	7811
371	4242	4642	5042	5812	5813	6242	6642	7042	7812	7813
372	4243	4643	5043	5814	5815	6243	6643	7043	7814	7815
373	4244	4644	5044	5816	5817	6244	6644	7044	7816	7817
374	4245	4645	5045	5818	5819	6245	6645	7045	7818	7819
375	4246	4646	5046	5820	5821	6246	6646	7046	7820	7821
376	4247	4647	5047	5822	5823	6247	6647	7047	7822	7823
377	4248	4648	5048	5824	5825	6248	6648	7048	7824	7825
378	4249	4649	5049	5826	5827	6249	6649	7049	7826	7827
379	4250	4650	5050	5828	5829	6250	6650	7050	7828	7829
380	4251	4651	5051	5830	5831	6251	6651	7051	7830	7831
381	4252	4652	5052	5832	5833	6252	6652	7052	7832	7833
382	4253	4653	5053	5834	5835	6253	6653	7053	7834	7835
383	4254	4654	5054	5836	5837	6254	6654	7054	7836	7837
384	4255	4655	5055	5838	5839	6255	6655	7055	7838	7839
385	4256	4656	5056	5840	5841	6256	6656	7056	7840	7841
386	4257	4657	5057	5842	5843	6257	6657	7057	7842	7843
387	4258	4658	5058	5844	5845	6258	6658	7058	7844	7845
388	4259	4659	5059	5846	5847	6259	6659	7059	7846	7847
389	4260	4660	5060	5848	5849	6260	6660	7060	7848	7849
390	4261	4661	5061	5850	5851	6261	6661	7061	7850	7851
391	4262	4662	5062	5852	5853	6262	6662	7062	7852	7853
392	4263	4663	5063	5854	5855	6263	6663	7063	7854	7855
393	4264	4664	5064	5856	5857	6264	6664	7064	7856	7857
394	4265	4665	5065	5858	5859	6265	6665	7065	7858	7859
395	4266	4666	5066	5860	5861	6266	6666	7066	7860	7861
396	4267	4667	5067	5862	5863	6267	6667	7067	7862	7863
397	4268	4668	5068	5864	5865	6268	6668	7068	7864	7865
398	4269	4669	5069	5866	5867	6269	6669	7069	7866	7867
399	4270	4670	5070	5868	5869	6270	6670	7070	7868	7869
400	4271	4671	5071	5870	5871	6271	6671	7071	7870	7871

**Appendix 6 Transportation Precautions**

When transporting lithium batteries, make sure to treat them based on the transport regulations.

**Appendix 6 .1 Controlled**

The batteries for Memory card is classified as follows:

Product name	Model	Product supply status	Memory card
Packed with lithium coin battery (BR2325)	A6BAT	Packed with lithium coin battery (BR2325)	Non-dangerous goods

**Appendix 6 .2 Transport guidelines**

Comply with IATA Dangerous Goods Regulations, IMDG code and the local transport regulations when transporting products after unpacking or repacking, while Mitsubishi ships products with packages to comply with the transport regulations. Also, contact the transporters.



# WARRANTY

Please confirm the following product warranty details before starting use.

## 1. Gratis Warranty Term and Gratis Warranty Range

If any faults or defects (hereinafter "Failure") found to be the responsibility of Mitsubishi occurs during use of the product within the gratis warranty term, the product shall be repaired at no cost via the dealer or Mitsubishi Service Company. Note that if repairs are required at a site overseas, on a detached island or remote place, expenses to dispatch an engineer shall be charged for.

### [Gratis Warranty Term]

The gratis warranty term of the product shall be for one year after the date of purchase or delivery to a designated place.

Note that after manufacture and shipment from Mitsubishi, the maximum distribution period shall be six (6) months, and the longest gratis warranty term after manufacturing shall be eighteen (18) months. The gratis warranty term of repair parts shall not exceed the gratis warranty term before repairs.

### [Gratis Warranty Range]

- (1) The range shall be limited to normal use within the usage state, usage methods and usage environment, etc., which follow the conditions and precautions, etc., given in the instruction manual, user's manual and caution labels on the product.
- (2) Even within the gratis warranty term, repairs shall be charged for in the following cases.
  1. Failure occurring from inappropriate storage or handling, carelessness or negligence by the user. Failure caused by the user's hardware or software design.
  2. Failure caused by unapproved modifications, etc., to the product by the user.
  3. When the Mitsubishi product is assembled into a user's device, Failure that could have been avoided if functions or structures, judged as necessary in the legal safety measures the user's device is subject to or as necessary by industry standards, had been provided.
  4. Failure that could have been avoided if consumable parts (battery, backlight, fuse, etc.) designated in the instruction manual had been correctly serviced or replaced.
  5. Failure caused by external irresistible forces such as fires or abnormal voltages, and Failure caused by force majeure such as earthquakes, lightning, wind and water damage.
  6. Failure caused by reasons unpredictable by scientific technology standards at time of shipment from Mitsubishi.
  7. Any other failure found not to be the responsibility of Mitsubishi or the user.

## 2. Onerous repair term after discontinuation of production

- (1) Mitsubishi shall accept onerous product repairs for seven (7) years after production of the product is discontinued. Discontinuation of production shall be notified with Mitsubishi Technical Bulletins, etc.
- (2) Product supply (including repair parts) is not possible after production is discontinued.

## 3. Overseas service

Overseas, repairs shall be accepted by Mitsubishi's local overseas FA Center. Note that the repair conditions at each FA Center may differ.

## 4. Exclusion of chance loss and secondary loss from warranty liability

Regardless of the gratis warranty term, Mitsubishi shall not be liable for compensation to damages caused by any cause found not to be the responsibility of Mitsubishi, chance losses, lost profits incurred to the user by Failures of Mitsubishi products, damages and secondary damages caused from special reasons regardless of Mitsubishi's expectations, compensation for accidents, and compensation for damages to products other than Mitsubishi products and other duties.

## 5. Changes in product specifications

The specifications given in the catalogs, manuals or technical documents are subject to change without prior notice.

## 6. Product application

- (1) In using the Mitsubishi MELSEC programmable logic controller, the usage conditions shall be that the application will not lead to a major accident even if any problem or fault should occur in the programmable logic controller device, and that backup and fail-safe functions are systematically provided outside of the device for any problem or fault.
- (2) The Mitsubishi general-purpose programmable logic controller has been designed and manufactured for applications in general industries, etc. Thus, applications in which the public could be affected such as in nuclear power plants and other power plants operated by respective power companies, and applications in which a special quality assurance system is required, such as for Railway companies or National Defense purposes shall be excluded from the programmable logic controller applications.

Note that even with these applications, if the user approves that the application is to be limited and a special quality is not required, application shall be possible.

When considering use in aircraft, medical applications, railways, incineration and fuel devices, manned transport devices, equipment for recreation and amusement, and safety devices, in which human life or assets could be greatly affected and for which a particularly high reliability is required in terms of safety and control system, please consult with Mitsubishi and discuss the required specifications.

# Positioning Module Type AD71(S1/S2/S7)/A1SD71-S2(S7)

## User's Manual

MODEL	AD71,A1SD71-U-E
MODEL CODE	13JE98
IB(NA)-66563-B(0310)MEE	

 **MITSUBISHI ELECTRIC CORPORATION**

HEAD OFFICE : 1-8-12, OFFICE TOWER Z 14F HARUMI CHUO-KU 104-6212,JAPAN  
NAGOYA WORKS : 1-14 , YADA-MINAMI 5-CHOME , HIGASHI-KU, NAGOYA , JAPAN

When exported from Japan, this manual does not require application to the Ministry of Economy, Trade and Industry for service transaction permission.

Specifications subject to change without notice.